



國立陽明交通大學

NATIONAL YANG MING CHIAO TUNG UNIVERSITY

國立陽明交通大學

電腦輔助工程分析

ANSYS WORKBENCH

國立陽明交通大學 生物醫學工程系
林峻立 特聘教授



2026/02



- 00** Class Introduction
- 01** Concept Introduction
- 02** Workbench
- 03** Design Modeler
- 04** Static Structural Analysis
- 05** Advanced Analysis

00

Class Introduction

課程介紹





CAE/FEM Applications

■ 新型骨鬆用椎籠(Cage)設計與分析

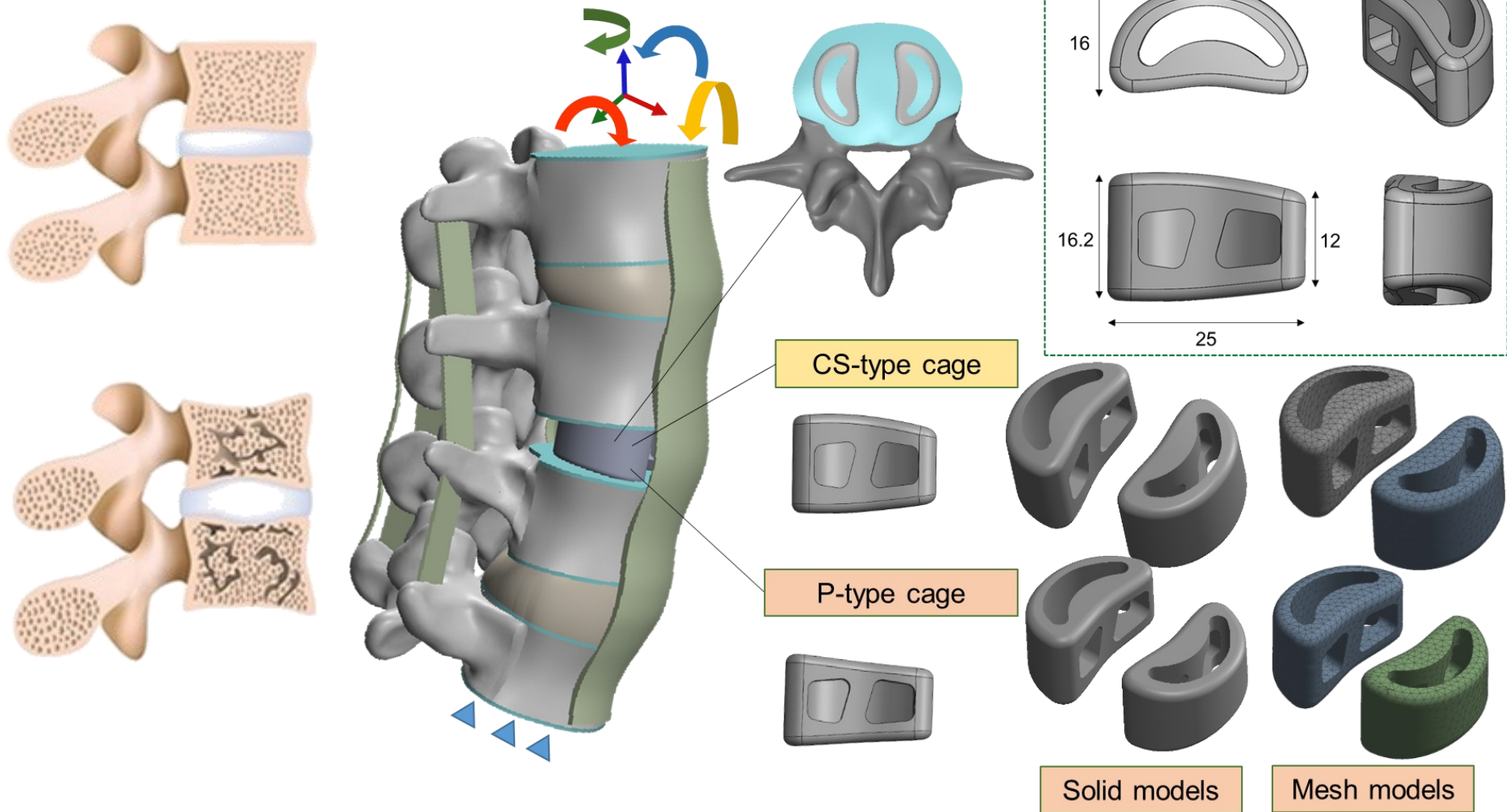

■ 新型骨鬆用椎籠(Cage)設計與分析

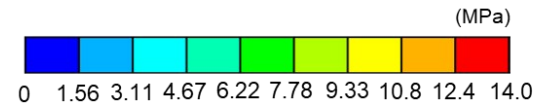
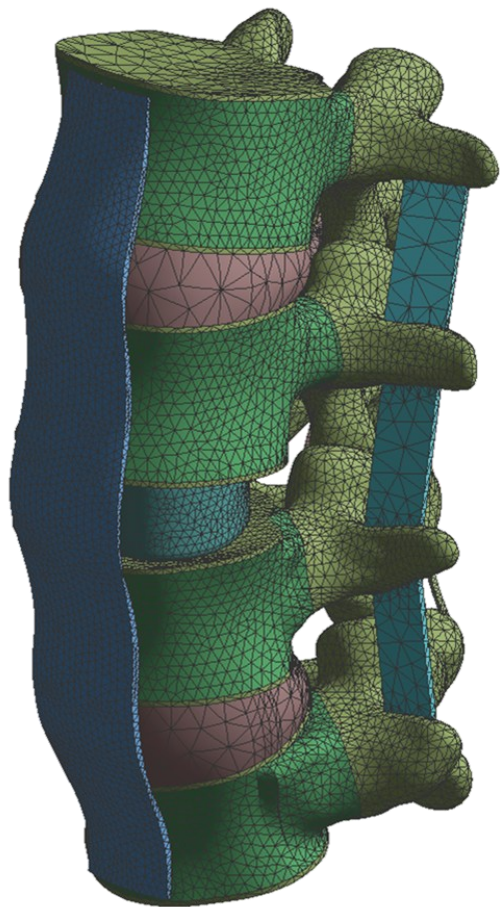

		Flexion	Extension	Bending	Rotation
L3-Inferior					
CS-type		3.82 MPa	0.79 MPa	7.28 MPa	3.15 MPa
P-type		9.31 MPa	3.02 MPa	9.63 MPa	12.8 MPa
L4-superior					
CS-type		6.86 MPa	0.83 MPa	6.50 MPa	4.60 MPa
P-type		12.0 MPa	3.39 MPa	10.2 MPa	6.67 MPa

■ 新型骨鬆用椎籠(Cage)設計與分析



International Journal of Bioprinting

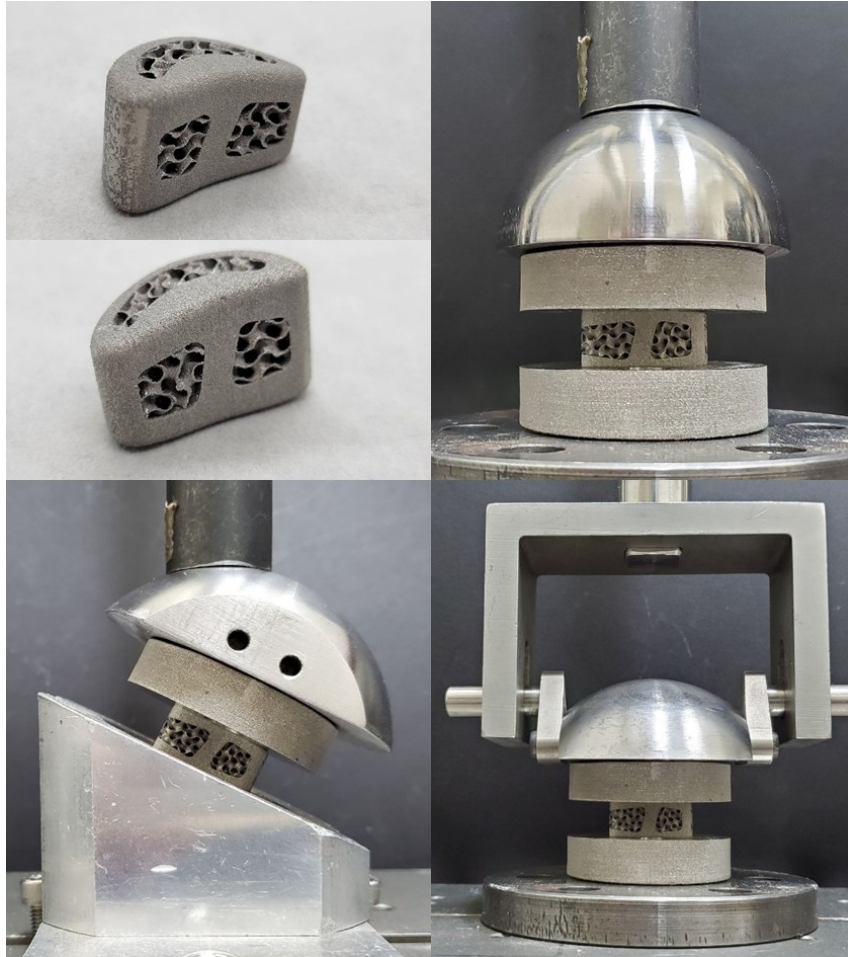

RESEARCH ARTICLE

Biomechanical evaluation of an osteoporotic anatomical 3D printed posterior lumbar interbody fusion cage with internal lattice design based on weighted topology optimization

Shao-Fu Huang^{1,2}, Chun-Ming Chang³, Chi-Yang Liao^{1,4,5}, Yi-Ting Chan¹, Zi-Yi Li¹, Chun-Li Lin^{1,2*}

¹Department of Biomedical Engineering, National Yang Ming Chiao Tung University, Hsinchu, Taiwan

²Innovation and Translation Center of Medical Device, Department of Biomedical Engineering, National Yang Ming Chiao Tung University, Hsinchu, Taiwan

³National Applied Research Laboratories, Taiwan Instrument Research Institute, Hsinchu, Taiwan

⁴Department of Orthopedics, Tri-Service General Hospital Songshan Branch, National Defense Medical Center, Taipei, Taiwan

⁵Department of Surgery, Tri-Service General Hospital Songshan Branch, National Defense Medical Center, Taipei, Taiwan

Abstract

In this study, we designed and manufactured a posterior lumbar interbody fusion cage for osteoporosis patients using 3D-printing. The cage structure conforms to the anatomical endplate's curved surface for stress transmission and internal lattice design for bone growth. Finite element (FE) analysis and weight topology optimization under different lumbar spine activity ratios were integrated to design the curved surface (CS-type) cage using the endplate surface morphology statistical results from the osteoporosis patients. The CS-type and plate (P-type) cage biomechanical behaviors under different daily activities were compared by performing non-linear FE analysis. A gyroid lattice with 0.25 spiral wall thickness was then designed in the internal cavity of the CS-type cage. The CS-cage was manufactured using metal 3D printing to conduct *in vitro* biomechanical tests. The FE analysis result showed that the maximum stress values at the inferior L3 and superior L4 endplates under all daily activities for the P-type cage implantation model were all higher than those for the CS-type cage. Fracture might occur in the P-type cage because the maximum stresses found in the endplates exceeded its ultimate strength (about 10 MPa) under flexion, torsion and bending loads. The yield load and stiffness of our designed CS-type cage

*Corresponding author:
Chun-Li Lin
(clin2@ym.edu.tw)

Citation: Huang S, Chang C, Liao C, *et al.*, 2023, Biomechanical evaluation of an osteoporotic anatomical 3D printed posterior lumbar interbody fusion cage with internal lattice design based on weighted topology optimization. *Int J Bioprint*, 9(3): 0212. <https://doi.org/10.18063/ijb.v9i3.0212>

Received: September 27, 2022

Accepted: November 27, 2022

Published Online: XXX

Copyright: © 2023 Author(s).
This is an Open Access article

CAE/FEM Applications

■ 下顎骨植入物最佳化與力學分析

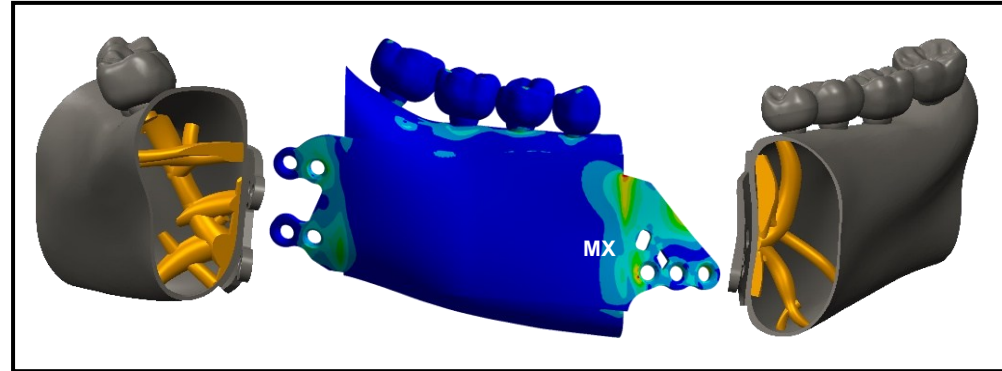
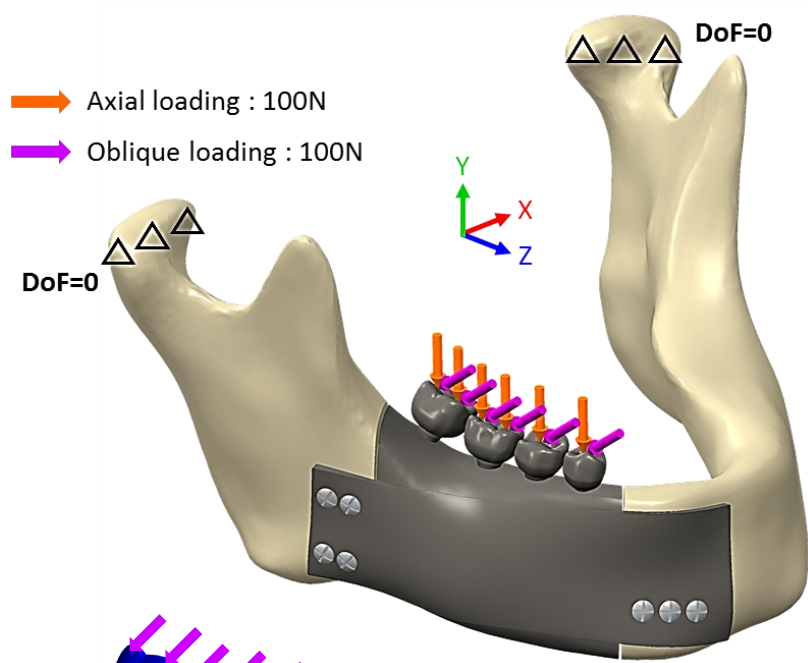

結構最佳化與力學分析結果



金屬3D列印利用分析開發出之新型植入物

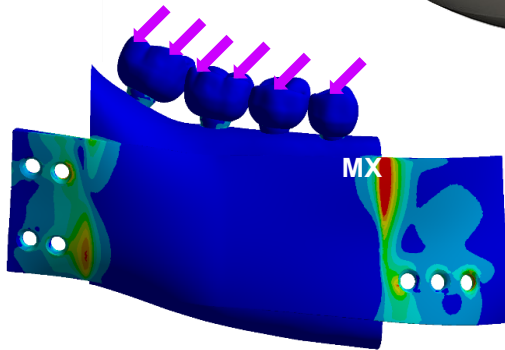

結構固定處設計分析



OM model

WOS model

■ 下顎骨植入物最佳化與力學分析

Fracture patterns

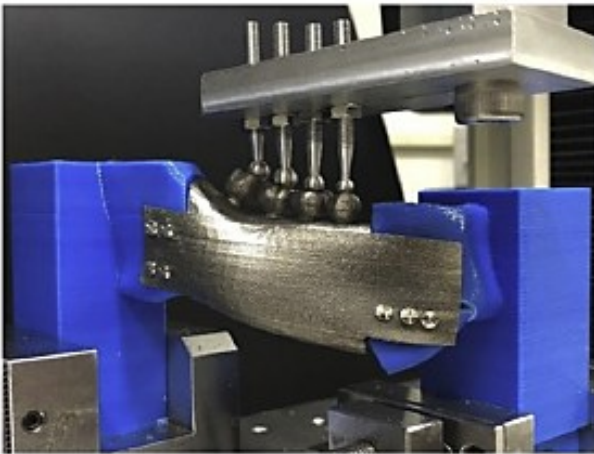

OM model

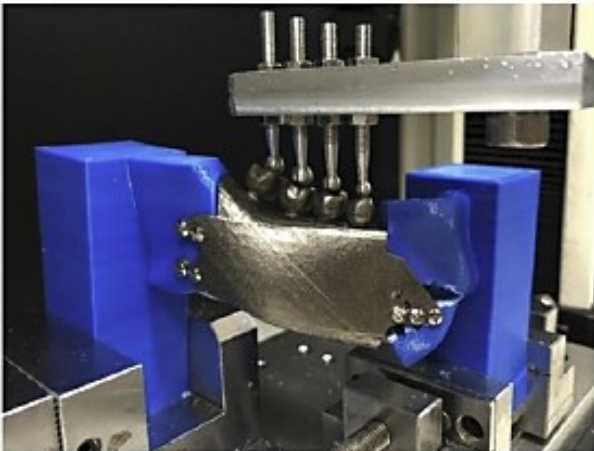

WBOS model

journal of the mechanical behavior of biomedical materials 105 (2020) 103700



Contents lists available at ScienceDirect

Journal of the Mechanical Behavior of Biomedical Materials

journal homepage: <http://www.elsevier.com/locate/jmbbm>



Design of a patient-specific mandible reconstruction implant with dental prosthesis for metal 3D printing using integrated weighted topology optimization and finite element analysis

Chia-Hsuan Li^a, Cheng-Hsien Wu^b, Chun-Li Lin^{a,*}

^a Department of Biomedical Engineering, National Yang-Ming University, 2 No.155, Sec.2, Linong Street, Taipei, 112, Taiwan

^b Oral & Maxillofacial Surgery, Taipei Veterans General Hospital, School of Dentistry, National Yang-Ming University, 2 No.155, Sec.2, Linong Street, Taipei, 112, Taiwan

ARTICLE INFO

Keywords:

Patient-specific implant
Mandibular reconstruction
Dental prosthesis
3D printing
Topology optimization
Finite element analysis

ABSTRACT

The aim of this study was used a weighted topology optimization method to design a patient-specific mandibular implant for reconstruction and restoration of appearance in patients with severe mandibular defects. A finite element (FE) model was constructed and the defect region was defined from the unilateral first premolar to the second molar. The reconstruction implant included main body, fixation wing and dental prosthesis. Standard topology optimization was performed using stress constraint to identify optimal fixation wing structure (denoted as WOS) with solid core main body. Two independent optimal main body with internal beam supporting structures defined as WOSA and WOSO optimized from the WOS model under axial and oblique conditions were then obtained, respectively. Final optimal model (WBOS) was generated using a weighted topology optimization that considered 60% and 40% contributions of WOSA and WOSO models, respectively. The WBOS model was fabricated using metal 3D printing and fixed on the resting acrylonitrile butadiene styrene (ABS) bone to perform fracture testing. Stress concentration were found in the upper area connected to the main body of the mesial wing and corresponding maximum values under axial/oblique loads were reduced from 778/925 MPa of the WOS model to 764/720 MPa of the WBOS model. The reduction in percentage variations of weight between original (91.1 g) and final optimal (24.5 g) models was 73.14% for fabricated 3D printing models. The WBOS model also exhibited a higher resistant force (2163 N) when compared with the original model (1678 N). This study developed a design strategy with weighted topology optimization and fabrication for producing patient-specific implants using metal 3D printing. The obtained reconstruction implant can provide good biomechanical performance and recovery of appearance for oral rehabilitation.

1. Introduction

The main objective of reconstruction for severe mandibular defects is to restore functional components of the facial skeleton and contribute to individual facial identity, mastication, speech, swallowing, and appearance (Dostal et al., 2010). While free flap transfer is the gold

of the mandible, and to restore facial contours and masticatory function (Pinheiro and Alves, 2015; Stoor et al., 2017; Yusa et al., 2017; Lee et al., 2018; Cheng et al., 2019). These considerations are particularly important for patients who need complex postoperative dental prostheses that ensure quality of life.

Compared with maxillary facial reconstruction and dental prostheses

■ 股骨大範圍缺損力學分析



Article

Patient-Specific 3-Dimensional Printing Titanium Implant Biomechanical Evaluation for Complex Distal Femoral Open Fracture Reconstruction with Segmental Large Bone Defect: A Nonlinear Finite Element Analysis

Kin Weng Wong ^{1,2}, Chung Da Wu ², Chi-Sheng Chien ^{2,3}, Cheng-Wei Lee ⁴, Tai-Hua Yang ^{1,5,6,*} and Chun-Li Lin ^{4,*}

¹ Department of Biomedical Engineering, National Cheng Kung University, Tainan 601, Taiwan; P88071046@ncku.edu.tw

² Department of Orthopedic Surgery, Chi-mei Medical Center, Tainan 601, Taiwan; wcd@mail.chimei.org.tw (C.D.W.); cschien@stust.edu.tw (C.-S.C.)

³ Department of Electrical Engineering, Southern Taiwan University and Technology, Tainan 112, Taiwan

⁴ Department of Biomedical Engineering, National Yang-Ming University, Taipei 11221, Taiwan; justinlee102185@ym.edu.tw

⁵ Department of Orthopedic Surgery, National Cheng Kung University Hospital, Tainan 601, Taiwan

⁶ Medical Device Innovation Center, College of Medicine, National Cheng Kung University, Tainan 601, Taiwan

* Correspondence: yangtaihua@mail.ncku.edu.tw (T.-H.Y.); cllin2@ym.edu.tw (C.-L.L.)

Received: 14 May 2020; Accepted: 10 June 2020; Published: 14 June 2020



Abstract: This study proposes a novel titanium 3D printing patient-specific implant: a lightweight structure with enough biomechanical strength for a distal femur fracture with segmental large defect using nonlinear finite element (FE) analysis. CT scanning images were processed to identify the size and shape of a large bone defect in the right distal femur of a young patient. A novel titanium implant was designed with a proximal cylinder tube for increasing mechanical stability, proximal/distal shells for increasing bone ingrowth contact areas, and lattice mesh at the outer surface to provide space for morselized cancellous bone grafting. The implant was fixed by transverse screws at the proximal/distal host bone. A pre-contoured locking plate was applied at the lateral site to secure the whole construct. A FE model with nonlinear contact element implant-bone interfaces was constructed to perform simulations for three clinical stages under single leg standing load conditions. The three stages were the initial postoperative period, fracture healing, and post fracture healing and locking plate removal. The results showed that the maximum implant von Mises stress reached 1318 MPa at the chamfer angle of the outer mesh structure, exceeding the titanium destruction value (1000 MPa).

01 **Concept Introduction**

CAE / FEM 基本概念介紹



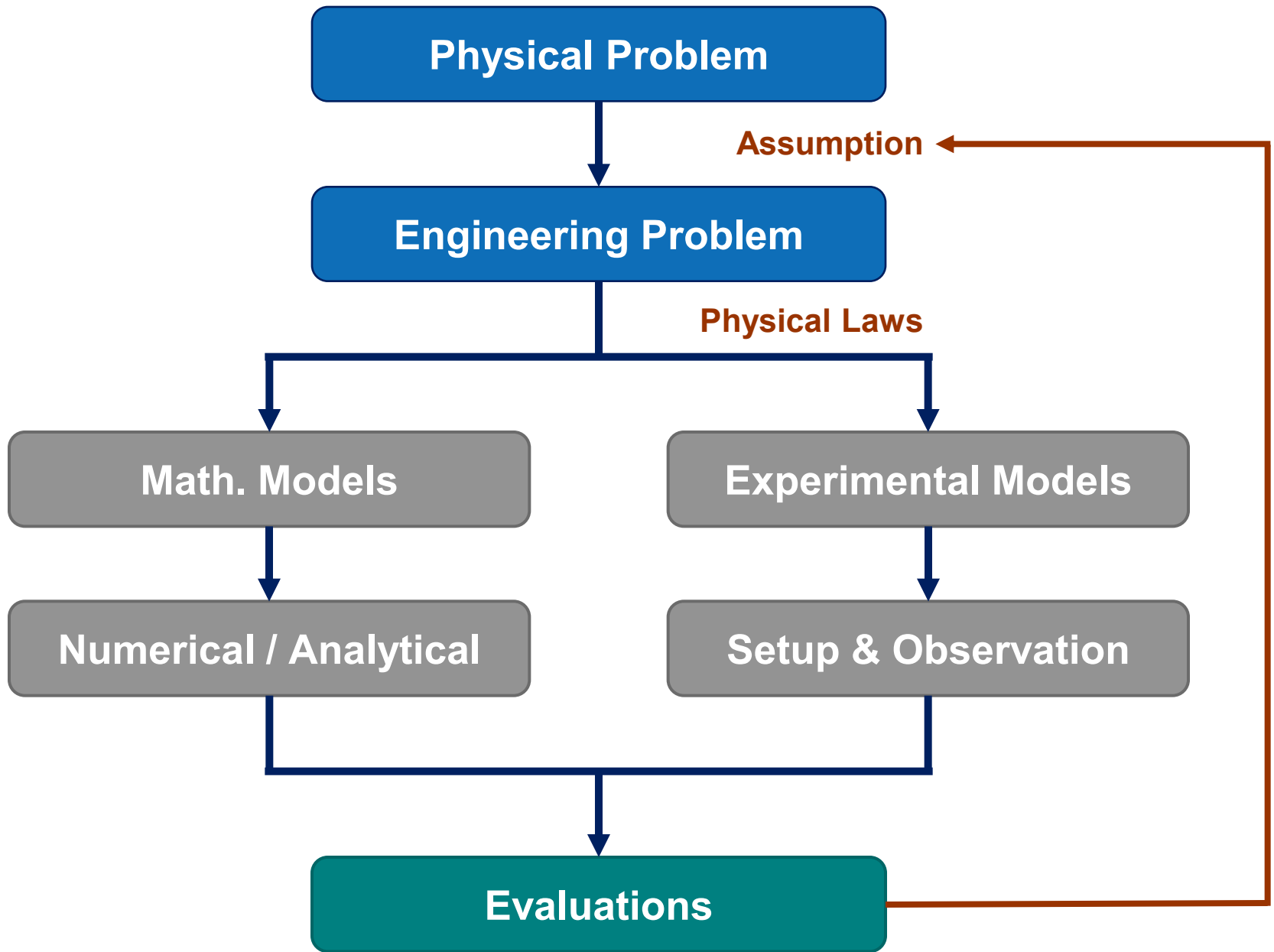



Fundamental Concepts in FEM

■ Analytical Method

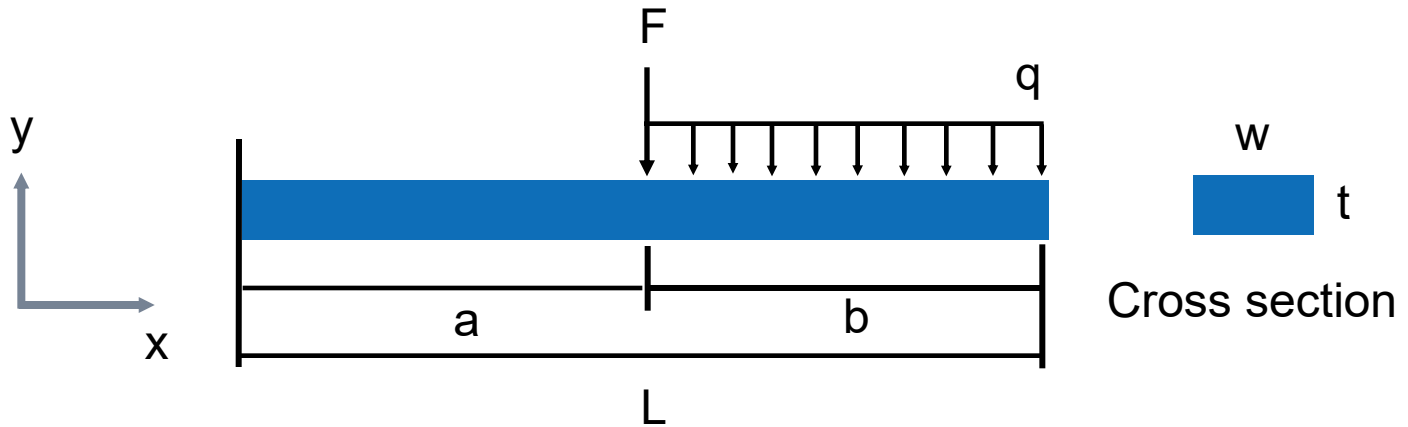

$$y = Fa^3(3L-a)/6EI + q(3L^4 - 4a^3L + a^4)/24EI$$

■ Numerical Method

■ FEM, BEM, FDM, etc.



Fundamental Concepts in FEM

- 實際的物理問題很難利用單一的微分方程式描述，更無法順利求其解析(analytical solution)解
- 有限元素法(Finite Element Method)的精神是將複雜的幾何外形的結構物體切割成許多簡單的幾何形狀稱之為**元素(element)**，元素與元素間以**節點(node)**相連
- 由於元素是簡單的幾何形狀，故可順利寫出元素的力平衡方程式並求得節點上之變位、應變及應力等
- 藉由內插法求得元素內任意點的變位、應變及應力等

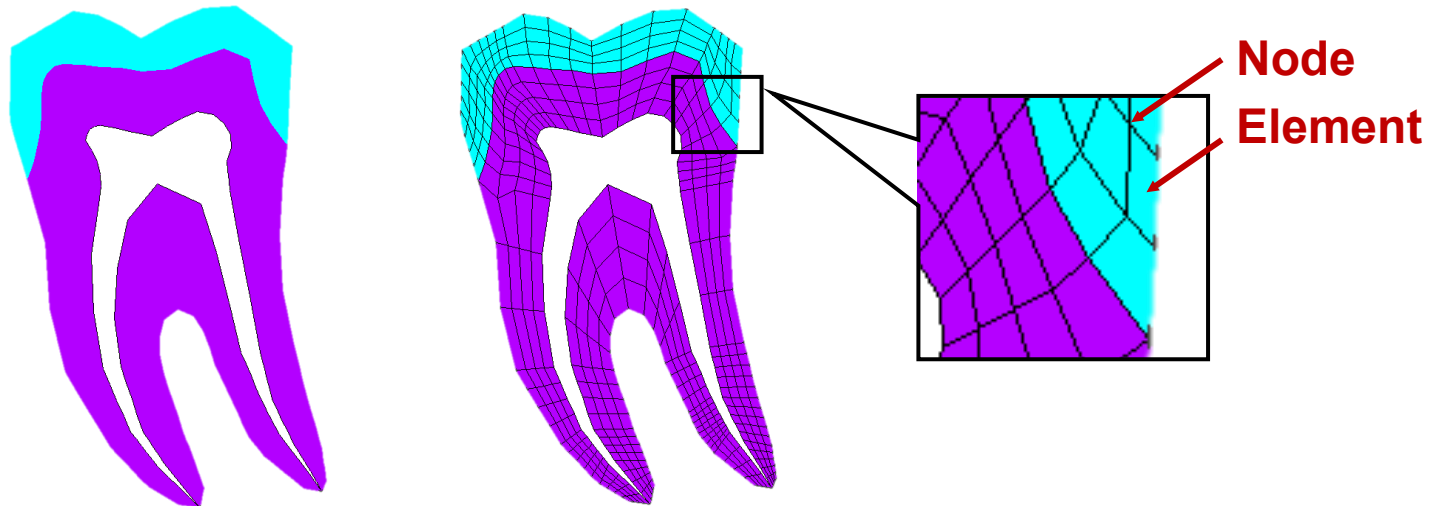



General Concept of CAE

- 所謂的**CAE**是指「**Computer-Aided Engineering**」之縮寫，中文普遍稱為「電腦輔助工程」或「電腦輔助工程分析」，大略來說，只要是**應用電腦來模擬分析實際物理問題**，均可將其稱為**CAE**
- **CAE**之分析類型很多，它包含了**結構應力分析**、**振動分析**、**流體分析**、**熱傳分析**、**電磁場分析**、**塑膠射出成型流動分析(模流分析)**、**鑄造流動分析**、**機構運動與動力學分析**等

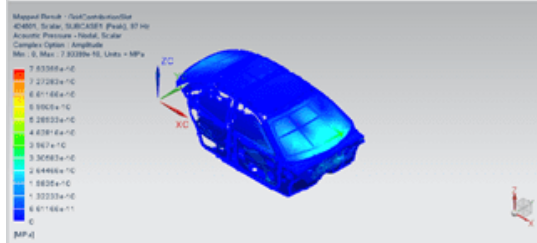
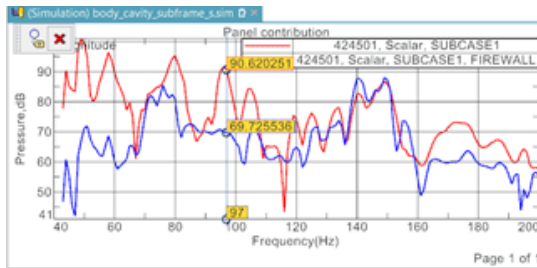

振動分析

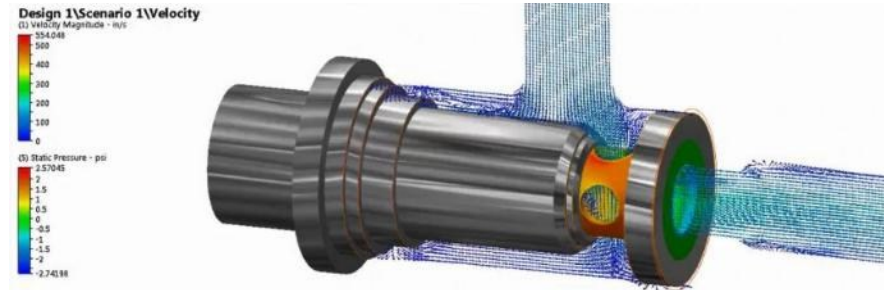

流體分析

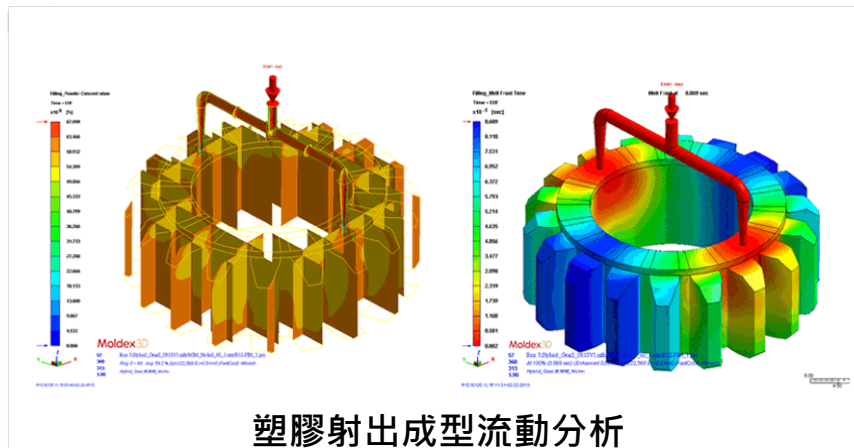

塑膠射出成型流動分析

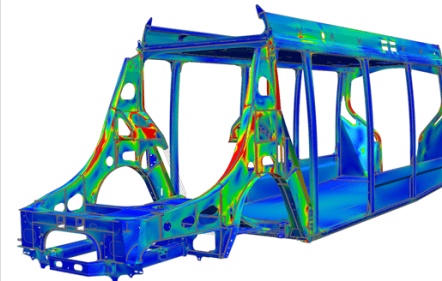

結構應力分析



General Concept of CAE

- 以固體力學為例，其CAE之主流數值方法為有限元素法(Finite Element Method, FEM)，亦可稱為有限元素分析(Finite Element Analysis, FEA)
- 其基本概念是把一個實際的連續性物體做離散化，分割成許多個元素(elements)與節點(nodes)，統稱為網格(mesh)，而每個元素均遵守力學基本理論模式。

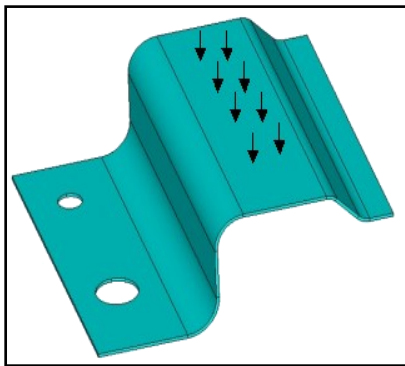

(a) 實際工程問題

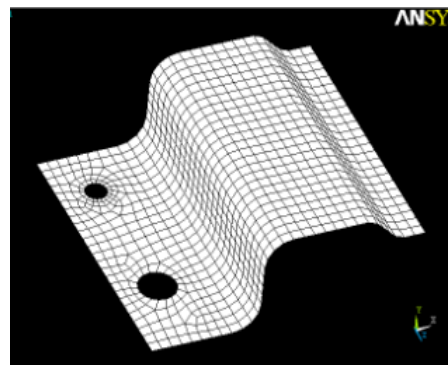

(b) 元素節點(網格)

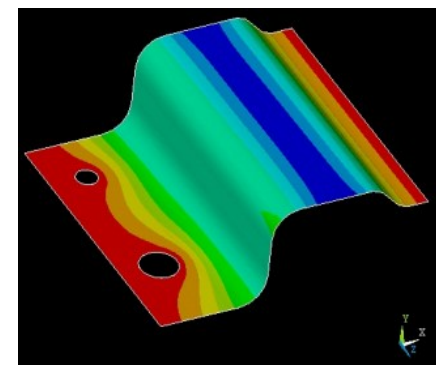

(c) 模擬之變形

3C/3R (CAD/CAM/CAE, RE/RP/RT)

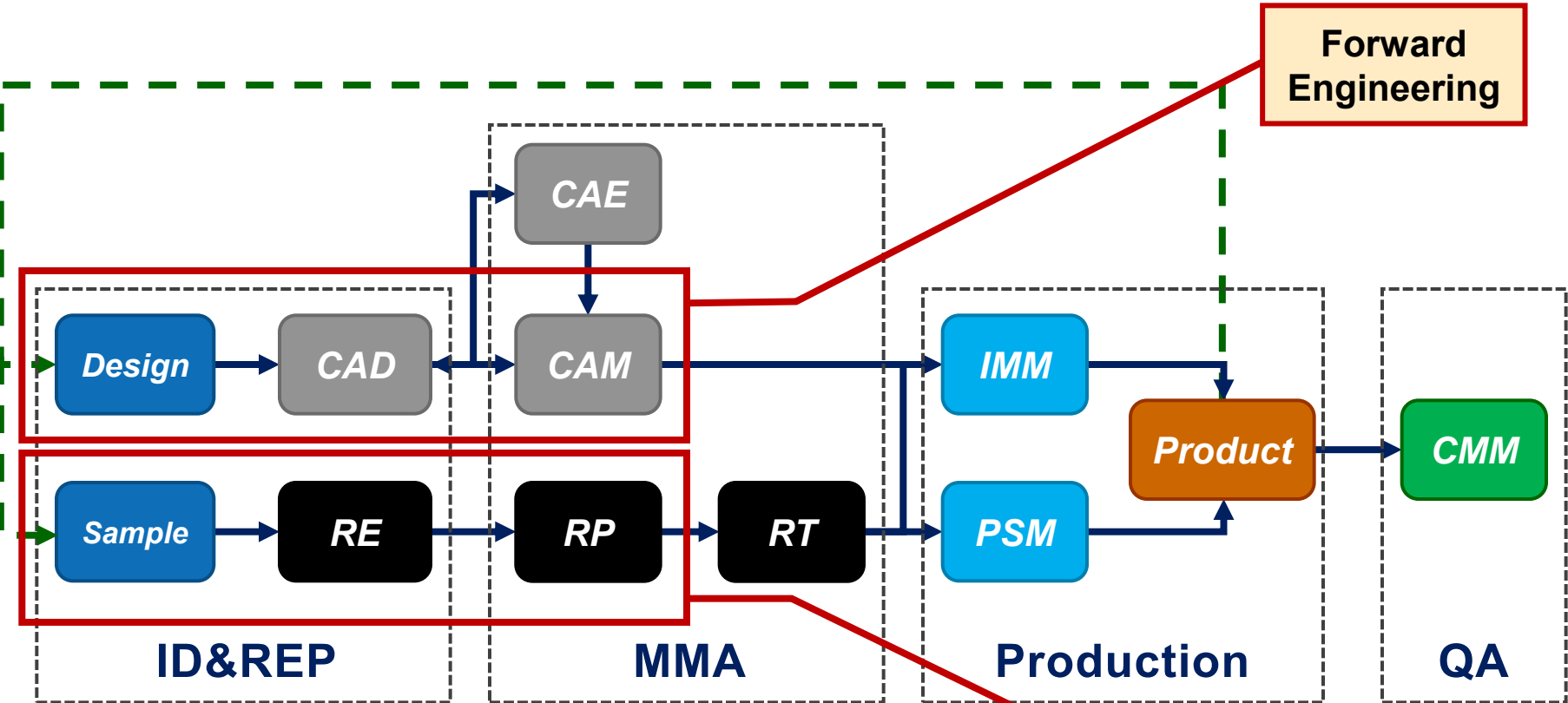

ID : Industrial design

MMA : Mold manufacturing & analysis

QA : Quality assurance

IMM : Injection moulding machine

PSM : Pressing/shearing machine



General Concept of CAE

- **CAE**和電腦輔助設計(Computer-Aided Design, **CAD**)與電腦輔助製造(Computer-Aided Manufacturing, **CAM**)同屬於電腦輔助之工具，近年來發展的**CAD/CAM/CAE**系統已成為工業界產品研發的利器，尤其成熟的**CAD/CAM**設計系統早已在許多台灣產業生根。
- 近年來**CAE**也逐漸受到國內產業界的重視。面對市場上激烈的競爭，各公司提升研發能力已是刻不容緩的事，而**CAE**正可成為提升研發能力的一大利器。

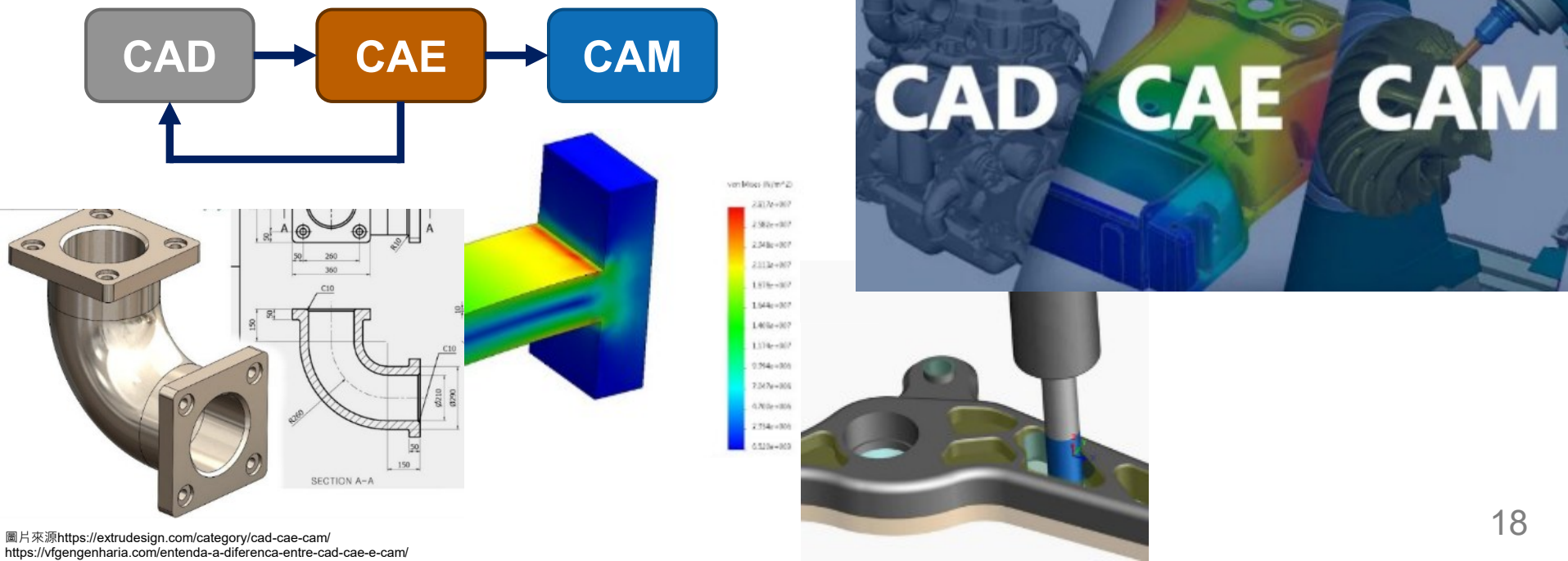

扳手之力學分析

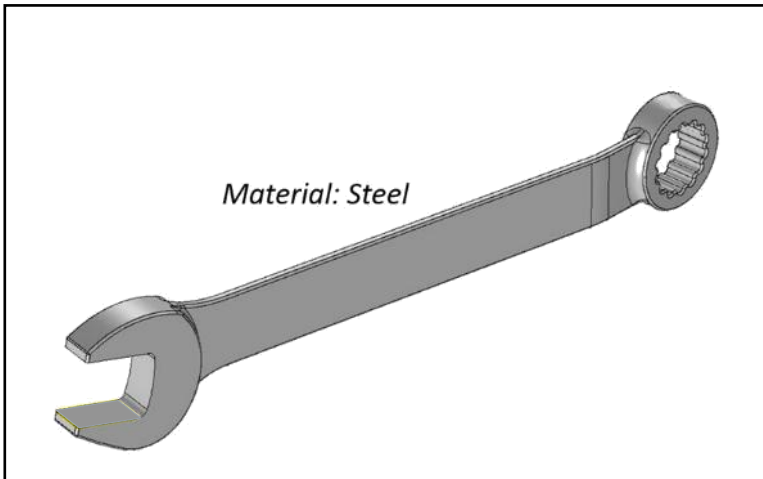

(a)幾何外形

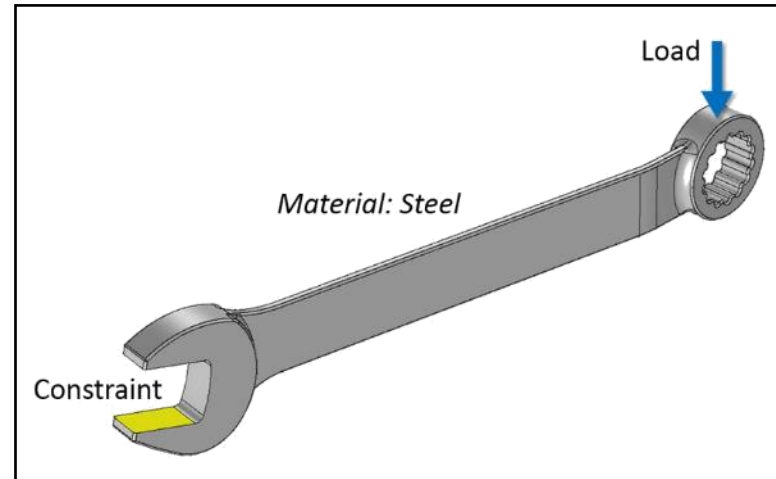

(b)邊界條件

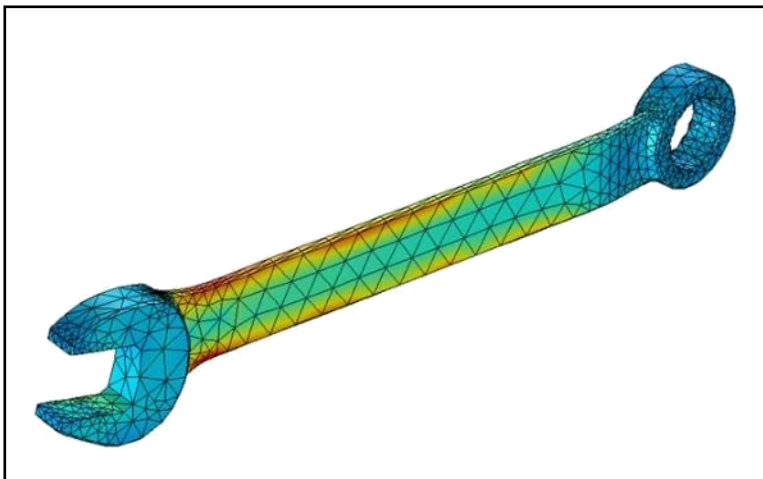

(c)網格處理

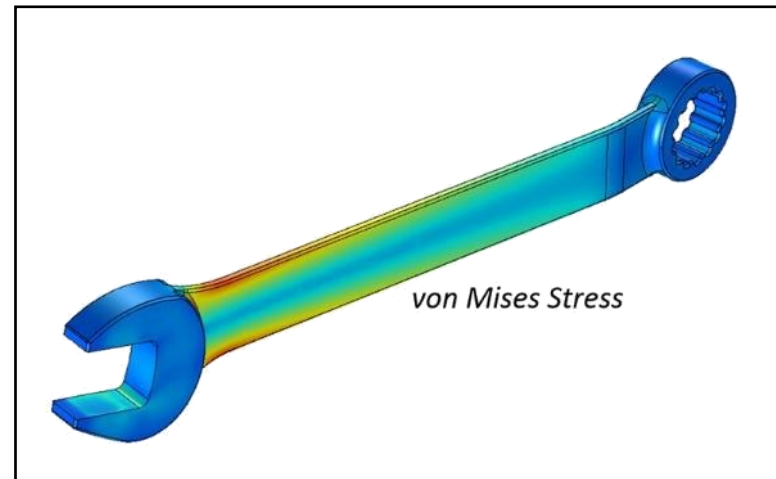

(d)應力結果

電腦散熱風扇葉片之模態分析

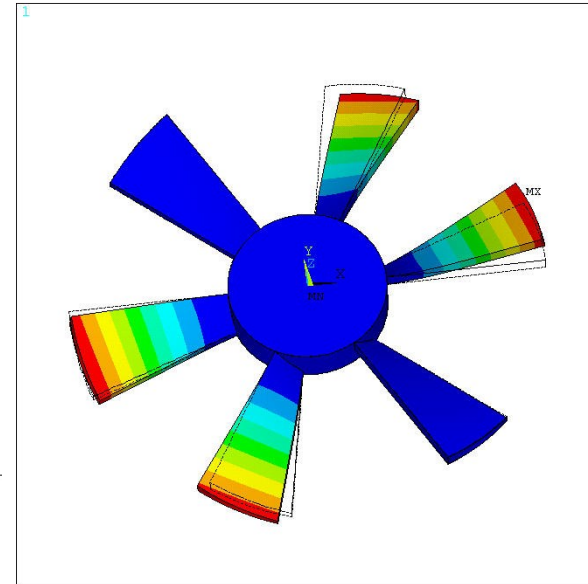
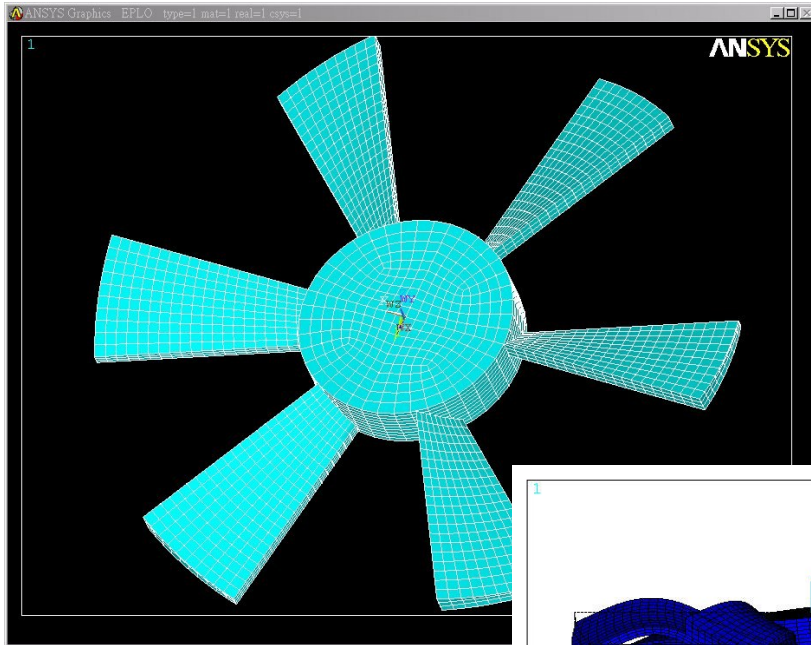

```

ANSYS 5.6.2
APR 19 2001
10:50:40
NODAL SOLUTION
STEP=1
SUB =7
FREQ=7.687
USUM      (AVG)
RSYS=0
PowerGraphics
EFACET=1
AVRES=Mat
DMX =6.297
SMN =.397E-04
SMX =6.297

```

Blue	.397E-04
Light Blue	.699745
Cyan	1.399
Green	2.099
Light Green	2.799
Yellow-Green	3.499
Yellow	4.198
Orange	4.898
Red-Orange	5.598
Red	6.297

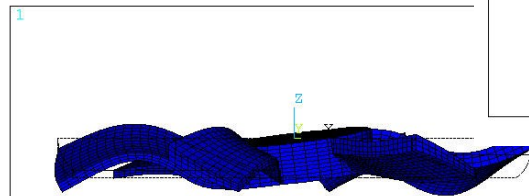

```

PowerGraphics
EFACET=1
AVRES=Mat
DMX =6.103

```

DSCA=.983199
YV =-1
*DIST=38.76
*XF =5.458
*YF =-9.383
*ZF =-5.233
Z-BUFFER

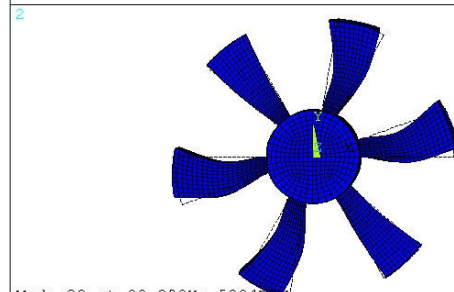

```

WIND=2
DSCA=.983199
ZV =1
DIST=65.522
XF =.766196
YF =-.613508
ZF =-5.376
Z-BUFFER
```

Mode 23 at 88.398Hz 5304REV

Biomechanical Analysis of Dental Implant

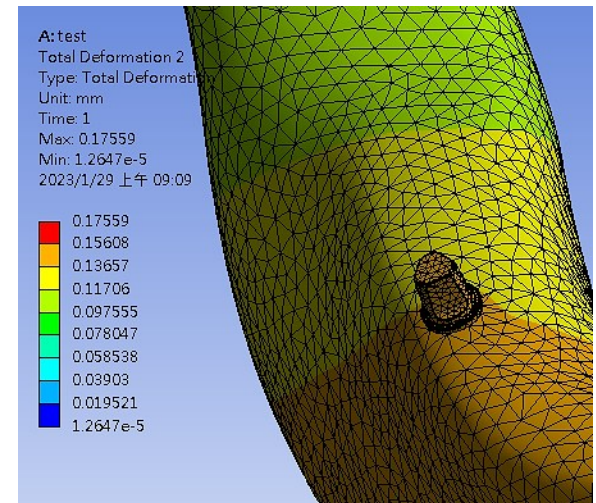
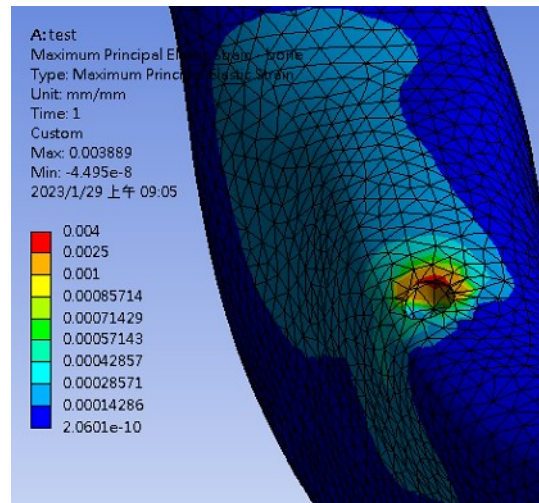
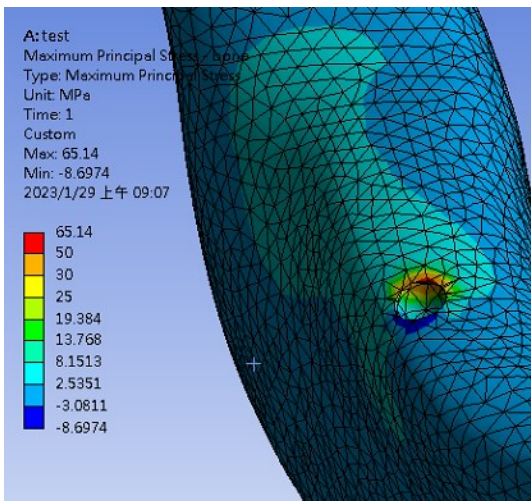
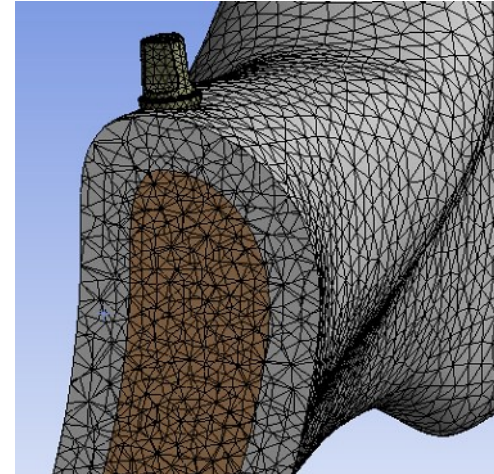
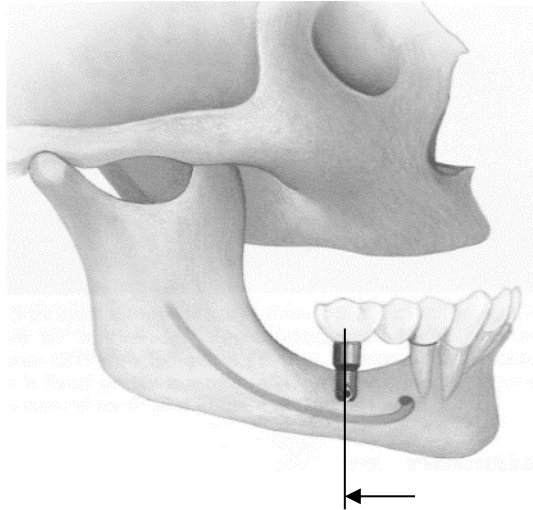

CAE Application in Spine Biomechanics

■ 術後鄰近節不穩定因素

- 脊椎融合術範圍(D.E)
- 脊椎減壓術範圍(C.D)

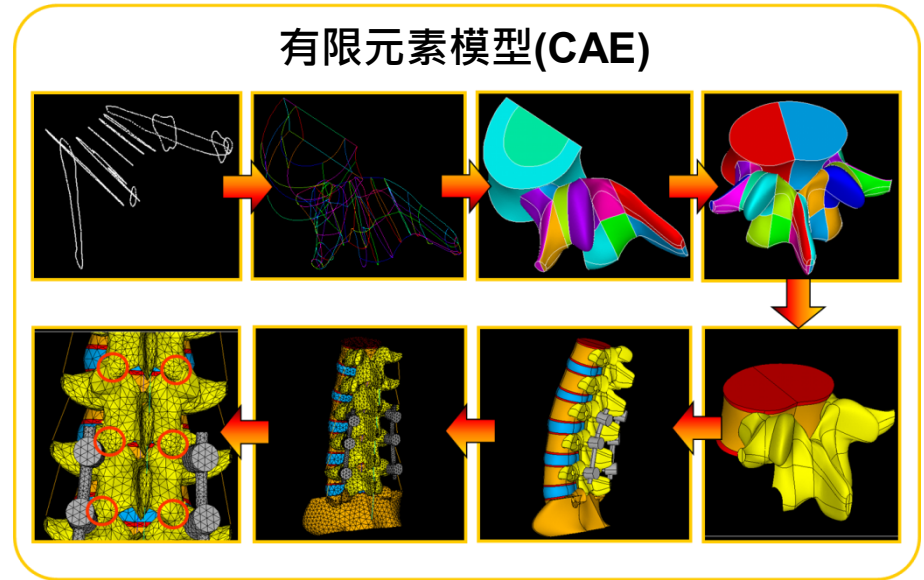
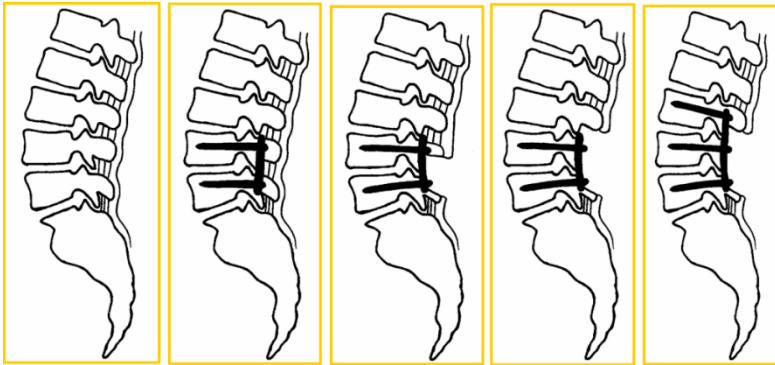

- 在前彎與側彎負載下，全減壓術移除後側張力帶機制導致鄰近節不穩定，尤其以上鄰近節應力集中最嚴重，建議盡量實行半減壓術

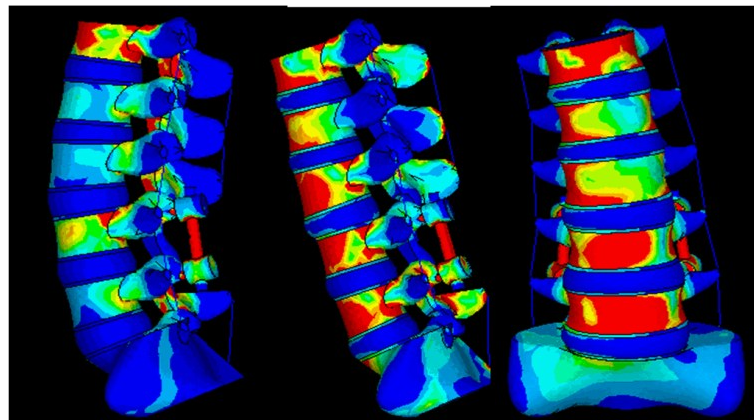
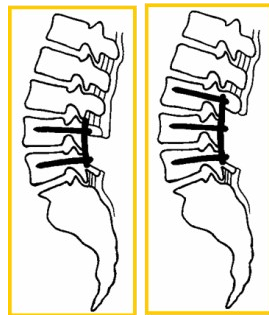

Computer Aided Analysis for Bone Remodeling

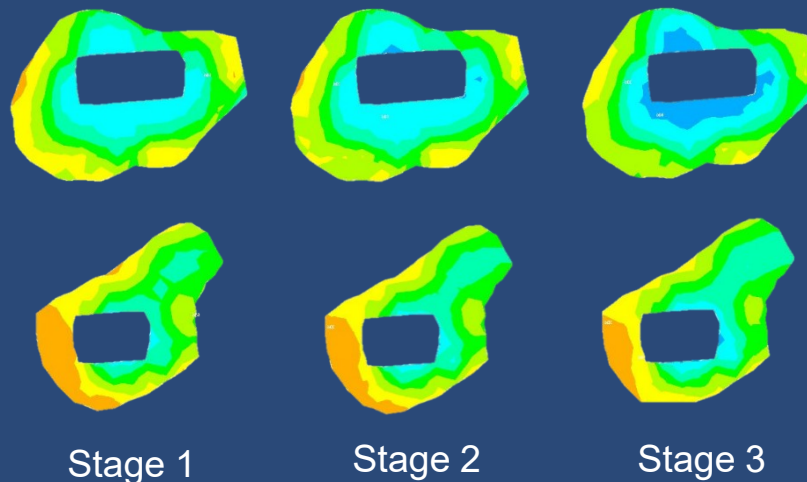
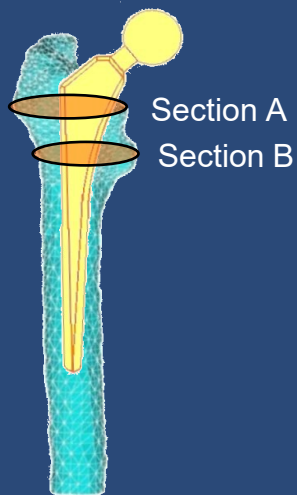
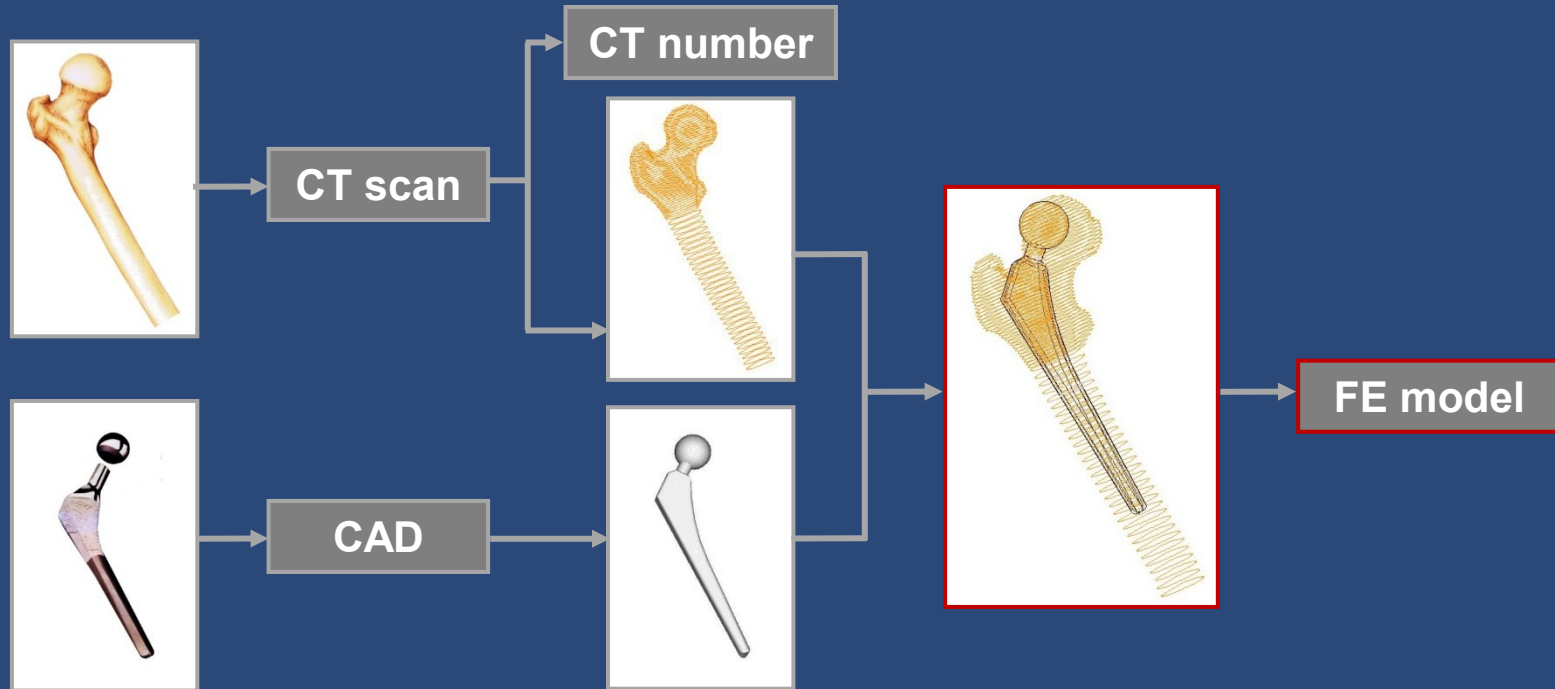

Density g/cm³

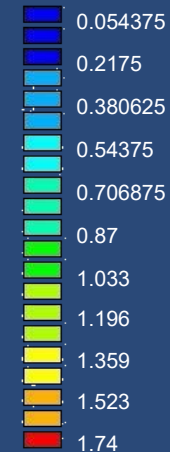

3D Modeling for Biological Structure

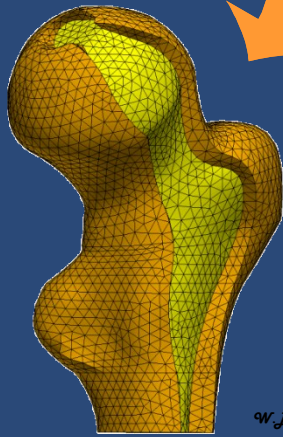
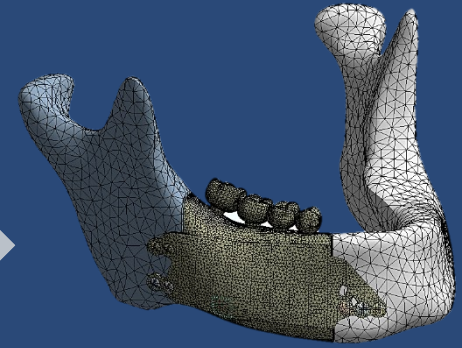
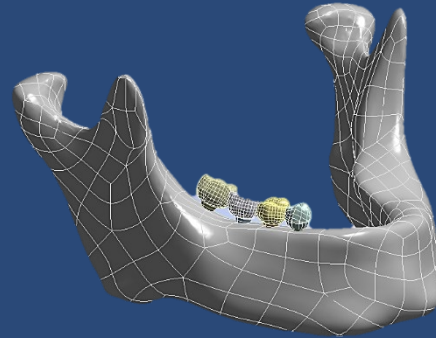
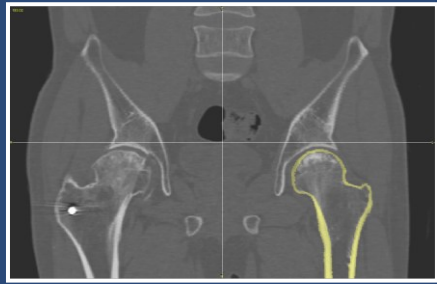

w.p.

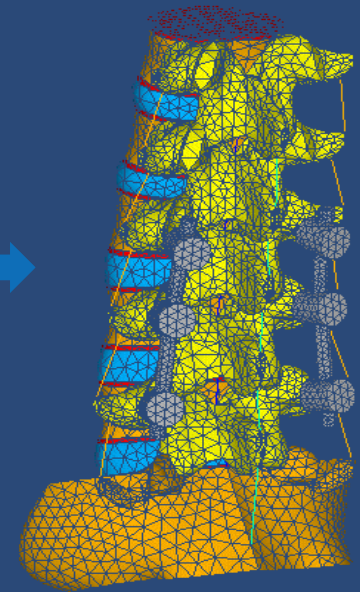
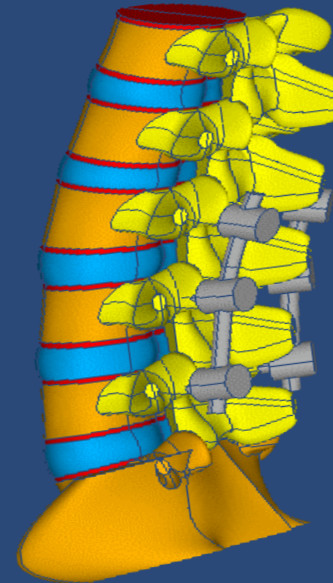
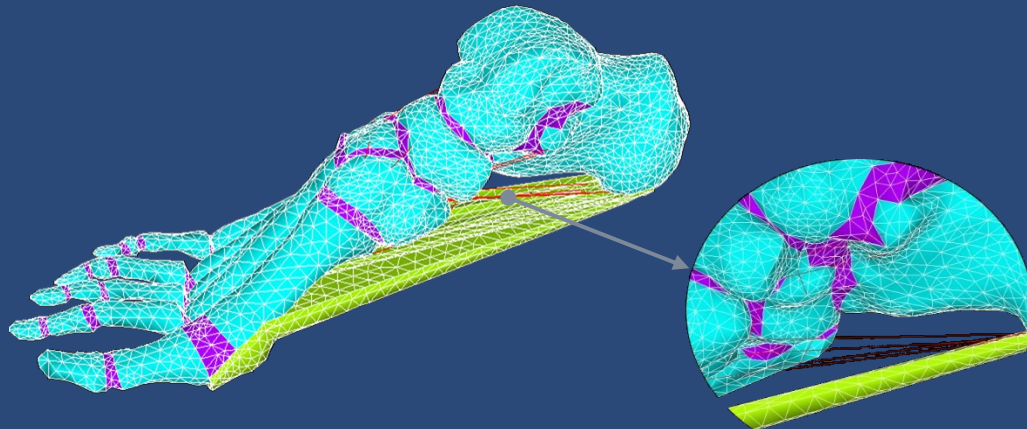

02

Workbench

ANSYS Workbench介紹





FE Package - ANSYS

- **ANSYS**是以**有限元素法**做為數值近似方法，分析功能包括固體力學、熱傳學、流體力學、電磁學及跨領域的耦合場(coupled field)分析等
- **ANSYS**為一套商業化之泛用型(**general-purpose**)有限元素分析軟體，包括：
 - **ANSYS-Classical(APDL)**
 - **ANSYS-Workbench**



本課程所應用之有限元素分析軟體，
並著重介紹**Mechanical**部分

A	
1	Static Structural
2	Engineering Data ✓
3	Geometry ?
4	Model ?
5	Setup ?
6	Solution ?
7	Results ?

Static Structural

B	
1	Topology Optimization
2	Engineering Data ✓
3	Geometry ?
4	Model ?
5	Setup ?
6	Solution ?
7	Results ?

Topology Optimization

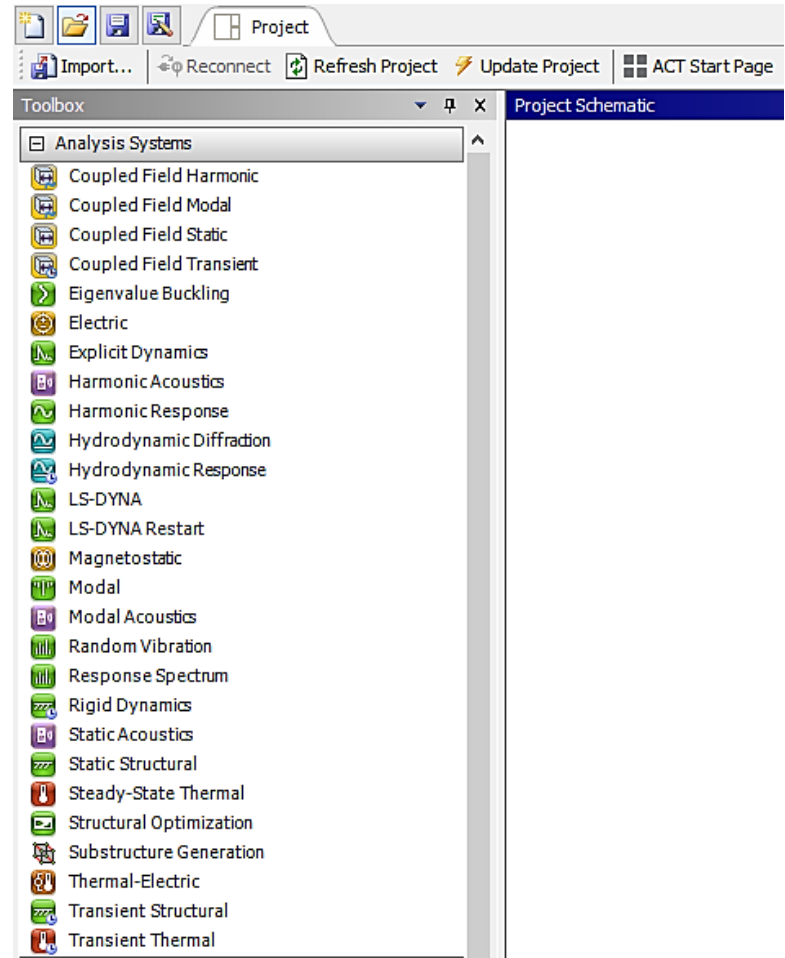

ANSYS Classical(APDL) / Workbench

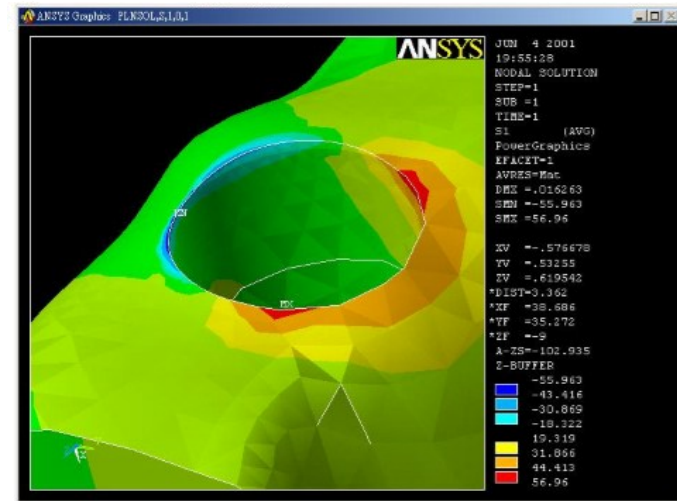
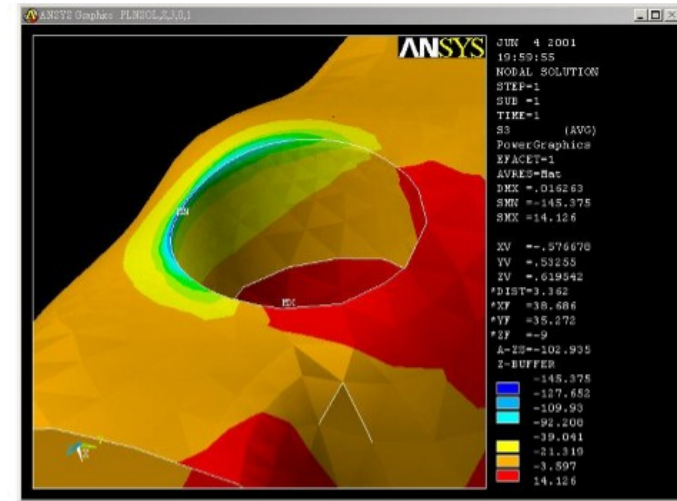
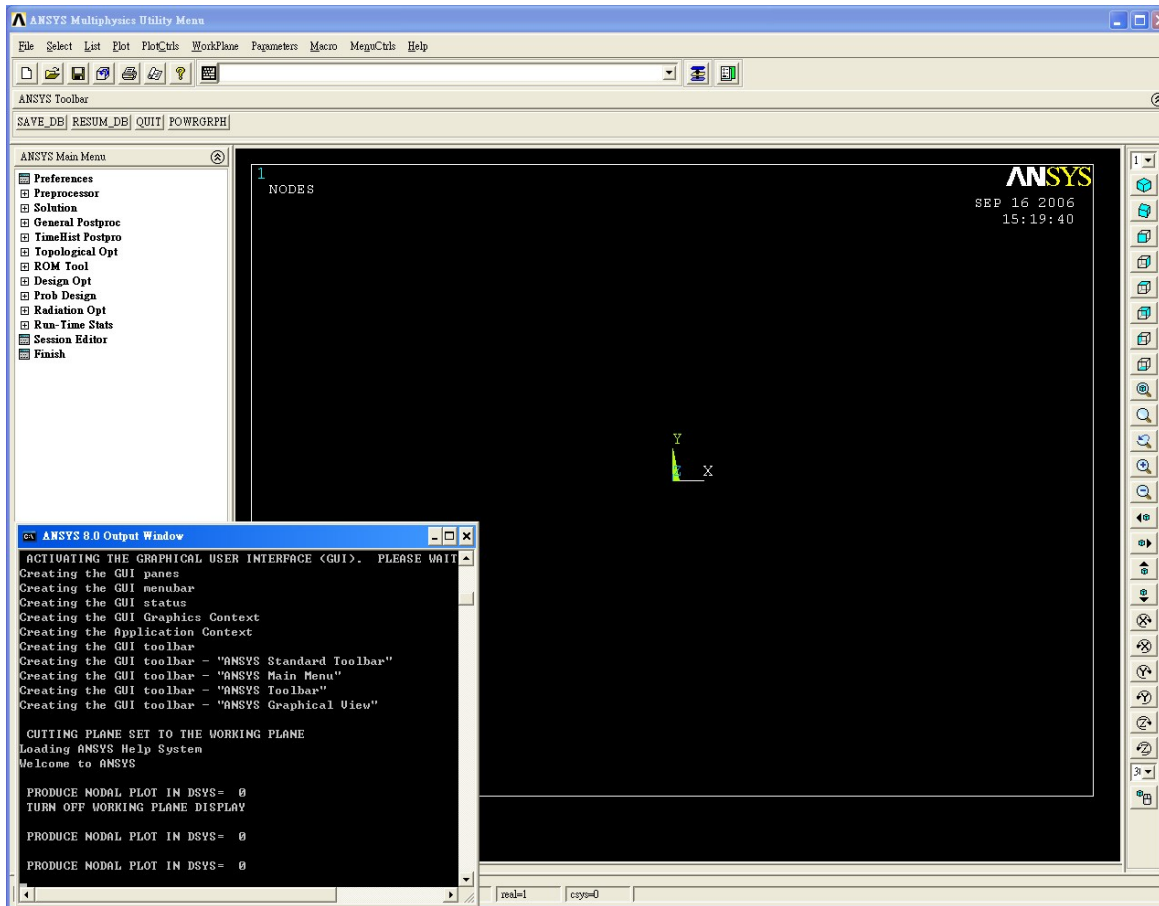

ANSYS Classical(APDL) / Workbench



Biomechanical Analysis of Dental Implant - Workbench

File View Tools Units Extensions Jobs Help

Project

Import... Reconnect Refresh Project Update Project ACT Start Page

Toolbox

Project Schematic

Analysis Systems

- Coupled Field Static
- Coupled Field Transient
- Design Assessment
- Eigenvalue Buckling
- Electric
- Explicit Dynamics
- Fluid Flow - Blow Molding (Polyflo)
- Fluid Flow - Extrusion (Polyflow)
- Fluid Flow (CFX)
- Fluid Flow (Fluent)
- Fluid Flow (Polyflow)
- Harmonic Acoustics
- Harmonic Response
- Hydrodynamic Diffraction
- Hydrodynamic Response
- IC Engine (Fluent)
- Magnetostatic
- Modal
- Modal Acoustics
- Random Vibration
- Response Spectrum
- Rigid Dynamics
- Static Acoustics
- Static Structural
- Steady-State Thermal
- Thermal-Electric
- Throughflow
- Throughflow (BladeGen)
- Topology Optimization
- Transient Structural
- Transient Thermal
- Turbomachinery Fluid Flow

Component Systems

Custom Systems

View All / Customize...

Ready

Job Monitor... No DPS Connection Show Progress Hide 19 Messages

Project Schematic

A

- Static Structural
- Engineering Data
- Geometry
- Model
- Setup
- Solution
- Results

test

Messages

A	B	C	D
1	Type	Association	Date/Time
	Text		

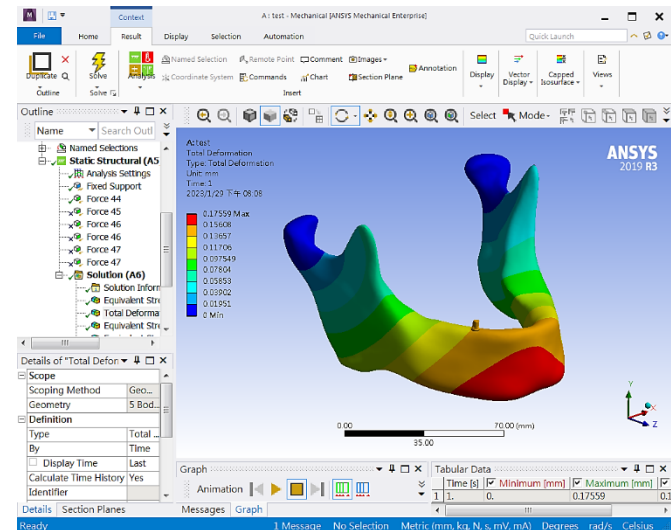
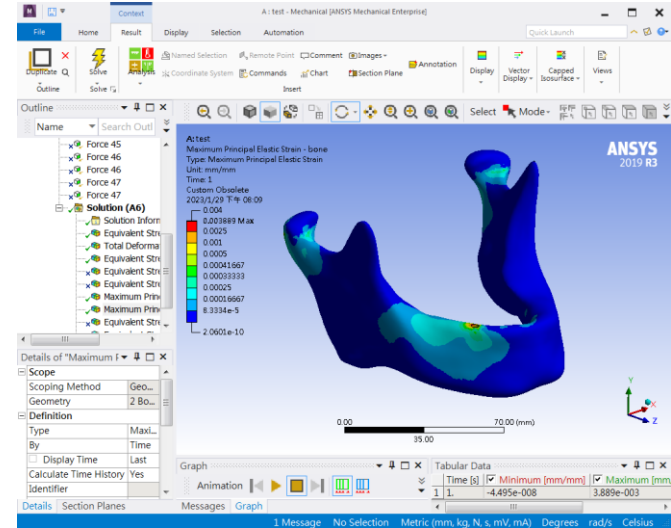

- **Workbench**提供一個強大的之模擬分析軟體，並提供參數化及人性化界面供大部分使用者容易使用

- **優點**

- 模型建構能力佳
- 與**CAD**軟體結合及通用性高
- 建模形之運算及網格切割能力佳
- 結果圖案美觀效果佳

- **缺點**

- 較多設定已被預設→易造成分析結果不正確
- 部分高級分析技術指令仍需在**APDL**可執行

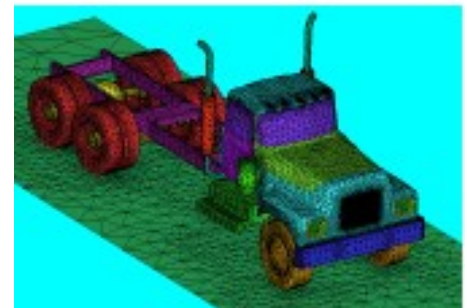
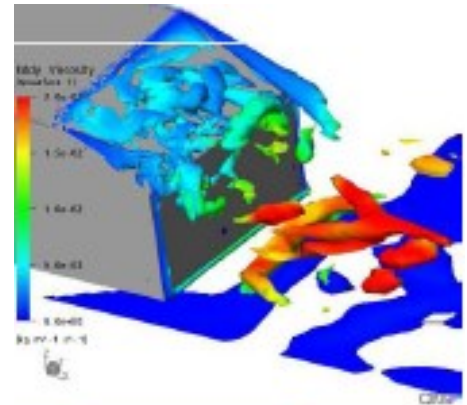
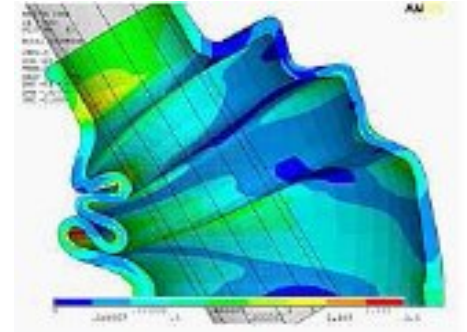



有限元素分析步驟

■ 分析步驟，大致可分成以下階段：

1. 分析類型選定
2. 材料性質設定
3. 幾何外形建模or外部模型輸入與編輯
4. 有限元素網格(Mesh)之建立
5. 邊界條件設定(負荷與接觸)
6. 求解器設定→**Solve**
7. 觀察分析結果，輸出數據/圖形/動畫

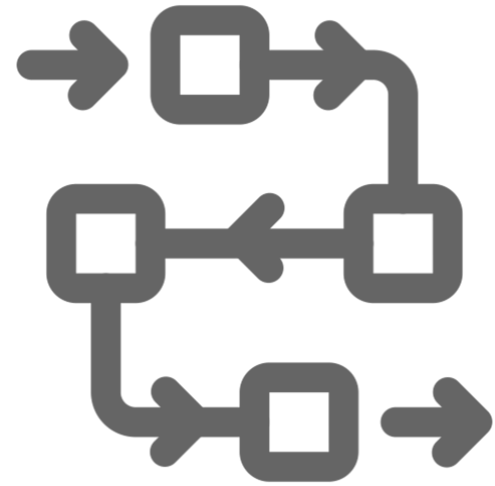

■ 所有的有限元素分析軟體都可大略切割成三部分：

- 前處理器(pre-processor)
- 求解器(solver)
- 後處理器(post-processor)

ANSYS 使用入門 – Ex.1



厚度2mm,左端固定,右端施力 $F=10\text{N}$,求應力分佈,材料為鋼

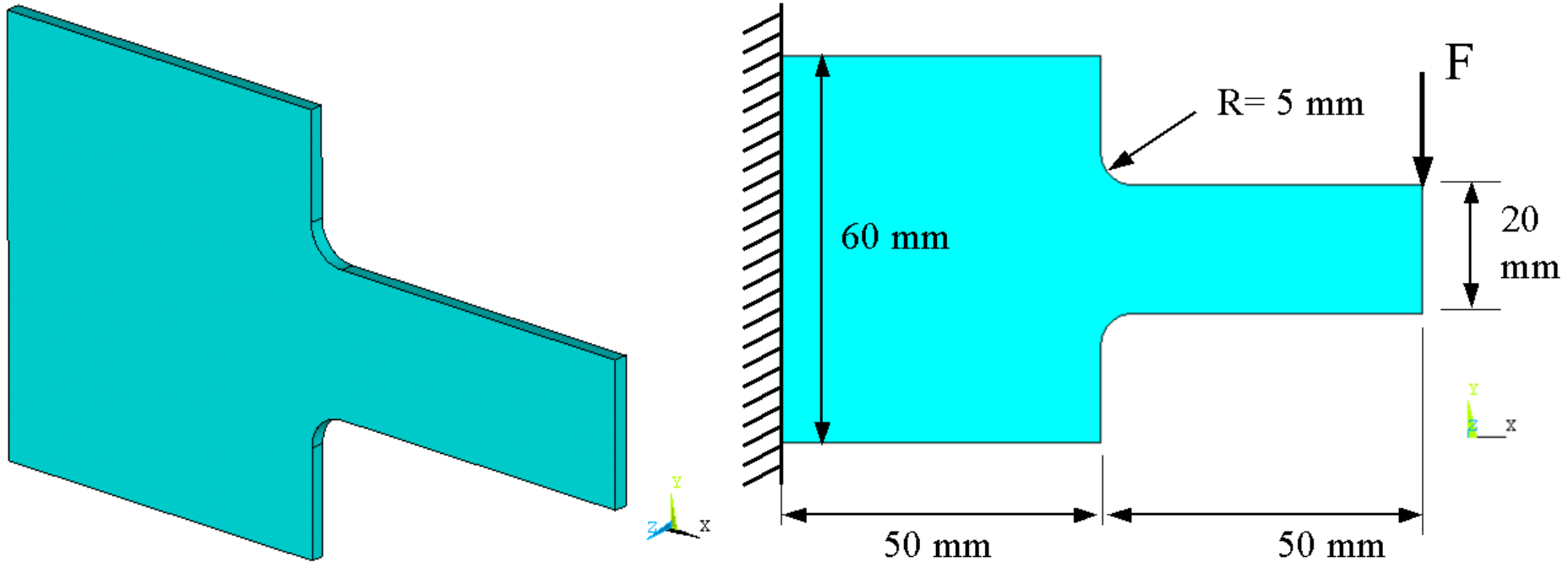

ANSYS 使用入門 - Ex1

學習目標
• 分析步驟

厚度2mm,左端固定,右端施力 $F=10\text{N}$,求應力分佈,材料為鋼

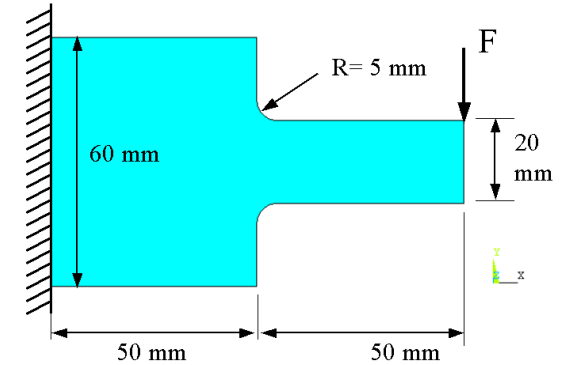
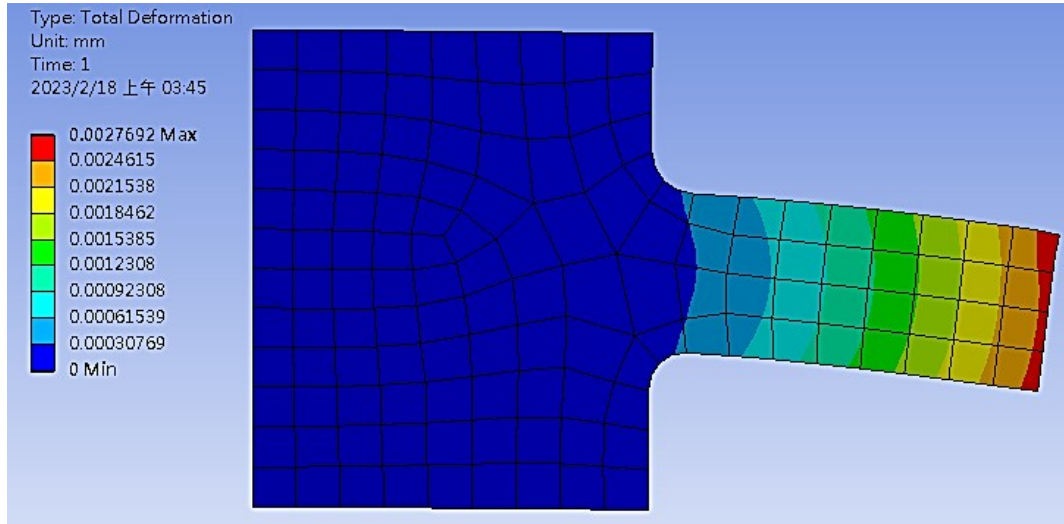

變形量
Total Deformation

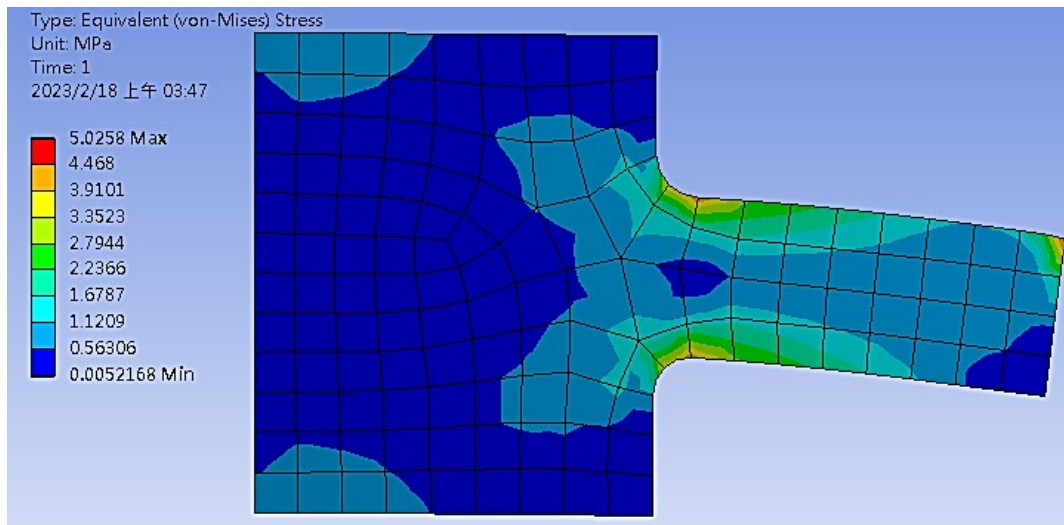

等效應力
Equivalent Stress



■ 有限元素分析程序摘要

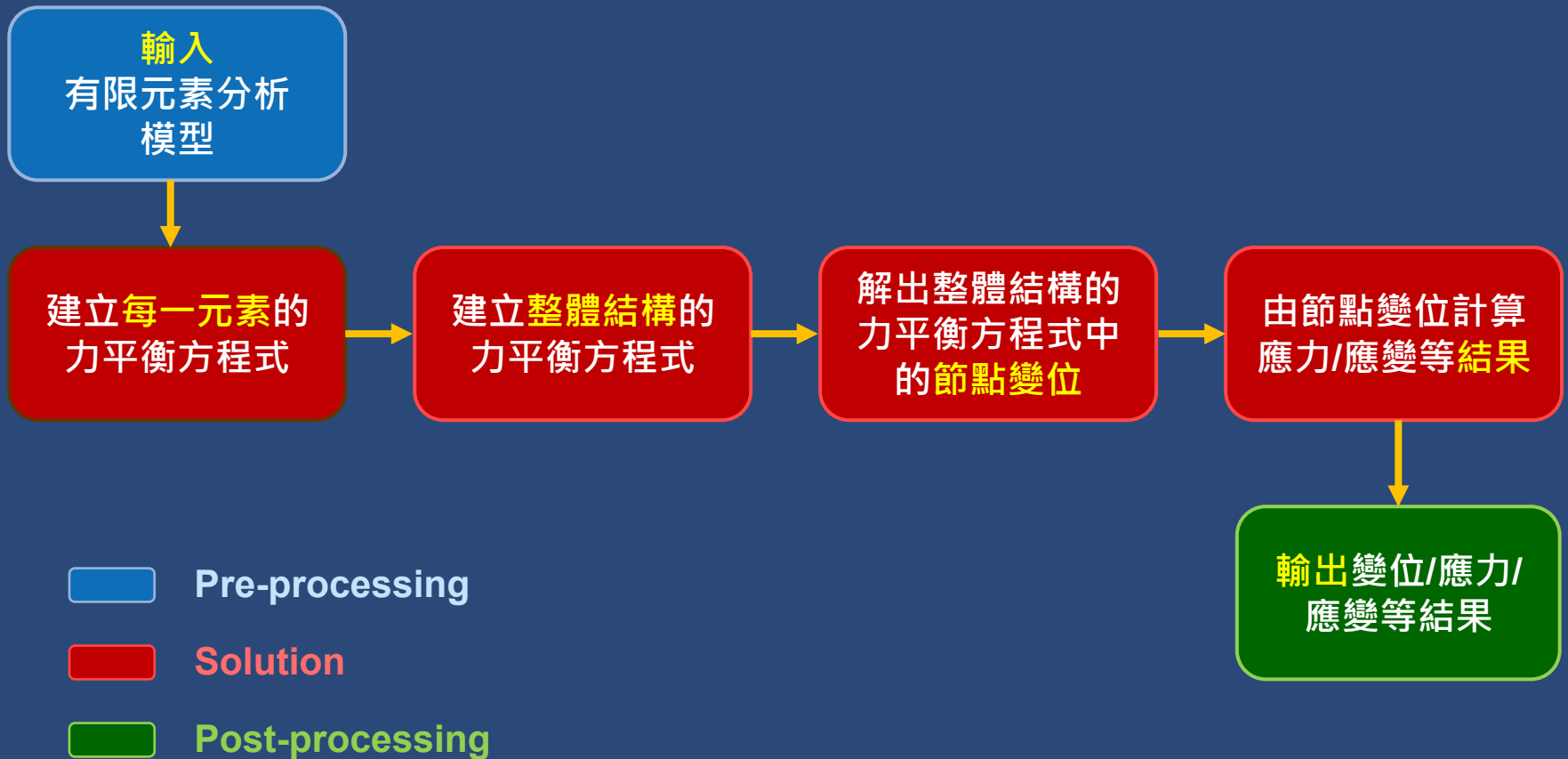



有限元素分析步驟

■ 分析步驟，大致可分成以下階段：

1. 分析類型選定
2. 材料性質設定
3. 幾何外形建模or外部模型輸入與編輯
4. 有限元素網格(Mesh)之建立
5. 邊界條件設定(負荷與接觸)
6. 求解器設定→**Solve**
7. 觀察分析結果，輸出數據/圖形/動畫

	A
1	Static Structural
2	Engineering Data ✓
3	DM Geometry ✓
4	Model ✓
5	Setup ?
6	Solution ⚡
7	Results ⚡

■ 所有的有限元素分析軟體都可大略切割成三部分

- 前處理器(pre-processor)
- 求解器(solver)
- 後處理器(post-processor)

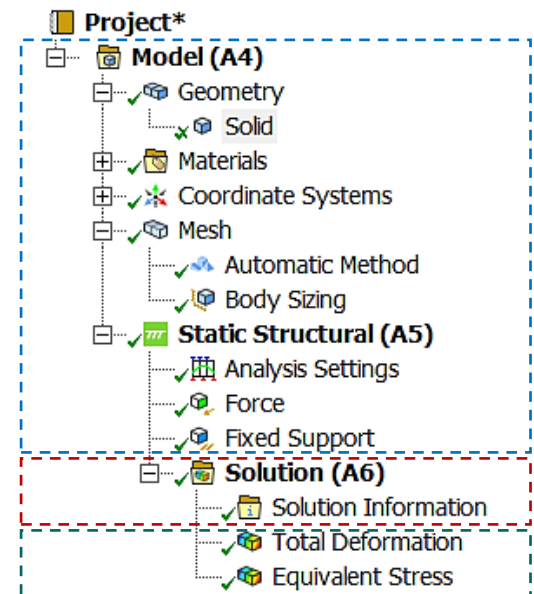



Fundamental Concepts in FEM

- 實際的物理問題很難利用單一的微分方程式描述，更無法順利求其解析(analytical solution)解
- 有限元素法(Finite Element Method)的精神是將複雜的幾何外形的結構物體切割成許多簡單的幾何形狀稱之為**元素(element)**，元素與元素間以**節點(node)**相連
- 由於元素是簡單的幾何形狀，故可順利寫出元素的力平衡方程式並求得節點上之變位、應變及應力等
- 藉由內插法求得元素內任意點的變位、應變及應力等

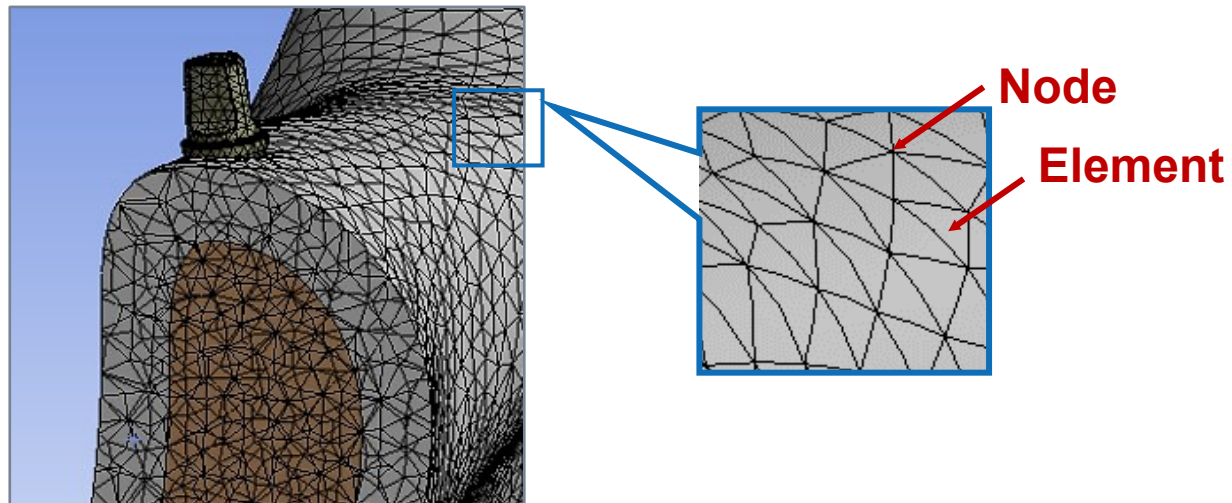



- 求出節點的變位後 $[k]\{d\}=\{f\}$ ，透過下式可求得應變及應力

$$\varepsilon_x = \frac{\partial u_x}{\partial x}$$

$$\varepsilon_y = \frac{\partial u_y}{\partial y}$$

$$\varepsilon_z = \frac{\partial u_z}{\partial z}$$

$$\gamma_{xy} = \frac{\partial u_x}{\partial y} + \frac{\partial u_y}{\partial x}$$

$$\gamma_{yz} = \frac{\partial u_y}{\partial z} + \frac{\partial u_z}{\partial y}$$

$$\gamma_{zx} = \frac{\partial u_z}{\partial x} + \frac{\partial u_x}{\partial z}$$

$$\varepsilon_x = \frac{\sigma_x}{E} - \nu \frac{\sigma_y}{E} - \nu \frac{\sigma_z}{E}$$

$$\varepsilon_y = \frac{\sigma_y}{E} - \nu \frac{\sigma_z}{E} - \nu \frac{\sigma_x}{E}$$

$$\varepsilon_z = \frac{\sigma_z}{E} - \nu \frac{\sigma_x}{E} - \nu \frac{\sigma_y}{E}$$

$$\gamma_{xy} = \frac{\tau_{xy}}{G}$$

$$\gamma_{yz} = \frac{\tau_{yz}}{G}$$

$$\gamma_{zx} = \frac{\tau_{zx}}{G}$$

Fundamental Concepts in FEM



一般桁架結構係由細長的桿件組合而成，用以建構實際之工程結構，在桿件之接點通常以螺栓或焊接方式連接，或直接用鉸接 (pin joint)。分析桁架結構通常假設 [1.1]：

Calculating

- (1) 各桁架元件 (桿件) 係以無摩擦 (frictionless) 之鉸連接。
- (2) 桿件呈細長形，即桿件長度遠大於桿件截面尺寸。
- (3) 桿件只可承受沿桿件長度方向之拉伸 (tension) 或壓縮 (compressive) 之外力負荷，不可承受彎曲力矩 (bending moment) 或剪力 (shear force)。
- (4) 桿件為均質而且具相同截面。
- (5) 所有外力負荷只作用在接點 (joint)。
- (6) 桿件之應力符合虎克定律。
- (7) 桿件之應變為線性。
- (8) 桿件之效應相當於一線性彈簧 (linear spring)。

Bending moment

Solid mechanics

電腦輔助 工程分析之實務與應用

王栢村 編著

附ANSYS軟體
輸入檔之磁片

全華科技圖書股份有限公司 印行



圖1-1 工程分析流程



Fundamental Concepts in FEM

■ FEM

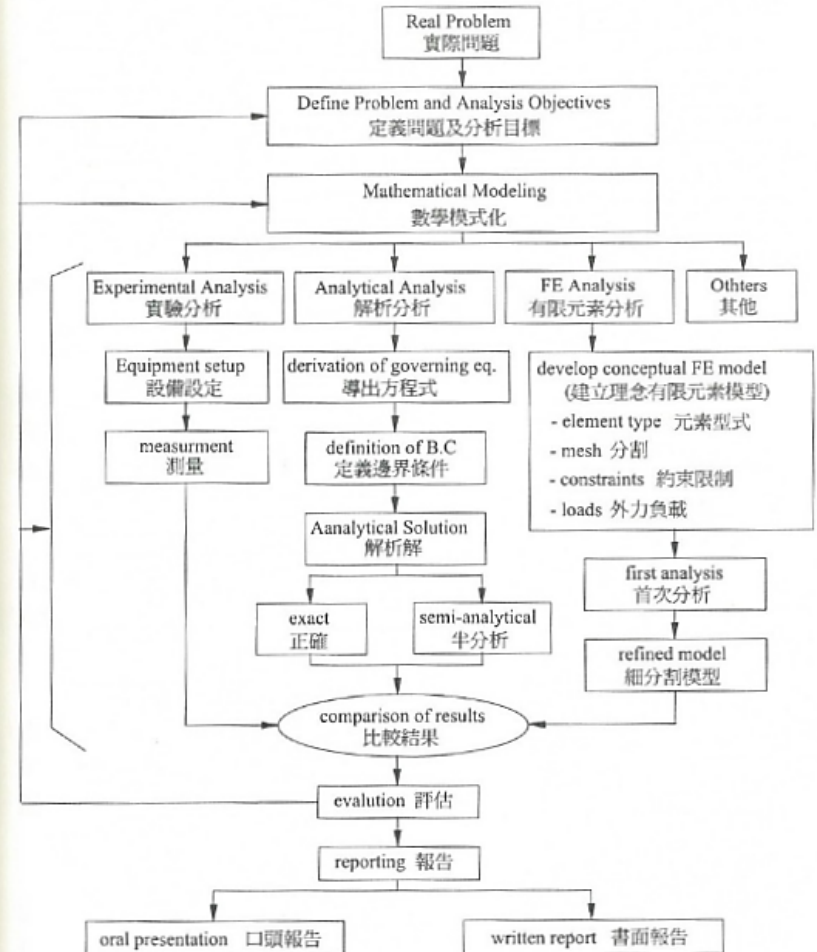
- A numerical method for solving P.D.E.

■ Advantage

- Can handle
- Arbitrary geometry & material complexity
- Provide more detailed mechanical responses
- Becoming a powerful analytical tool

■ Disadvantage

- Require large amount of input data
- Computation time



Fundamental Concepts in FEM

- The simulated analytical results could be **plausible** and **incredulous** by

- Inaccurately geometry approximation
- Material distribution
- Uncertainty loading and boundary condition

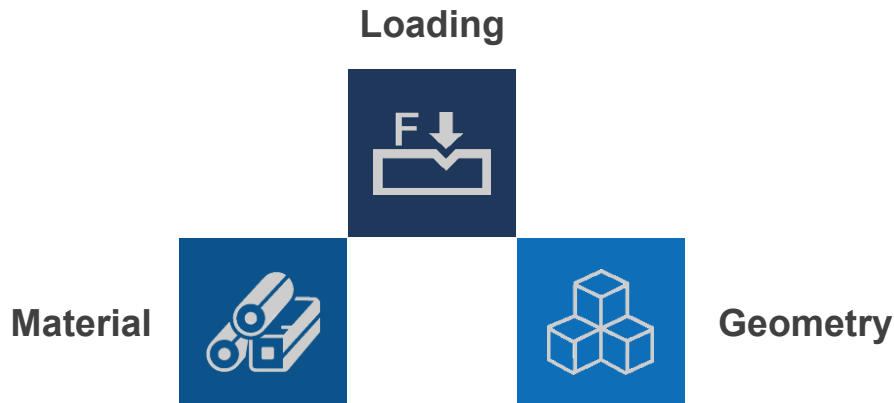

Garbage in, garbage out.

- Pre-processing technique of FEM

- **Meshing procedure** for bio-structures is still a big obstacle especially in 3D applications

3D Modeling for Biological Structure

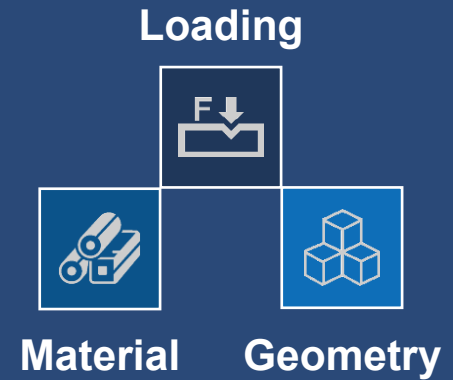
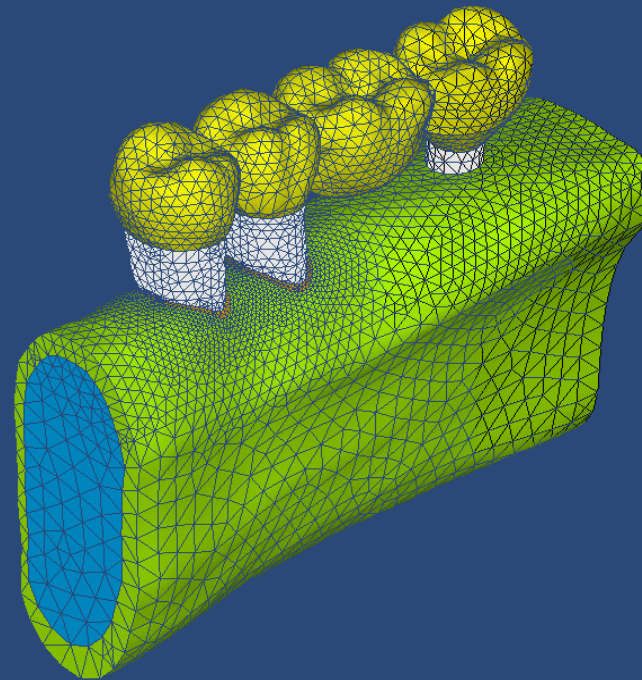

C.L. Lin, J.C. Wang*, S.T. Chen, "Evaluation of stress induced of implant type and number of splinted teeth in different periodontal supported tooth-implant supported FPDs: a nonlinear finite element analysis", *Journal of Periodontology*, Vol. 81, pp.121-130, 2010.

General Concept of CAE



■ Professional knowledge (Physical problem)

- **Structural mechanics**
- Thermal (heat transform)
- Fluid flow
- Electro-magnetic, etc.

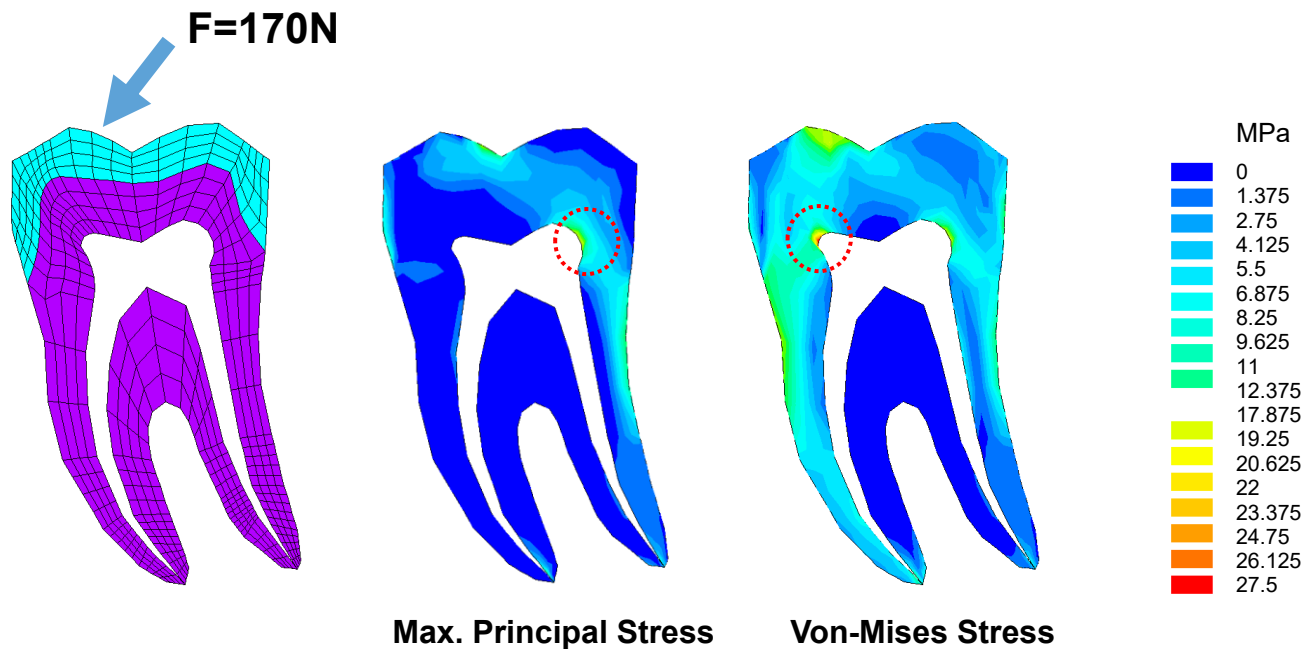
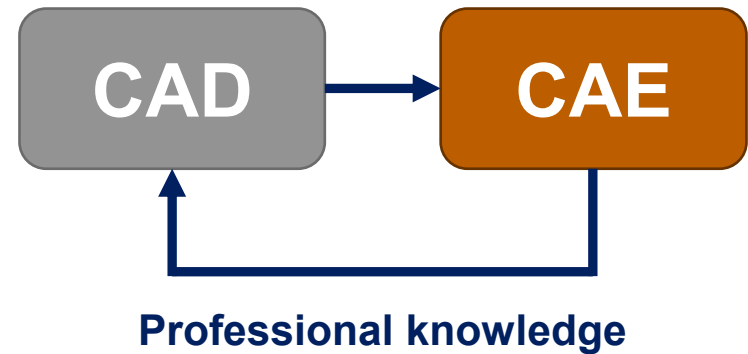

03 **Design Modeler**

建模功能介紹



Introduction of ANSYS Workbench



■ 選定分析類型

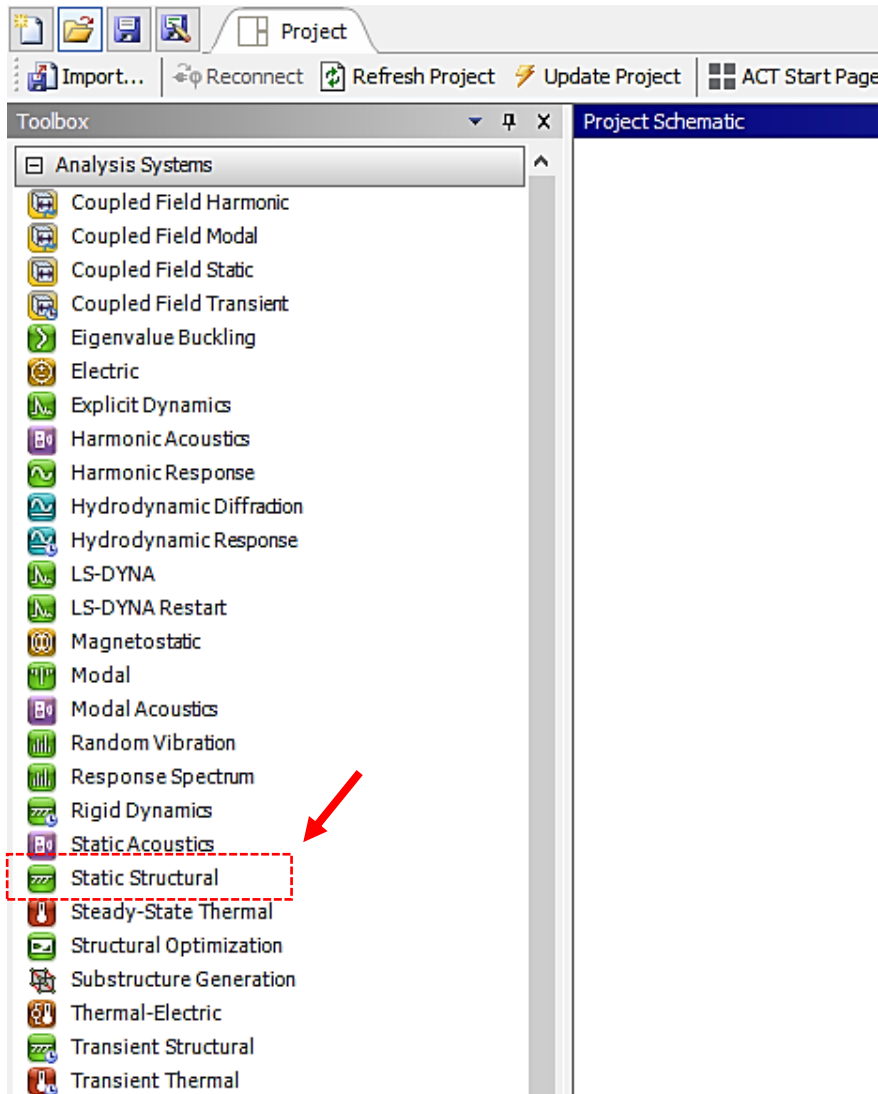

A	
1	Static Structural
2	Engineering Data ✓
3	DM Geometry ✓
4	Model ✓
5	Setup ?
6	Solution ⚡
7	Results ⚡



Introduction of ANSYS Workbench

■ 分析步驟，大致可分成以下階段：

1. 分析類型選定
2. 材料性質設定
3. 幾何外形建模or外部模型輸入與編輯
4. 有限元素網格(Mesh)之建立
5. 邊界條件設定(負荷與接觸)
6. 求解器設定→**Solve**
7. 觀察分析結果，輸出數據/圖形/動畫

	A	
1	Static Structural	
2	Engineering Data	✓
3	DM Geometry	✓
4	Model	✓
5	Setup	?
6	Solution	⚡
7	Results	⚡

■ 所有的有限元素分析軟體都可大略切割成三部分

- 前處理器(pre-processor)
- 求解器(solver)
- 後處理器(post-processor)

- ✓ 最新的狀態(數據輸入輸出完整)
- 需要刷新(重新整理)：上游數據已改變，需更新單元
- 需要注意：可能需要修改本項或上游資訊設定
- 需要更新：數據已改變，輸出需重新產生

Introduction of ANSYS Workbench

■ Geometry - Design Modeler

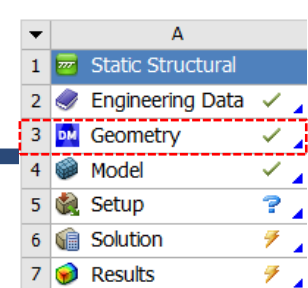

視窗控制

選取工具

3D繪圖功能

結構樹

繪圖視窗

屬性視窗

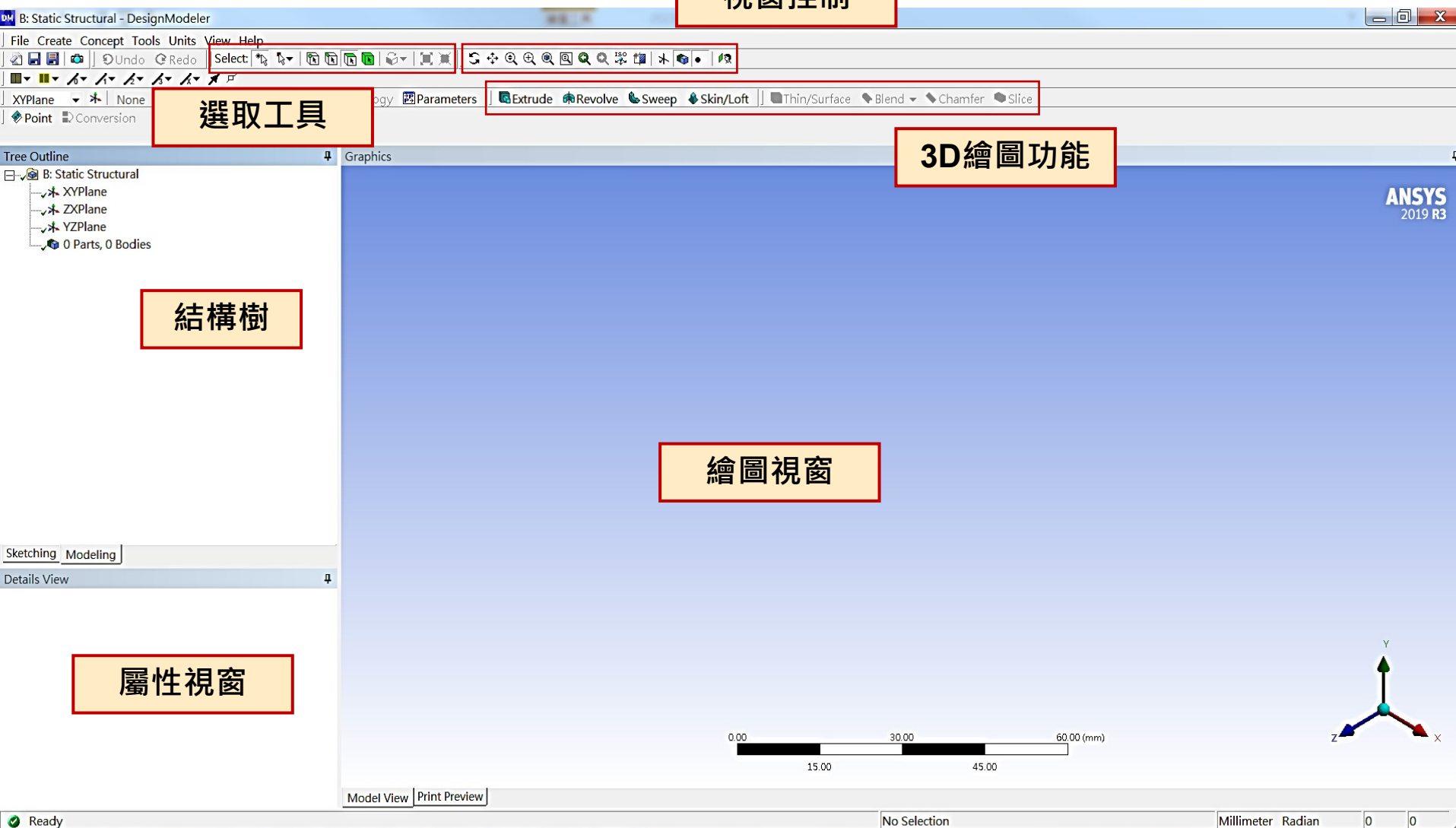

Introduction of ANSYS Workbench

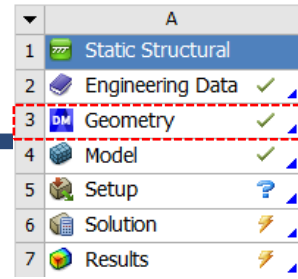

■ Geometry - Design Modeler

➤ 2D Sketching(草圖模式)

✓ 包括建構二維幾何模型。此二維幾何模型可作為3D模型建構之依據。

➤ 3D建模

✓ 將草圖進行拉伸/旋轉等操作，建構3D幾何模型。

➤ CAD模型輸入

✓ 直接導入自**商業化CAD軟體**(Creo Parametric, Solidworks, Autodesk Inventor...)或**逆向工程軟體**(Materialise Mimics/3-Matic...)輸出之實體模型進入，並對其進行修正。

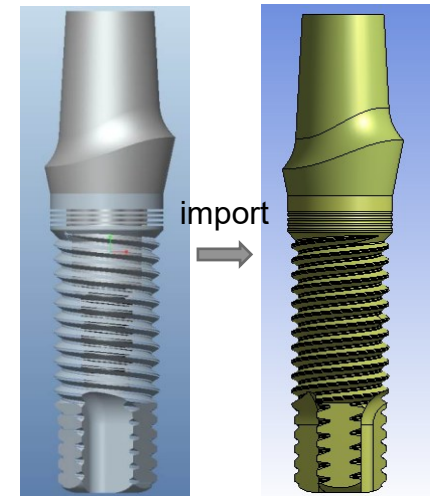
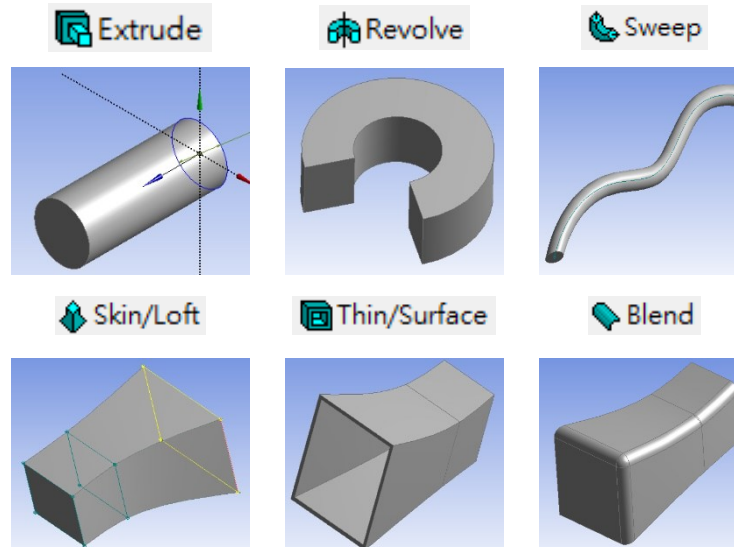
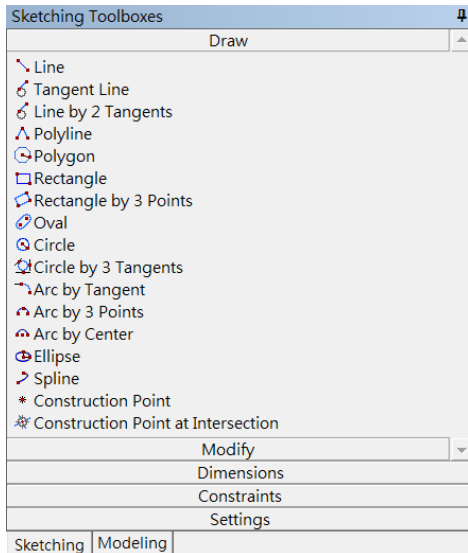

Creo

Workbench

Extra exercise



- 利用Design Modeler 畫出3D 圖

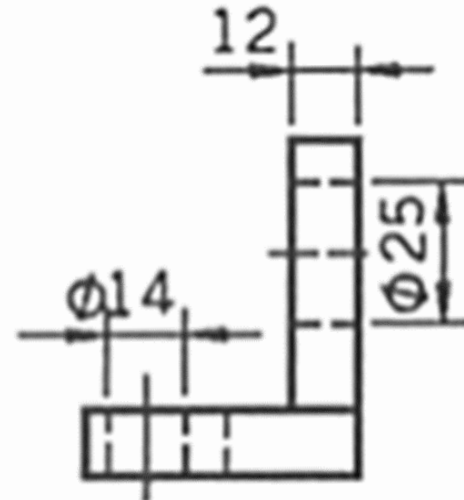
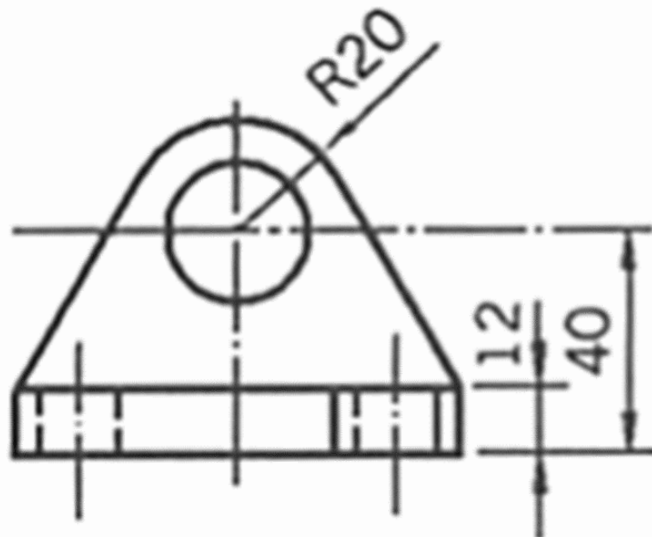
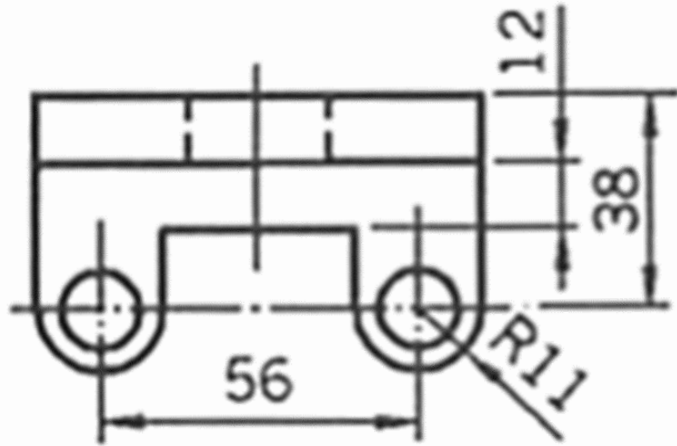

2D Modeling – Ex.2 (來源：成功大學李輝煌教授)



學習目標
• 2D Sketching

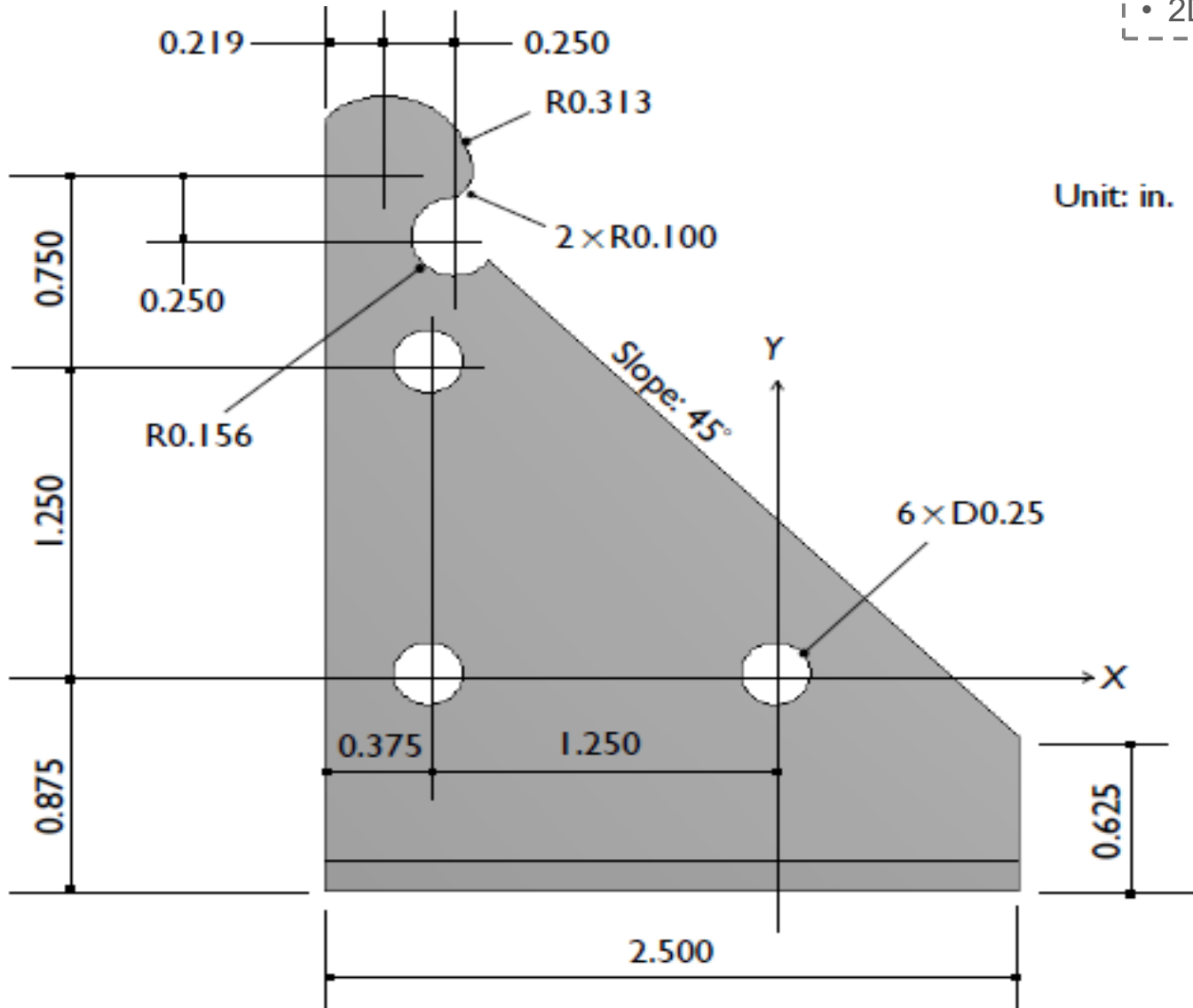

3D Modeling – Ex.3 (來源：成功大學李輝煌教授)



- 學習目標
- Extrude-add
 - New plane
 - Blend

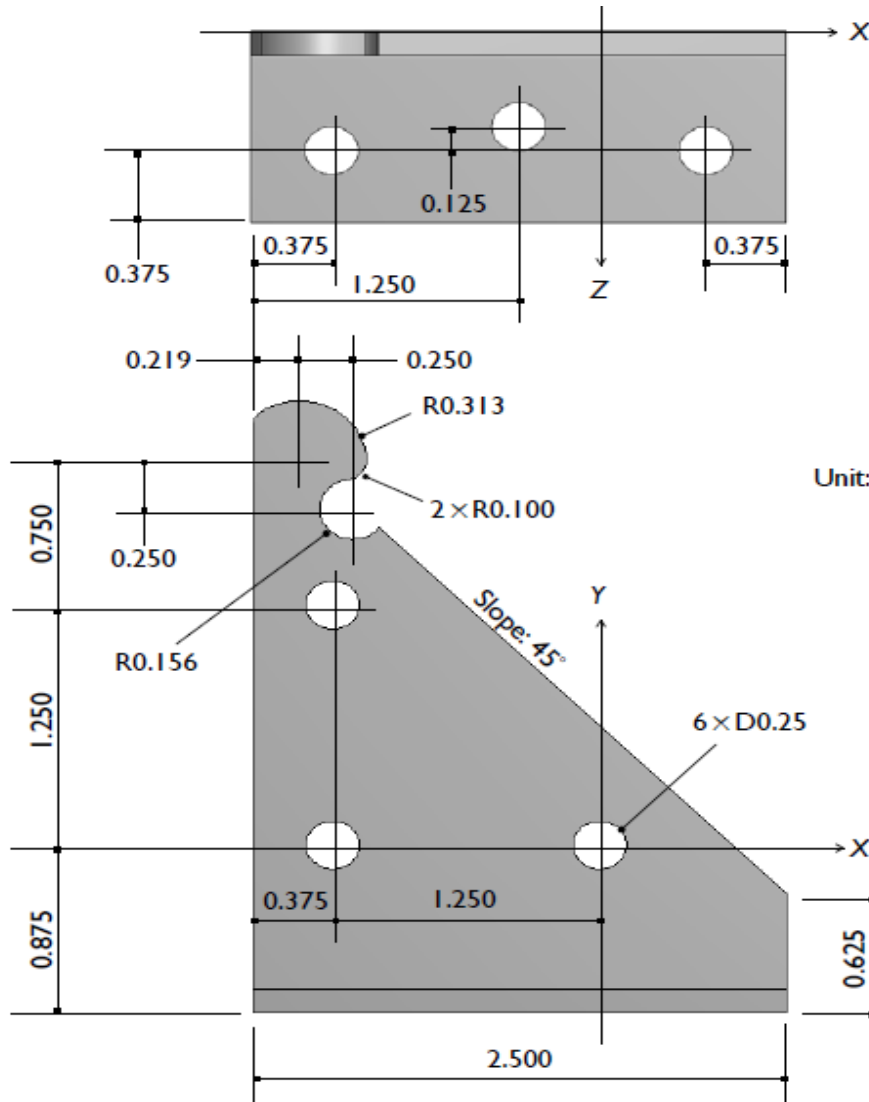
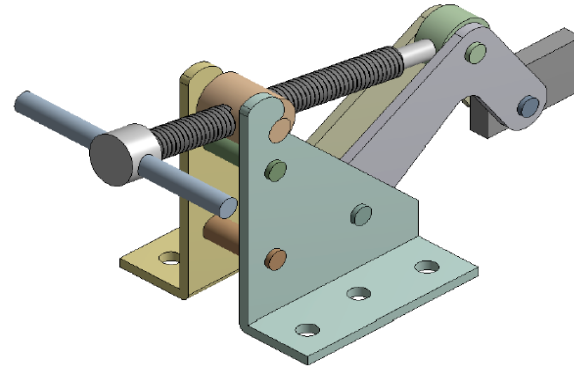

Unit: in.

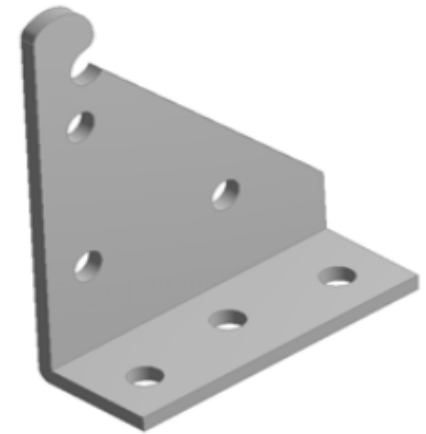
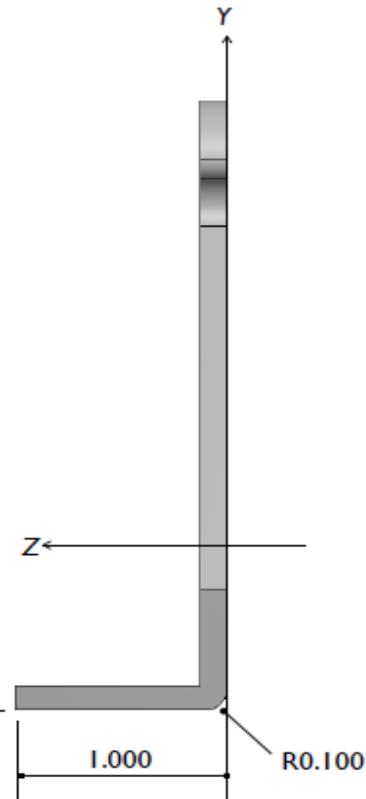

3D Modeling – Ex.4 (來源：ANSYS Workbench 有限元分析從入門到精通)

學習目標

- Extrude-cut
- New sketch

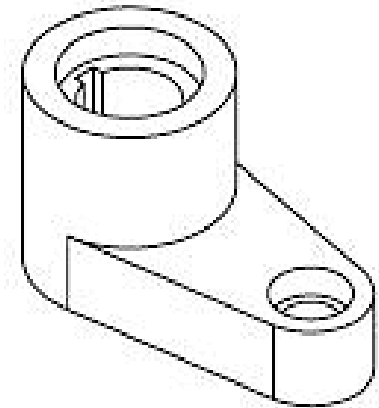
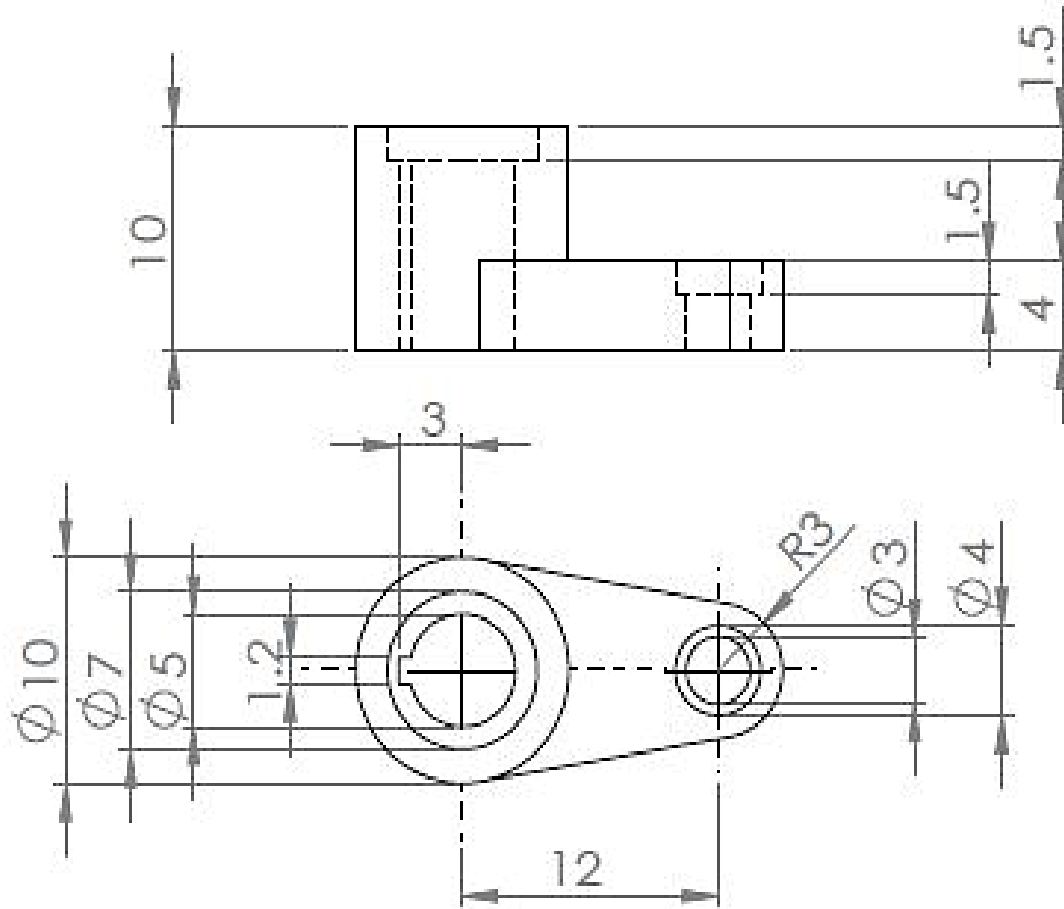

04

Static Structural Analysis

結構分析介紹





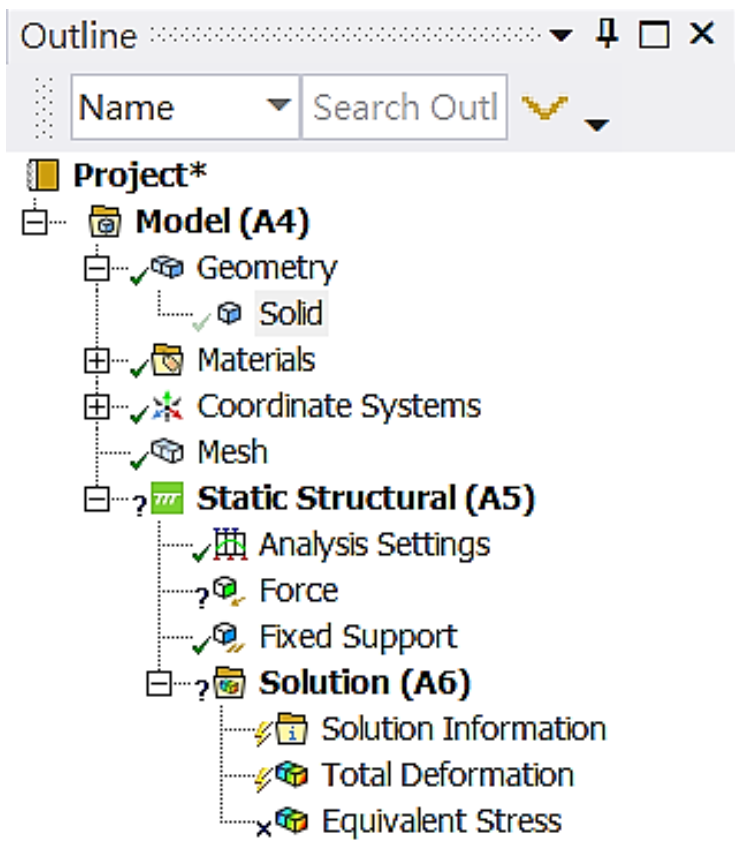

Introduction of ANSYS Workbench

■ 結構樹狀態顯示

A	
1	Static Structural ✓
2	Engineering Data ✓
3	DM Geometry ✓
4	Model ✓
5	Setup ?
6	Solution ⚡
7	Results ⚡



-  說明分支全部被定義
-  說明輸入的數據不完整
-  說明需要求解
-  說明被抑制，不能被求解
-  說明體積或零件被隱藏

Introduction of ANSYS Workbench

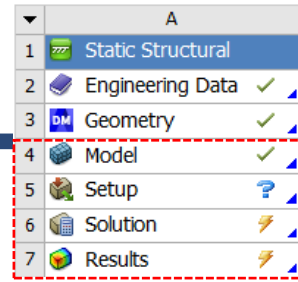

■ Detail視窗

Details of "Force" ▾ ⚙ □ ×

Scope	
Scoping Method	Geometry Selection
Geometry	1 Edge
Definition	
Type	Force
Define By	Components
Coordinate System	Global Coordinate System
<input type="checkbox"/> X Component	0. N (ramped)
<input type="checkbox"/> Y Component	0. N (ramped)
<input type="checkbox"/> Z Component	0. N (ramped)
Suppressed	No

Details of "Total Deformation" ▾ ⚙ □ ×

Scope	
Scoping Method	Geometry Selection
Geometry	All Bodies
Definition	
Type	Total Deformation
By	Time
<input type="checkbox"/> Display Time	Last
Calculate Time History	Yes
Identifier	
Suppressed	No
Results	
<input type="checkbox"/> Minimum	0. mm
<input type="checkbox"/> Maximum	2.6374e-003 mm

白色區域	可編輯的資料設定
灰色區域	不可編輯的資料，僅供顯示信息數據
黃色區域	未完成的資料設定(待輸入)
粉色區域	尚未更新的結果數據(需重新求解)

Introduction of ANSYS Workbench

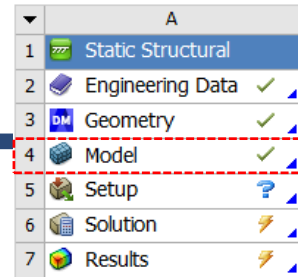

■ Model

- **Geometry:** 模型材料給定
- **Mesh:** 網格分割

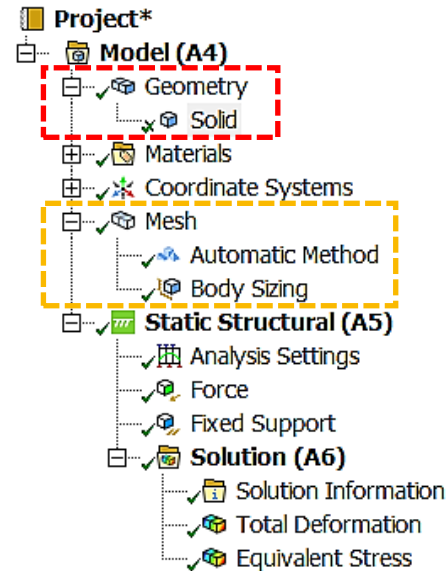

Details of "Solid"

Graphics Properties	
Definition	
<input type="checkbox"/> Suppressed	No
Stiffness Behavior	Flexible
Coordinate System	Default Coordinate System
Reference Temperature	By Environment
Treatment	None
Material	
Assignment	Steel
Nonlinear Effects	Yes
Thermal Strain Effects	Yes
Bounding Box	

Introduction of ANSYS Workbench

■ 邊界條件給定

	A
1	Static Structural
2	Engineering Data ✓
3	DM Geometry ✓
4	Model ✓
5	Setup ?
6	Solution ⚡
7	Results ⚡

The screenshot displays the ANSYS Workbench interface. The 'Outline' pane on the left shows the project hierarchy: Project* > Model (A4) > Static Structural (A5). The 'Details of "Static Structural (A5)"' pane at the bottom left shows the 'Definition' section with 'Physics Type' set to 'Structural' and 'Solver Target' set to 'Mechanical APDL'. The 'Insert' menu is open, showing various boundary condition options. A red dashed box highlights the 'Insert' menu and the list of boundary condition options on the right.

Boundary Condition
Acceleration
Standard Earth Gravity
Rotational Velocity
Rotational Acceleration
Pressure
Hydrostatic Pressure
Force
Remote Force
Bearing Load
Bolt Pretension
Moment
Line Pressure
Thermal Condition
Joint Load
Fixed Support
Displacement
Remote Displacement
Frictionless Support
Compression Only Support
Cylindrical Support

Introduction of ANSYS Workbench

■ 解題條件設定

- Step Control
- Number of steps
- Current Step Number
- Step Ends

■ Solver Control

- 解題形式
- 大變形等

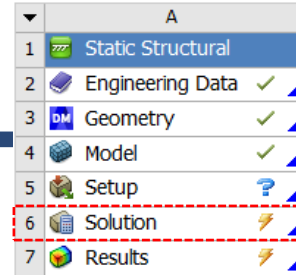
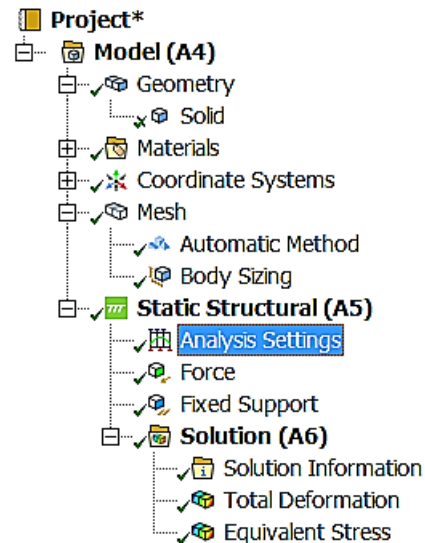

The screenshot shows the 'Details of Analysis Settings' dialog box. The 'Step Controls' section is expanded, showing the following settings:

Step Controls	
Number Of Steps	1.
Current Step Number	1.
Step End Time	1. s
Auto Time Stepping	Program Controlled

The 'Solver Controls' section is also expanded, showing the following settings:

Solver Controls	
Solver Type	Program Controlled
Weak Springs	Off
Solver Pivot Checking	Program Controlled
Large Deflection	Off
Inertia Relief	Off

The 'Rotordynamics Controls', 'Restart Controls', and 'Nonlinear Controls' sections are collapsed. The 'Advanced' section is expanded, showing the following settings:

Advanced	
Inverse Option	No

The 'Output Controls' section is also expanded.

Introduction of ANSYS Workbench

■ 後處理(Post-processing)

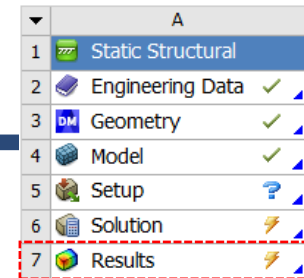

設定顯示方式

Contour設定

- 自訂數值
- 增加色塊
- 自訂色彩

選取結果項目

ANSYS 2019 R3

A: Static Structural
Total Deformation
Type: Total Deformation
Unit: mm
Time: 1
2023/1/31 上午 08:10

0.0026374 Max
0.0023444
0.0020513
0.0017583
0.0014652
0.0011722
0.00087914
0.00058609
0.00029305
0 Min

Graph: 20 Frames, 2 Sec (Aut)

Time [s]	Minimum [mm]	Maximum [mm]	Average [mm]
1.	0.	2.6374e-003	3.672e-004

Ready | No Messages | No Selection | Metric (mm, kg, N, s, mV, mA) | Degrees | rad/s | Celsius

3D Solution – Ex.5 (來源：ANSYS Workbench有限元分析從入門到精通)

試建構機蓋模型，尺寸如圖所示，於中央孔頂端面給一100N-mm順時針方向扭轉，觀察其等效應力，材料選用鋼，設定ELEMENT SIZE為3的MESH。

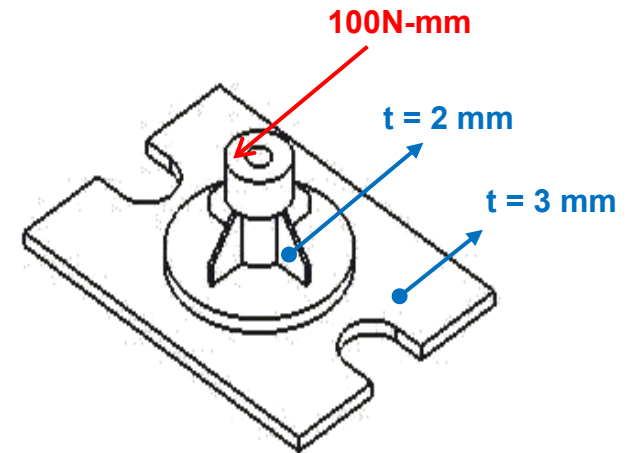
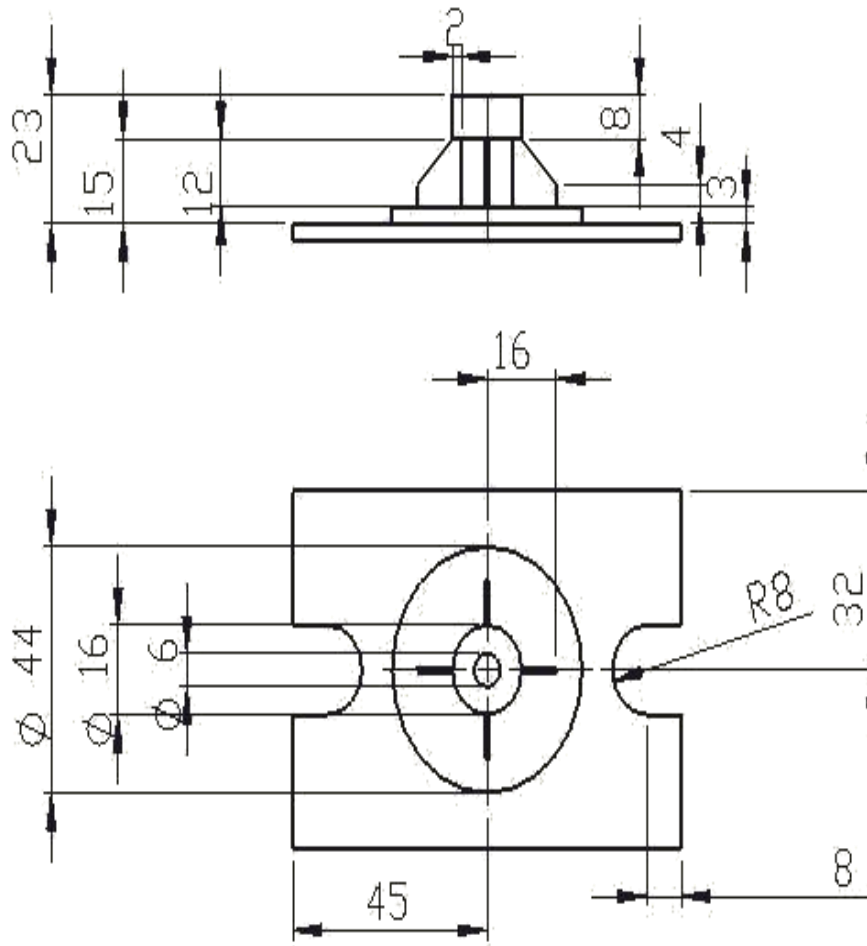

3D Solution – Ex.5

- 學習目標
- Revolve
 - Pattern
 - Mesh-Sizing
 - 解題步驟
 - 基本後處理

試建構機蓋模型，尺寸如圖所示，於中央孔頂端面給一100N-mm順時針方向扭轉，觀察其等效應力，材料選用鋼，設定ELEMENT SIZE為3的MESH。

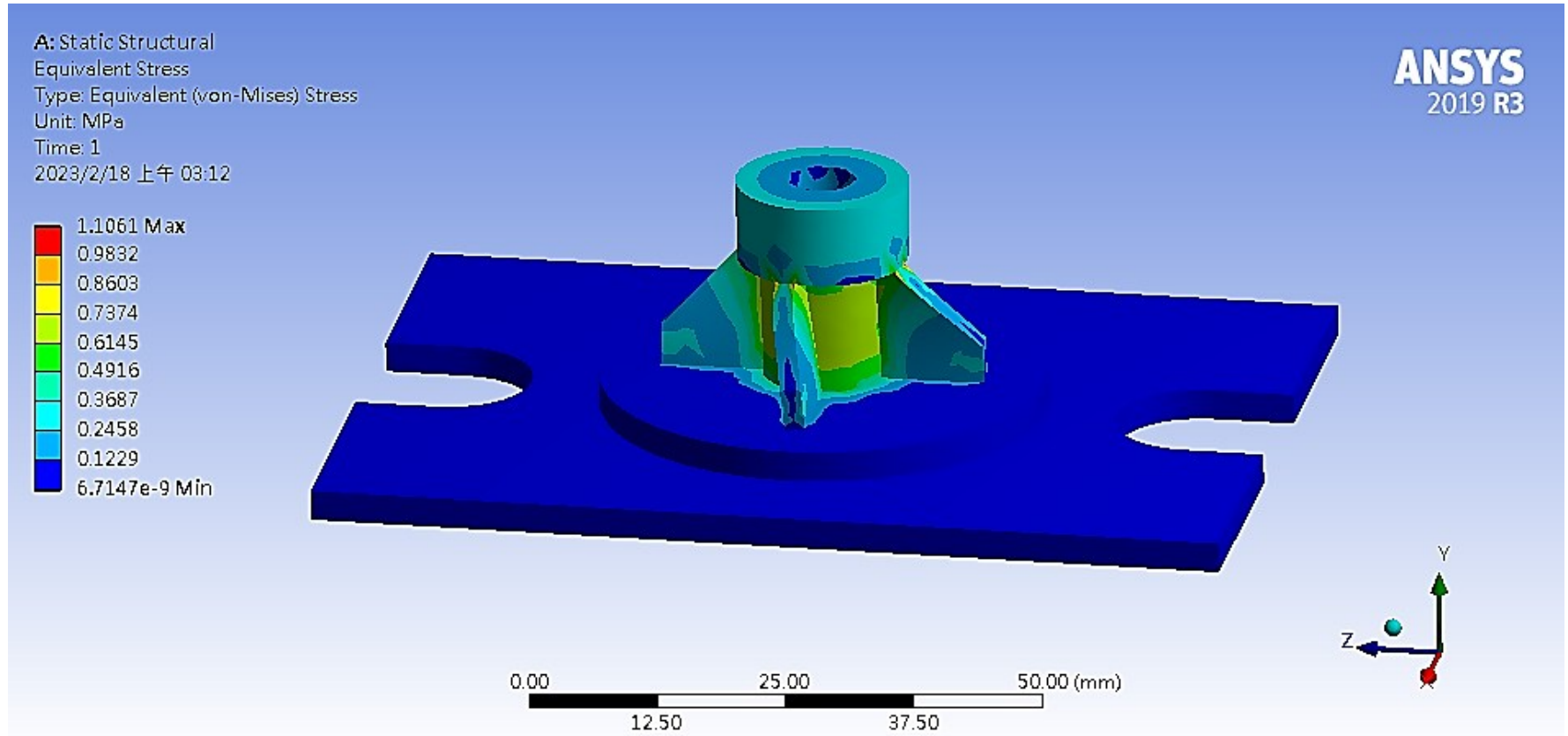

等效應力
Equivalent Stress



Mesh

■ Mesh Approach

➤ Solid modeling

- ✓ Free mesh
- ✓ Mapped mesh
- ✓ ...

網格控制方法非常多元，實際情況依模型、受力狀態、邊界條件而定

	<p>節點數：4 節點自由度：UX,UY (u,v)</p>
	<p>節點數：8 節點自由度：UX,UY (u,v)</p>

Solid Model

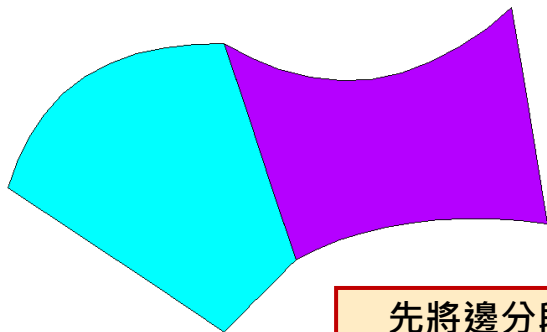

先將邊分段

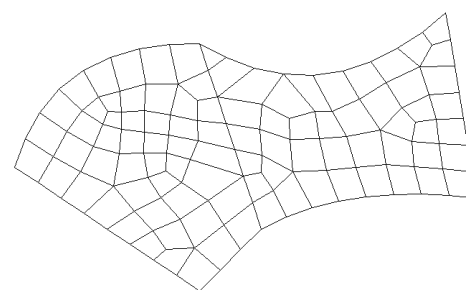

Free Mesh

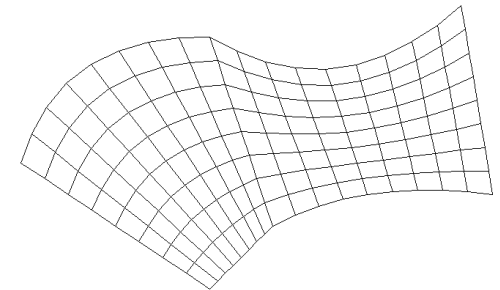

Mapped Mesh

Introduction of ANSYS Workbench

■ 局部網格處理

➤ Method

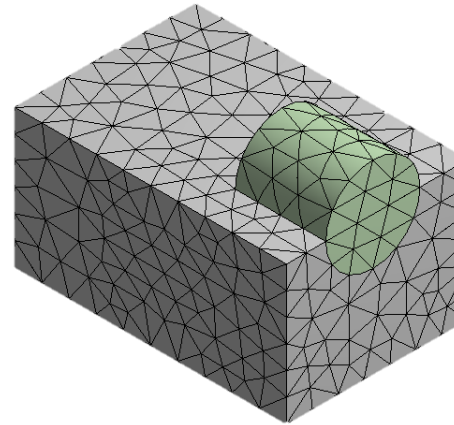
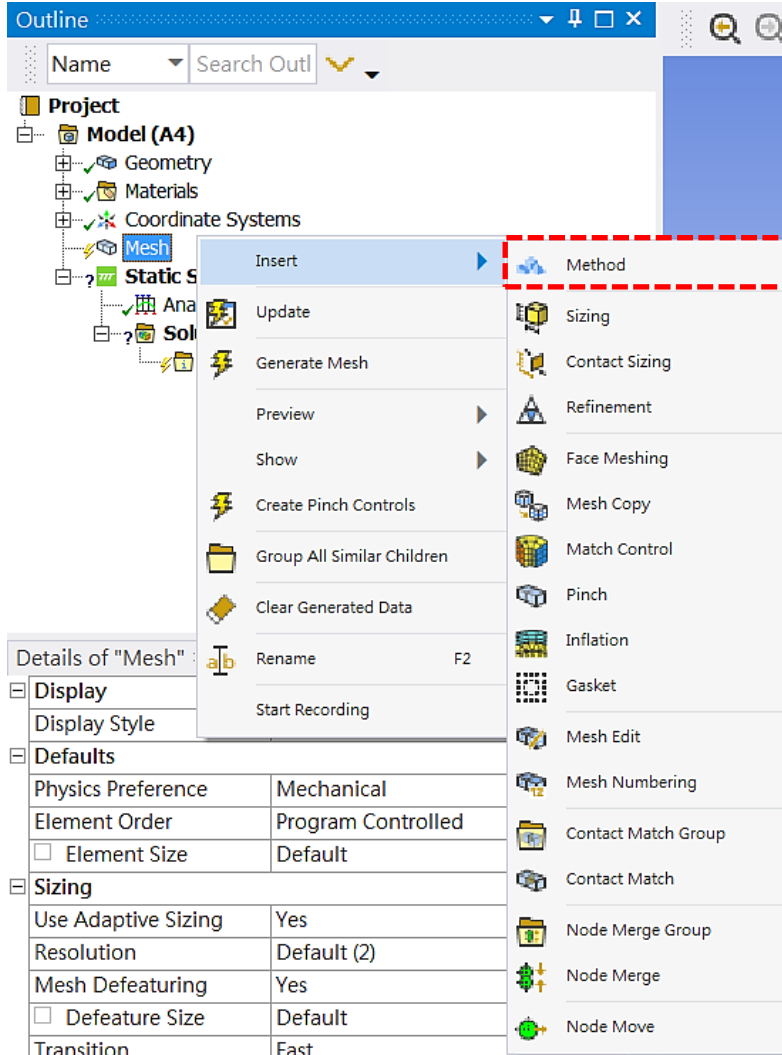
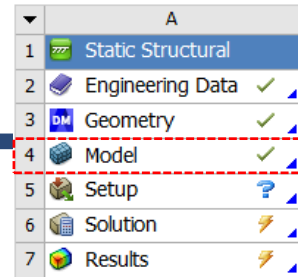

四面體

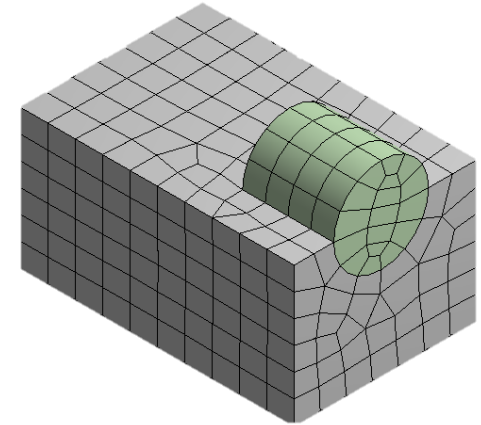

六面體

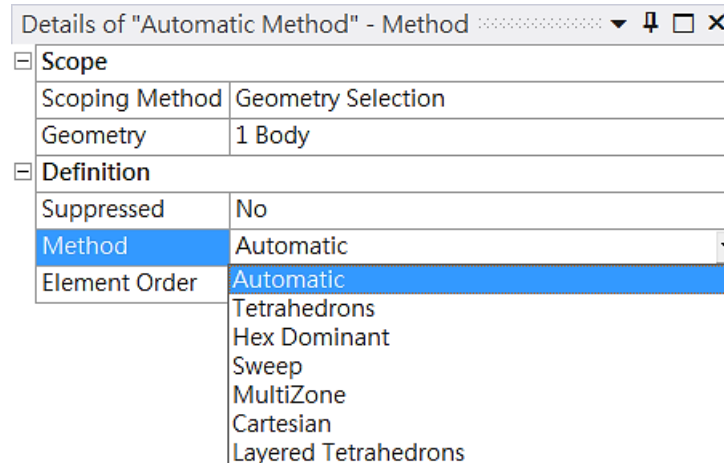

Introduction of ANSYS Workbench

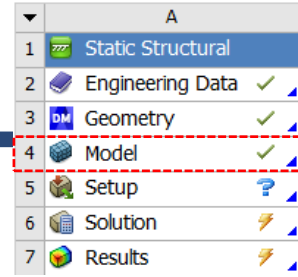

■ 全域網格處理

➤ Sizing

✓ Resolution

Details of "Mesh"	
Display	Use Geometry Setting
Defaults	
Physics Preference	Mechanical
Element Order	Program Controlled
<input type="checkbox"/> Element Size	Default
Sizing	
Use Adaptive Sizing	Yes
Resolution	Default (2)
Mesh Defeaturing	Yes
<input type="checkbox"/> Defeature Size	Default
Transition	Fast
Span Angle Center	Coarse
Initial Size Seed	Assembly
Bounding Box Diagonal	5.2715 in
Average Surface Area	1.4345 in ²
Minimum Edge Length	0.61842 in
Quality	
Inflation	
Advanced	
Statistics	

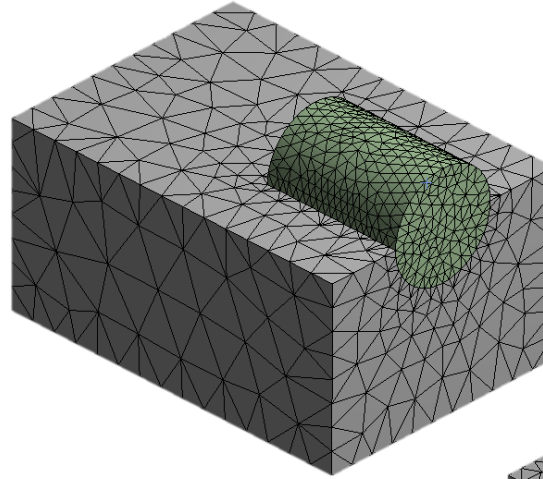

Resolution = 2

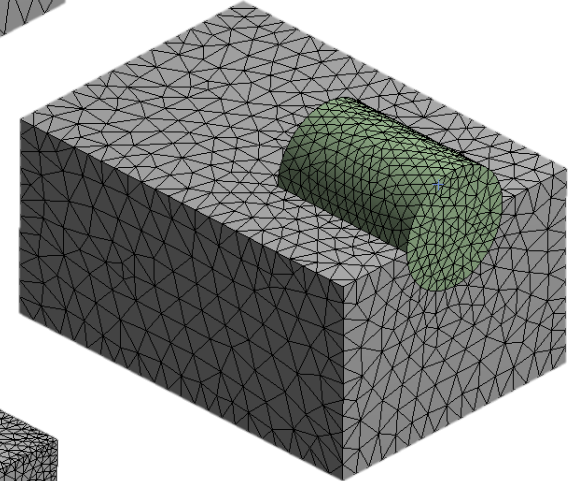

Resolution = 4

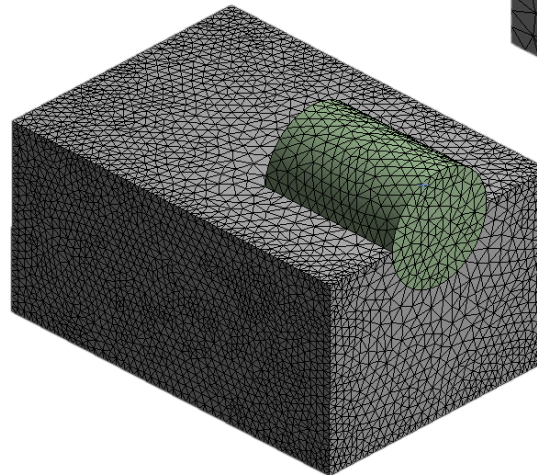

Resolution = 7

Introduction of ANSYS Workbench

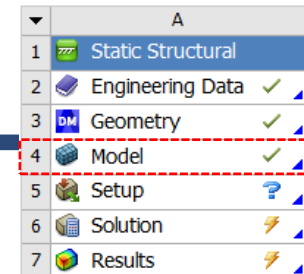

■ 局部網格處理

➤ Sizing

Scope	
Scoping Method	Geometry Selection
Geometry	1 Edge
Definition	
Suppressed	No
Type	Element Size
<input type="checkbox"/> Element Size	Element Size
Advanced	
Number of Divisions	
Sphere of Influence	
Behavior	
Sort	
Bias Type	
No Bias	

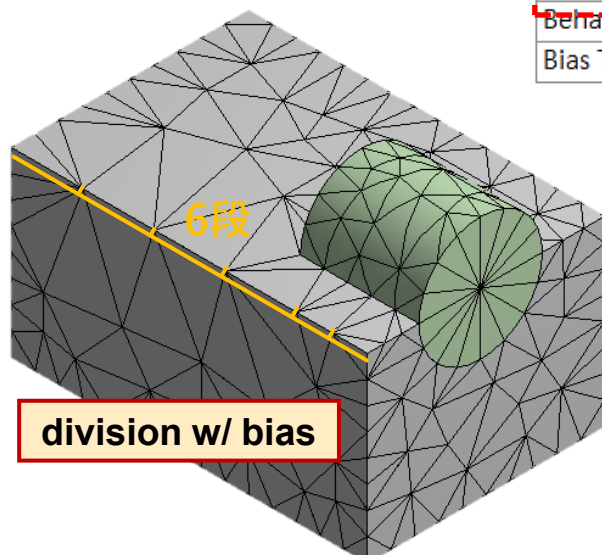

Edge

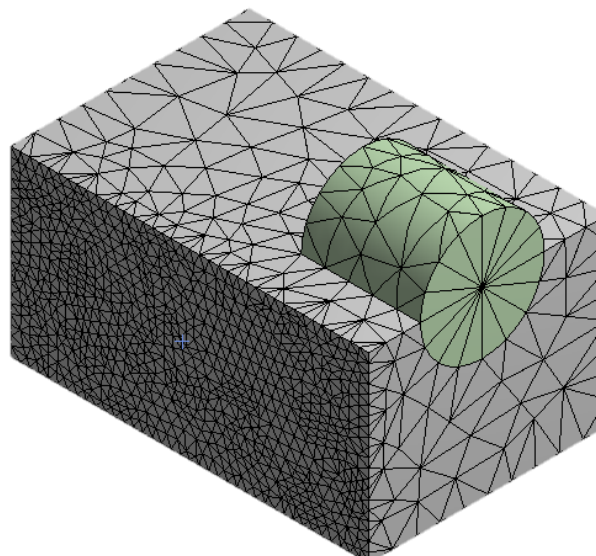

Face

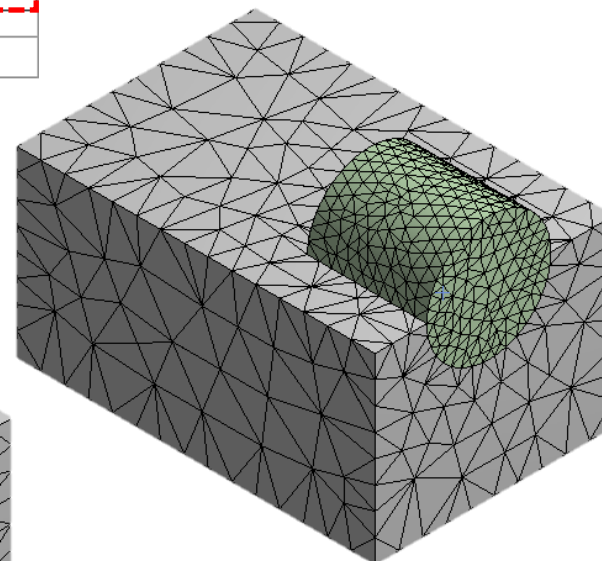

Body



Mesh – Ex.6

試繪製模型如圖所示，方塊長寬高分別為20mm、15mm、10mm，圓柱半徑4mm、深8mm，請以不同功能進行網格化練習(Method、Resolution、指定不同幾何之Sizing)

學習目標

- Add frozen
- Boolean
- Mesh-Method
- Mesh-Resolution
- Mesh-局部Sizing

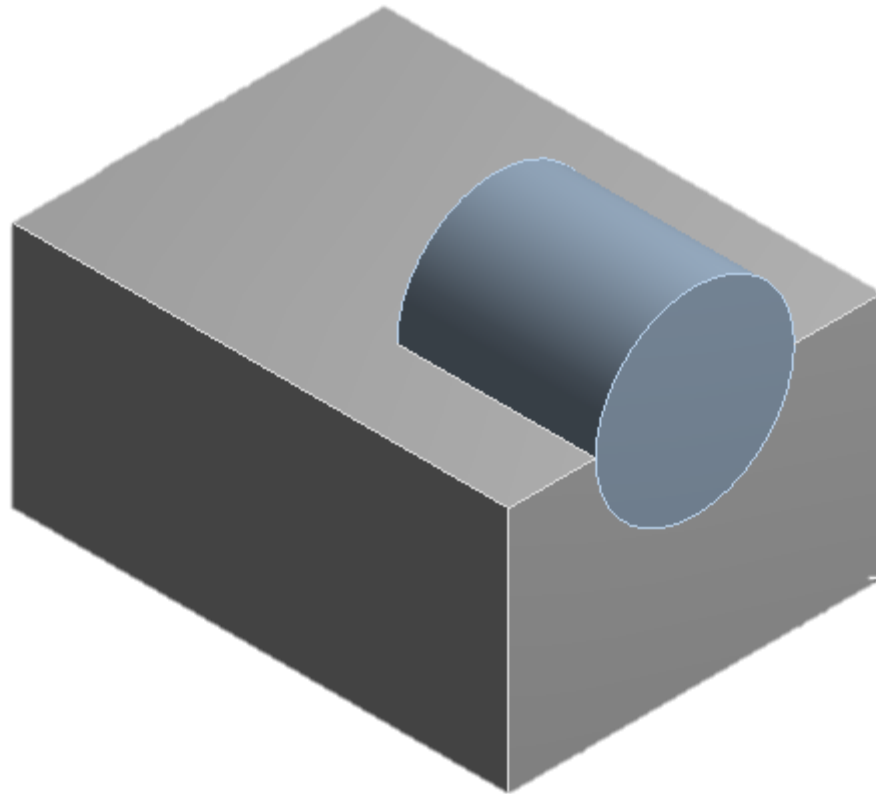



Mesh

- **元素的連續性**，相鄰元素需使用共同的節點和自由度
- 三角形和契形元素可被使用於過度區
- 元素需盡可能保持其原來的形狀，即不能扭曲太嚴重
- 在**施力處**的網格分割需良好
- 在**預期應力集中處**如孔洞、凹槽等處的分割，元素尺寸需較小且分佈良好
- 網格的分割的密度需盡可能隨應力分佈而調整

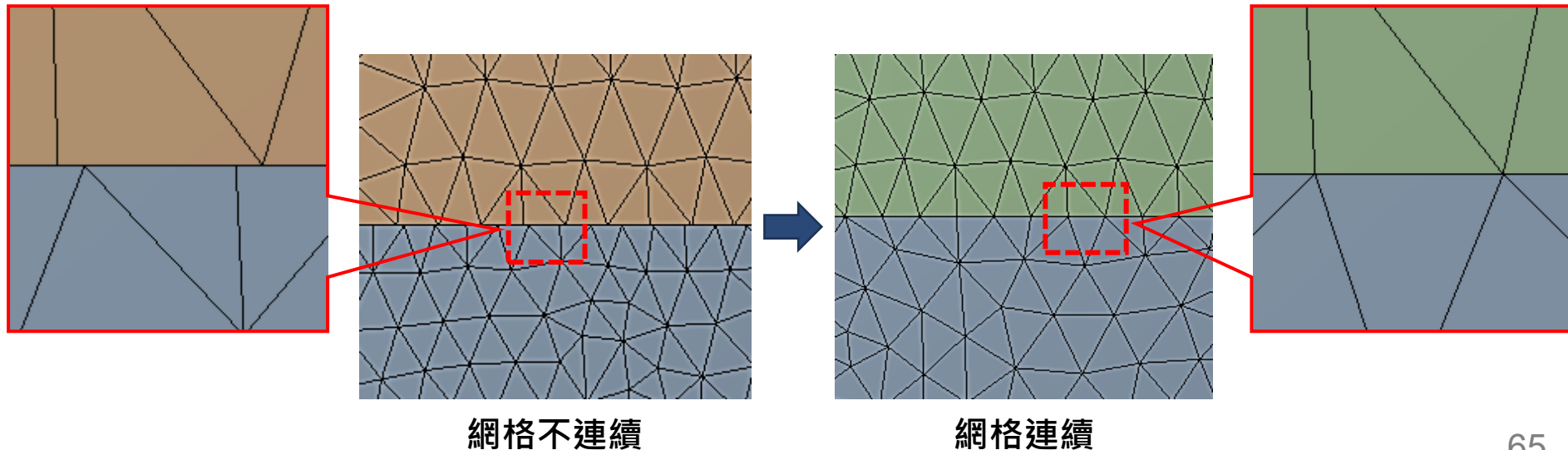

Introduction of ANSYS Workbench

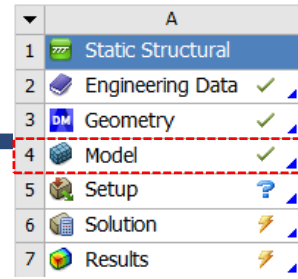

■ 局部網格處理

➤ Sizing

- ✓ Sphere of influence (Pinball)

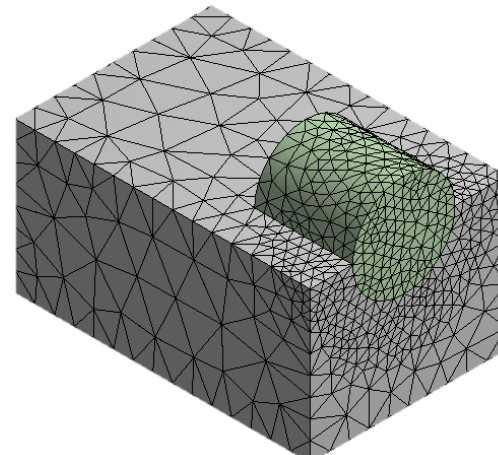
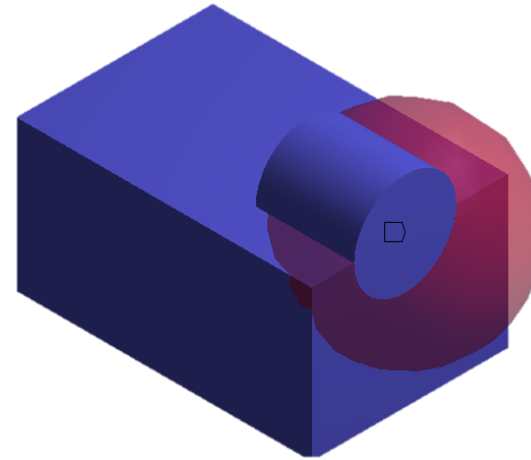
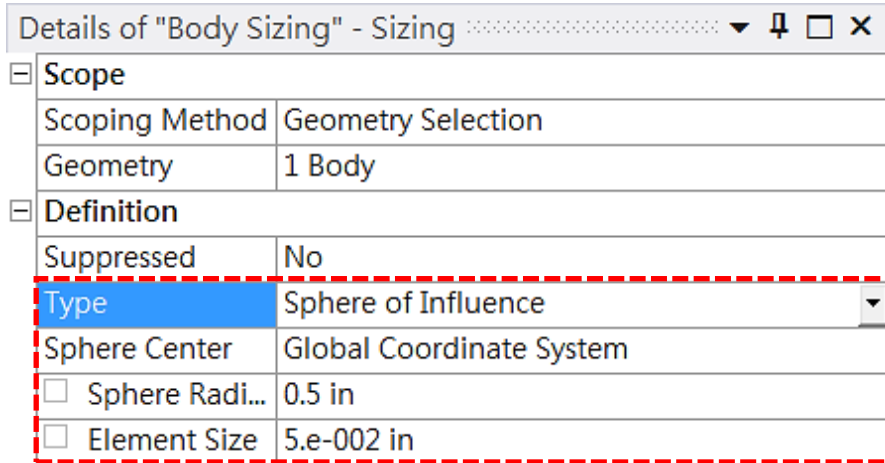

Mesh – Ex.7 (來源：ANSYS Workbench有限元分析從入門到精通)



請依下列實體模型(pipe.agdb)進行不同功能之網格化練習

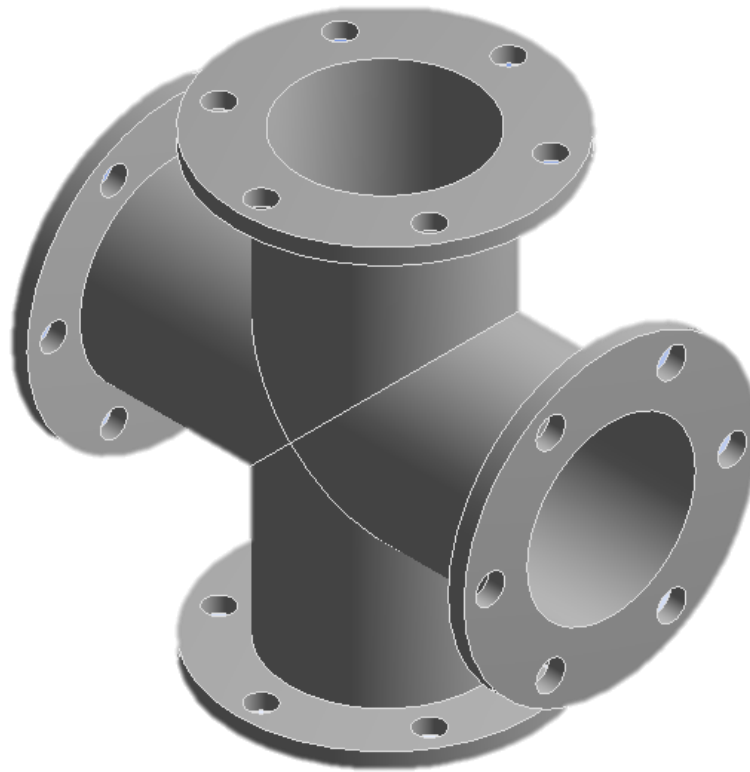

Mesh – Ex.7

學習目標

- Mesh-Division
- Mesh-Refinement
- Mesh-Pinball
- 剖面觀察

■ 局部網格A

➤ Sizing

- ✓ Number of division

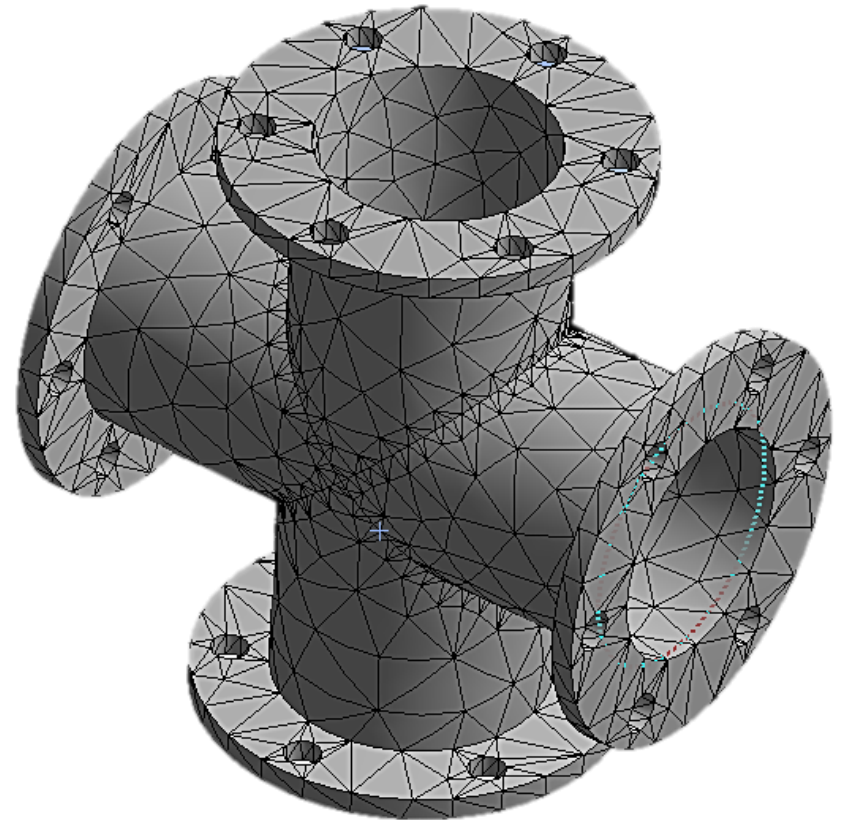
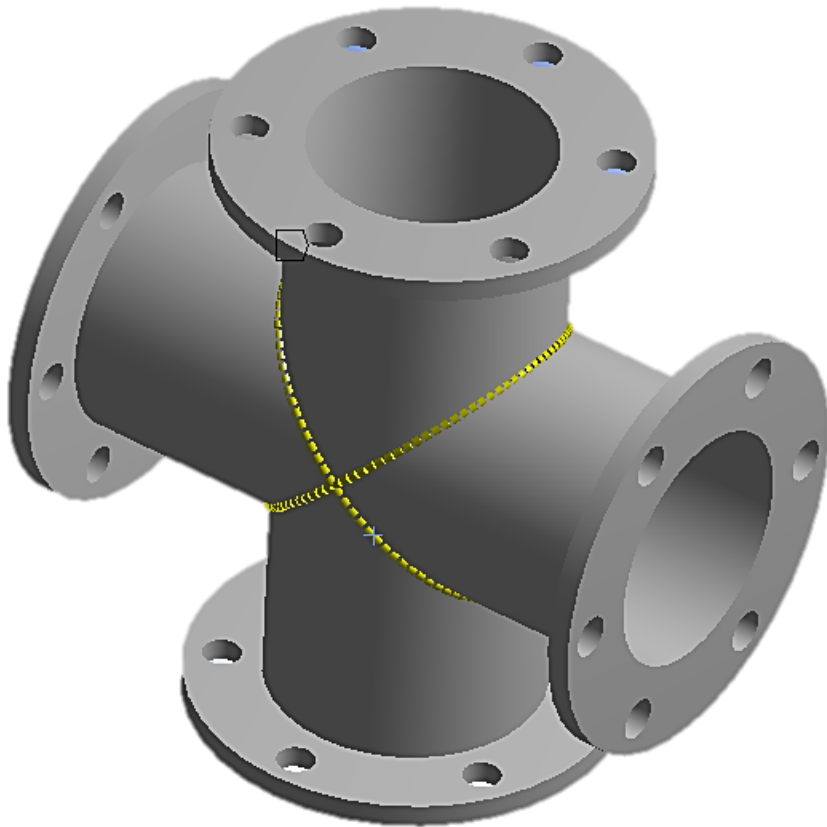

Mesh – Ex.7

學習目標

- Mesh-Division
- Mesh-Refinement
- Mesh-Pinball
- 剖面觀察

■ 局部網格B

➤ Refinement

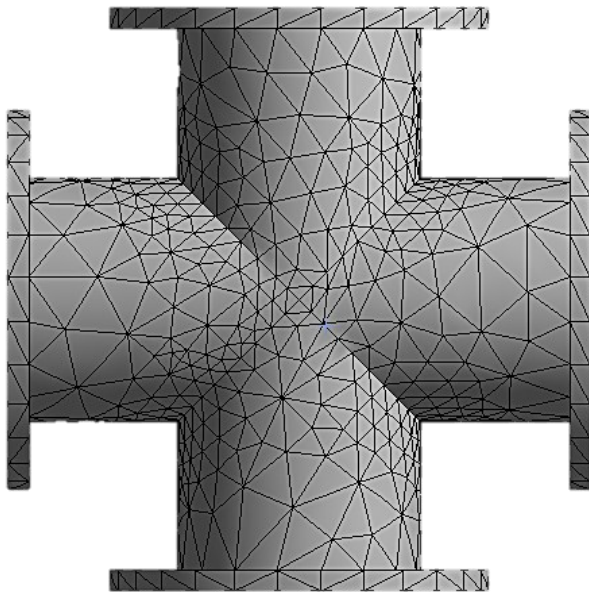

Refinement = 1

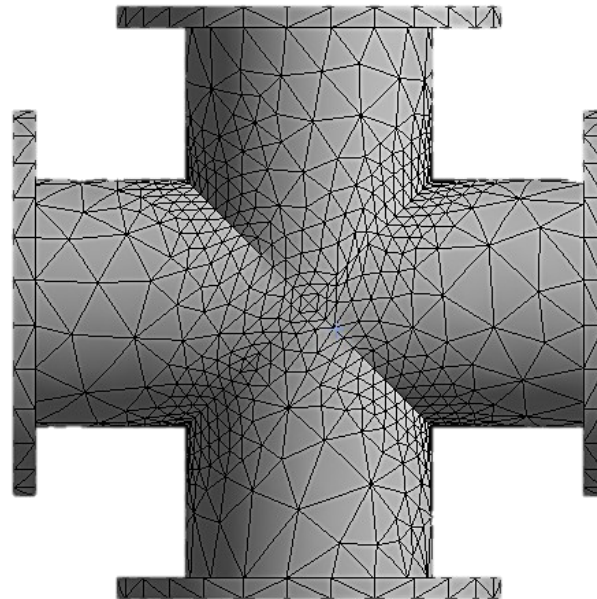

Refinement = 2

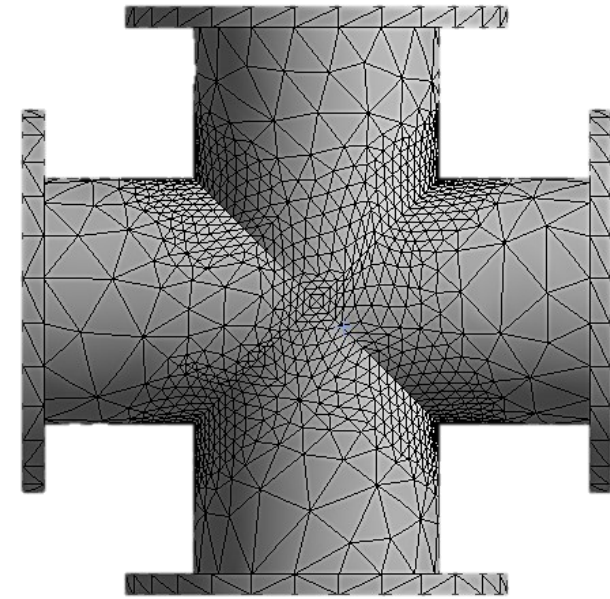

Refinement = 3

Mesh – Ex.7

學習目標

- Mesh-Division
- Mesh-Refinement
- Mesh-Pinball
- 剖面觀察

■ 局部網格C

➤ Sizing

- ✓ Sphere of influence (Pinball)

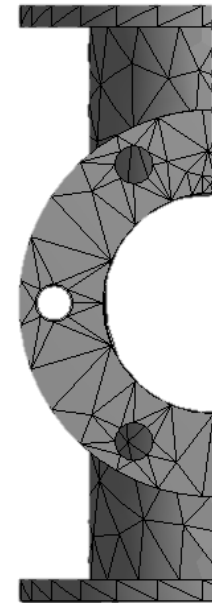
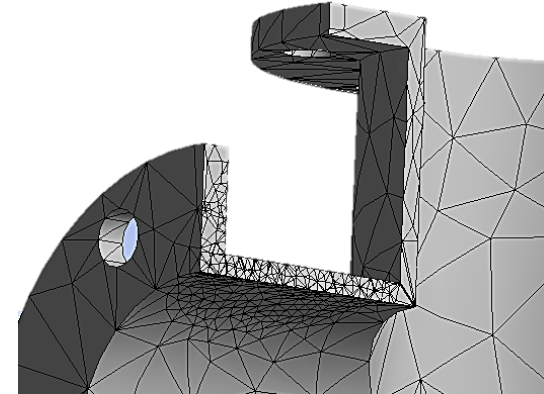
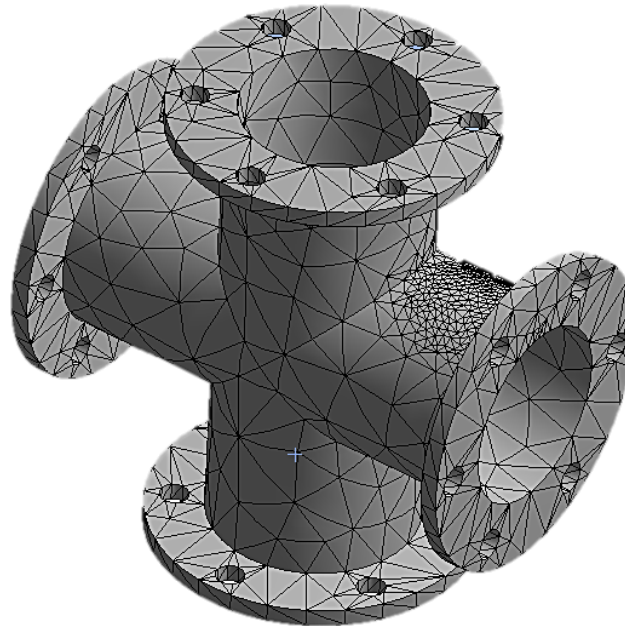
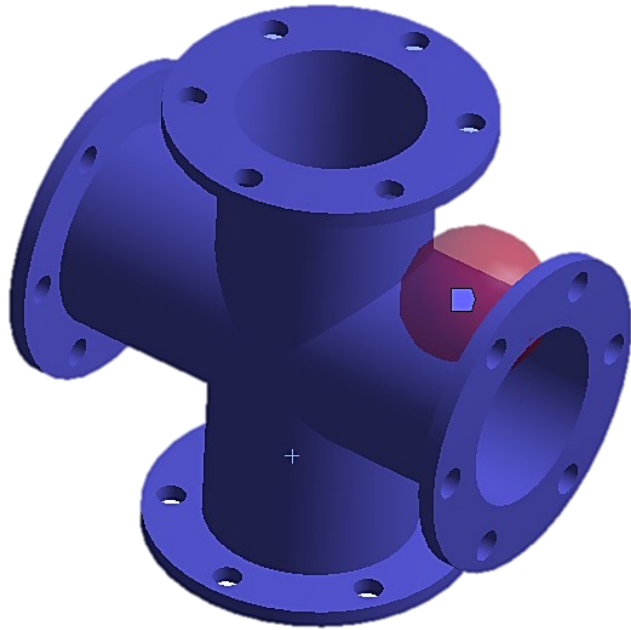



Introduction of ANSYS Workbench

■ 複雜網格設定→查HELP

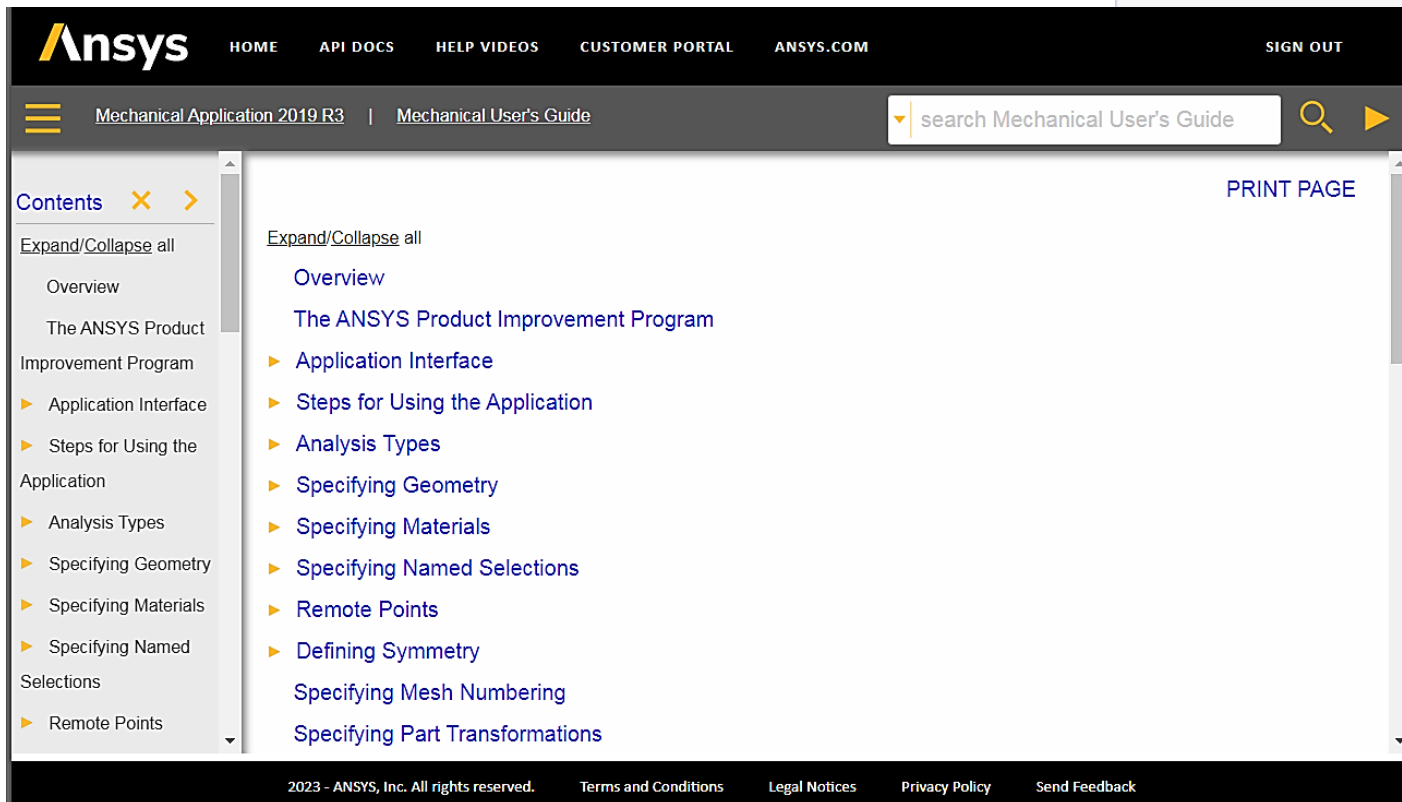
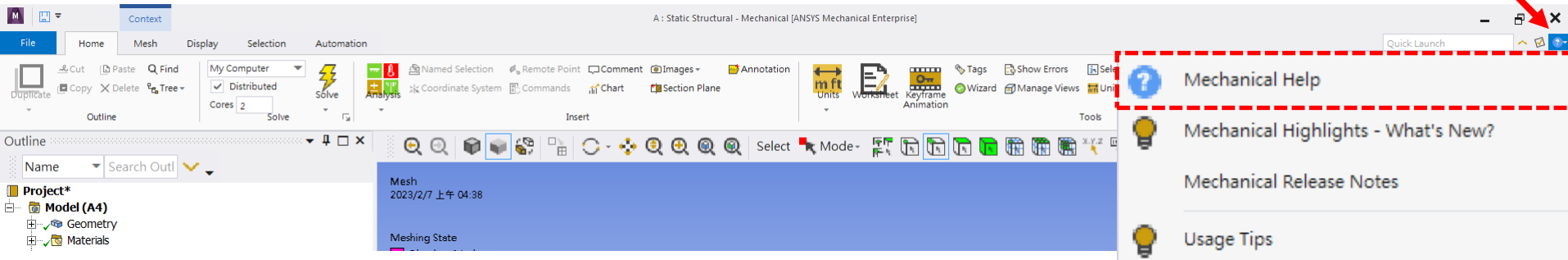

Introduction of ANSYS Workbench

A	
1	Static Structural
2	Engineering Data ✓
3	DM Geometry ✓
4	Model ✓
5	Setup ?
6	Solution ⚡
7	Results ⚡

■ 後處理(Post-processing)

➤ 結果顯示方式

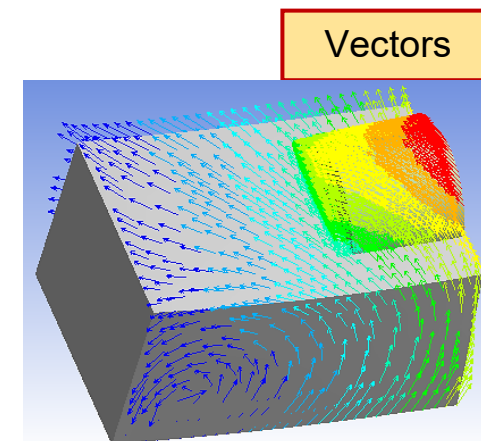
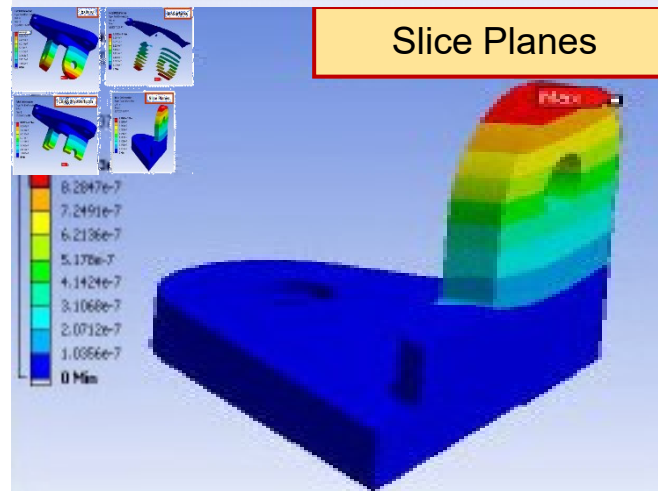
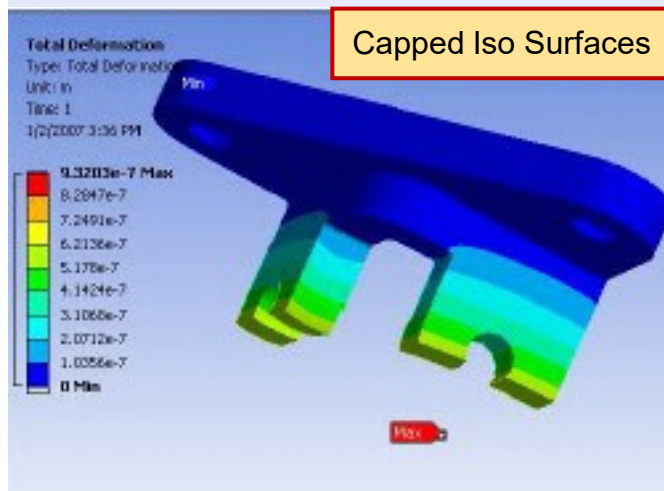
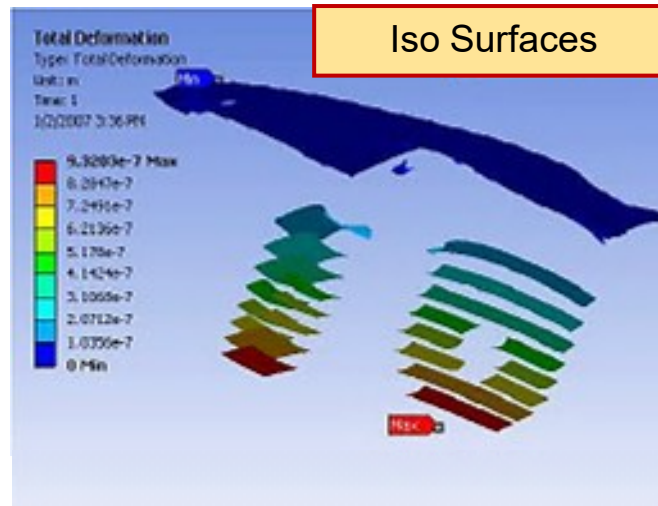
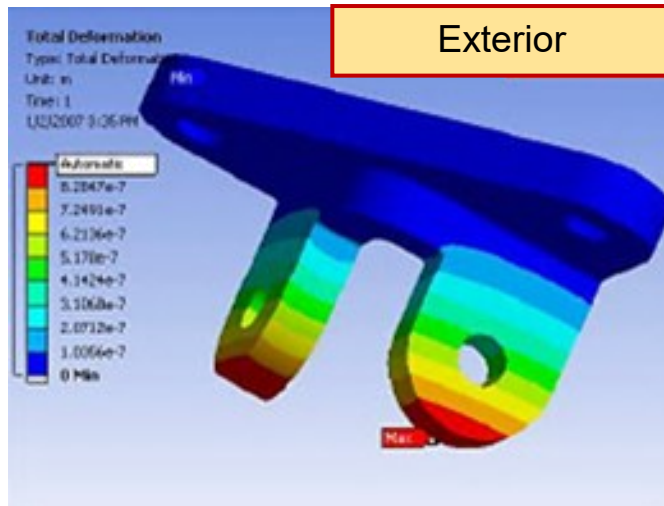

Introduction of ANSYS Workbench

A	
1	Static Structural
2	Engineering Data ✓
3	DM Geometry ✓
4	Model ✓
5	Setup ?
6	Solution ⚡
7	Results ⚡

■ 後處理(Post-processing)

➤ Capped ISO surface

- ✓ 可設定閾值以外區域之圖案不顯示

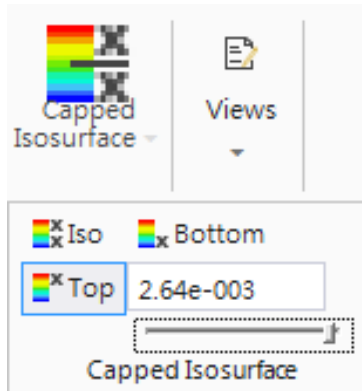

Top capped : 超過閾值區域不顯示
Bottom capped : 低於閾值區域不顯示

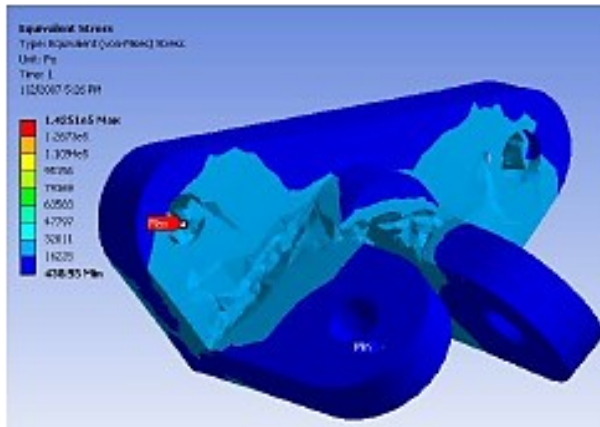

頂部封頂等值面

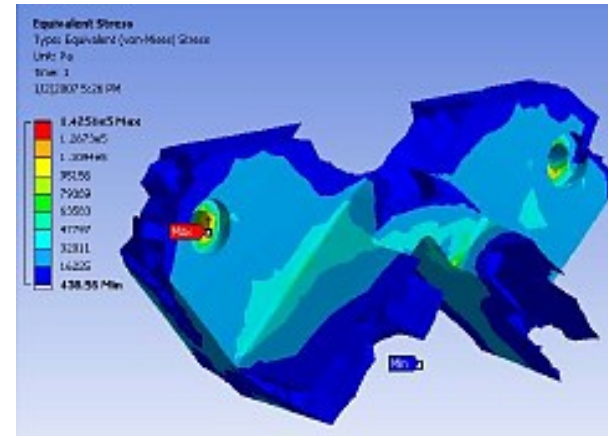

底部封頂等值面

Introduction of ANSYS Workbench

■ 後處理(Post-processing)

➤ 多觀察視窗

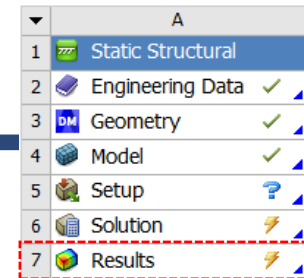

The screenshot displays the ANSYS Workbench interface for a static structural analysis. The 'Results' tab is active, and the 'Display' button in the top right corner is highlighted with a red dashed box. The interface is divided into several panels:

- Outline:** Shows the project hierarchy, including Model (A4), Static Structural (A5), and Solution (A6). The 'Total Deformation' result is selected.
- Mesh:** Displays the finite element mesh of the part.
- Total Deformation:** Shows the total deformation of the part. The maximum deformation is 0.0026374 mm.
- Force:** Shows the applied force of 10 N.
- Equivalent Stress:** Shows the equivalent stress distribution on the part. The maximum stress is 5.0238 MPa.
- Details of "Total Deformation":** A table showing the scope and definition of the result.
- Graph:** A graph showing the time history of the result.
- Tabular Data:** A table showing the time history of the result.

Time [s]	Minimum [mm]	Maximum [mm]	Average [mm]
1.	0.	2.6374e-003	3.672e-004



3D Solution – Ex.8 (來源：成功大學李輝煌教授)

機翼模型，尺寸如下所示，使用MultiZone之網格方法將翼板頂面、腹板側面、接合處圓角面進行mesh設定，並將翼板與腹板接合處之圓角兩面設定element size為7的mesh。邊界條件如圖所示，板子後方之面固定，上方施予頂面一力。觀察其等效應力、位移量變化、結構誤差及Safety Factor。材料選用鋼。(單位：MM, N)

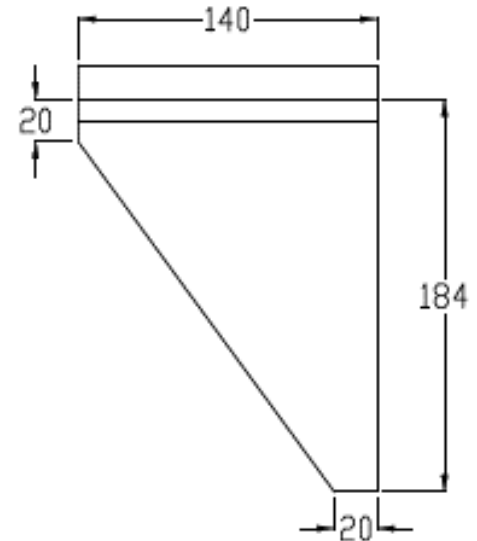
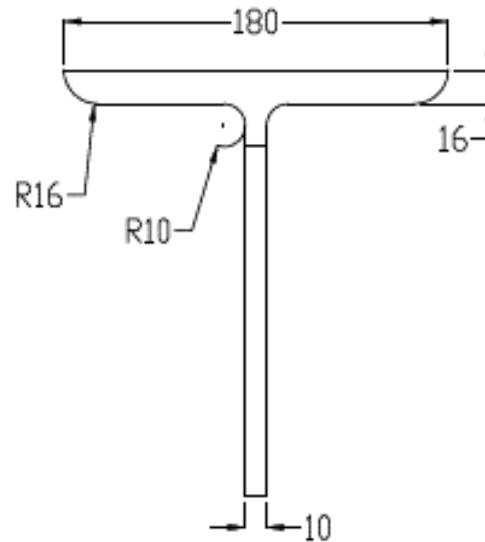
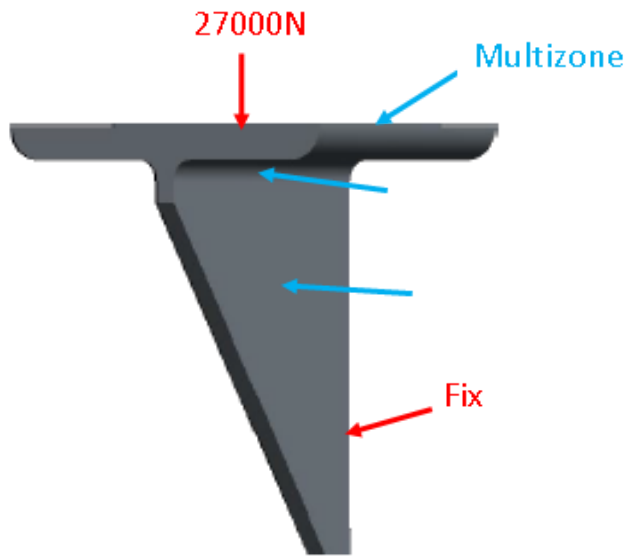

3D Solution – Ex.8

學習目標

- Blend
- Mesh-MultiZone
- 後處理顯示

機翼模型，尺寸如下所示，使用MultiZone之網格方法將翼板頂面、腹板側面、接合處圓角面進行mesh設定，並將翼板與腹板接合處之圓角兩面設定element size為7的mesh。邊界條件如圖所示，板子後方之面固定，上方施予頂面一力。觀察其等效應力、位移量變化、結構誤差及Safety Factor。材料選用鋼。(單位：MM, N)

多視窗顯示

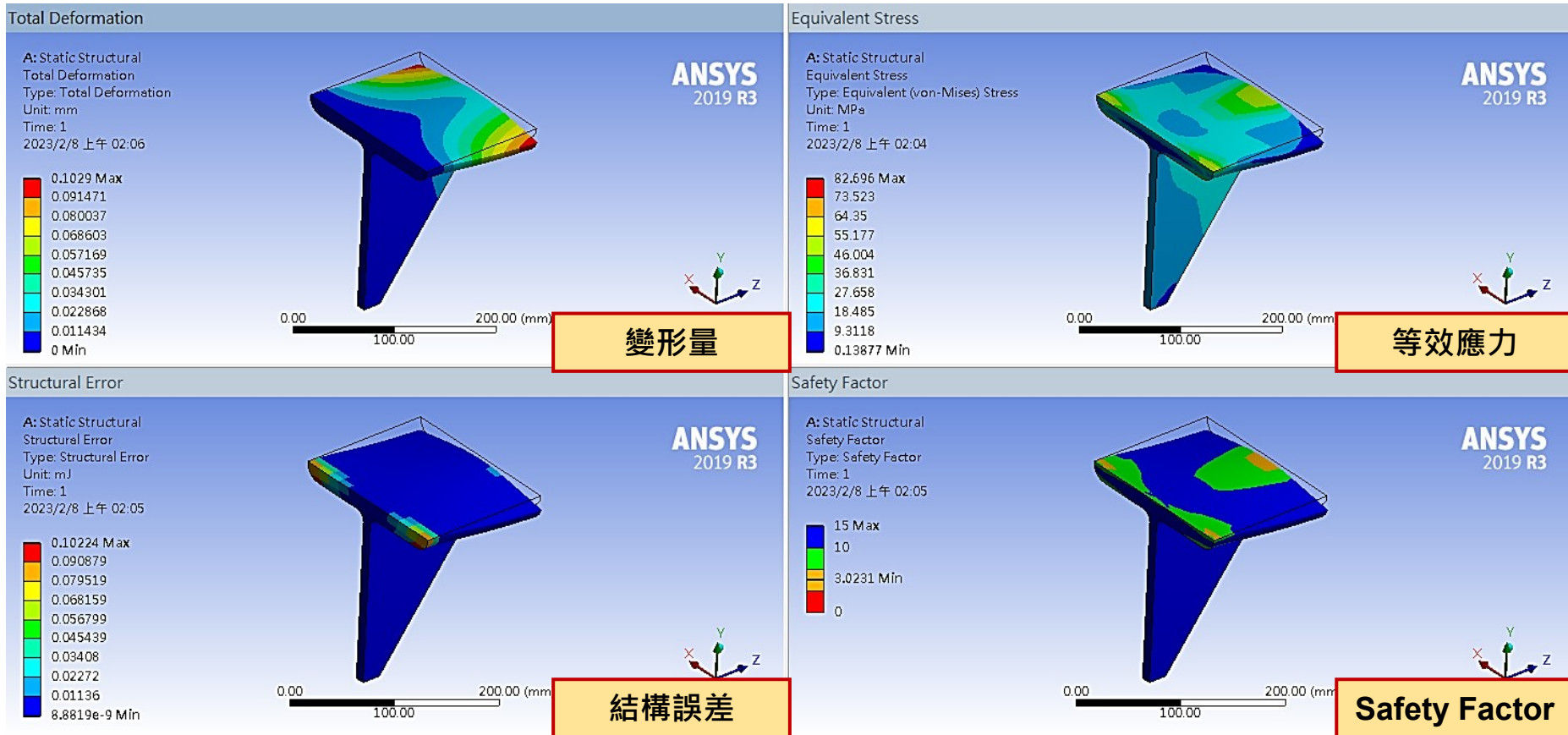

3D Solution – Ex.8

學習目標

- Blend
- Mesh-*MultiZone*
- 後處理顯示

機翼模型，尺寸如下所示，使用MultiZone之網格方法將翼板頂面、腹板側面、接合處圓角面進行mesh設定，並將翼板與腹板接合處之圓角兩面設定element size為7的mesh。邊界條件如圖所示，板子後方之面固定，上方施予頂面一力。觀察其等效應力、位移量變化、結構誤差及Safety Factor。材料選用鋼。(單位：MM, N)

動畫顯示

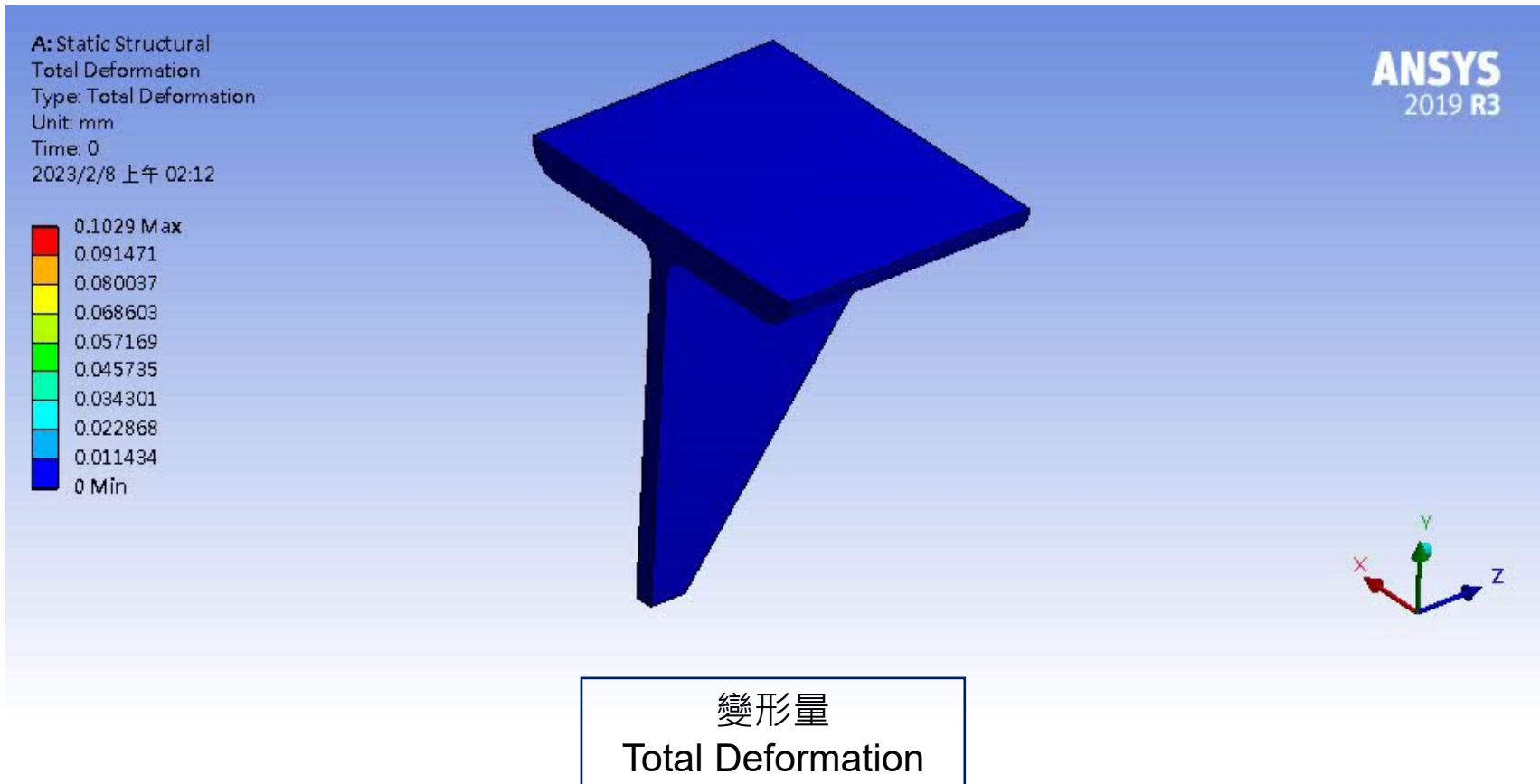



Convergence

- 隨著網格密度增加(即元素增加、mesh尺寸減小)，有限元素分析所求出的解會趨近於一個定值，即為該題目的正確解(exact solution)，但隨著網格變得更精細，所消耗的運算資源也會增加
- 收斂性分析：當進一步細分網格後所求得的解變化很小時，即可認為網格已經收斂了
- 收斂物理量通常可為應力/位移/能量，誤差最好於5%內

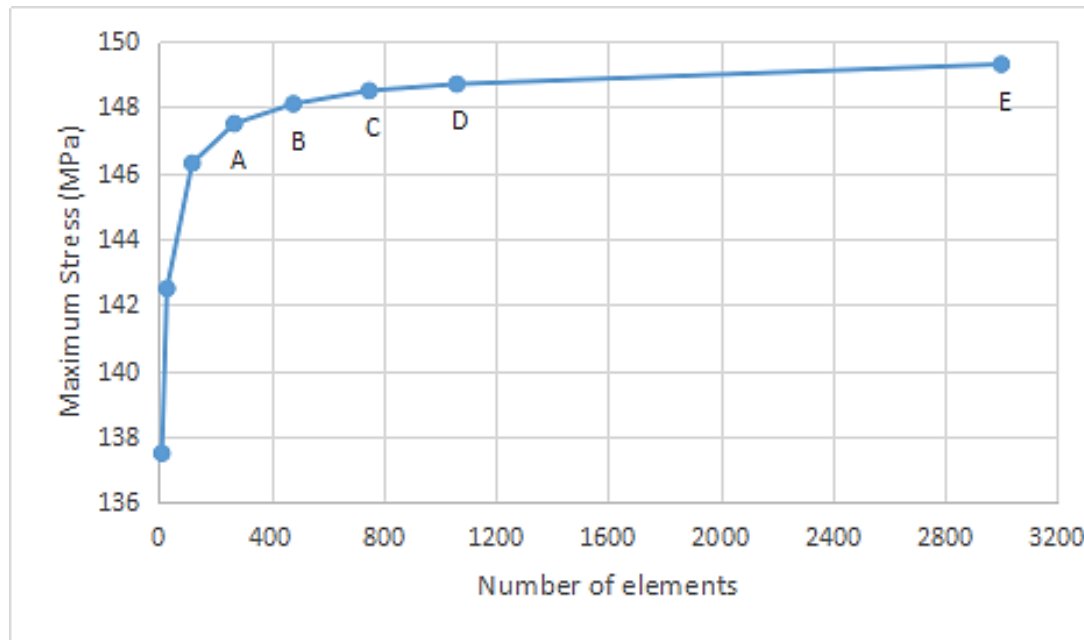

Convergence



圓角處Mesh元素大小

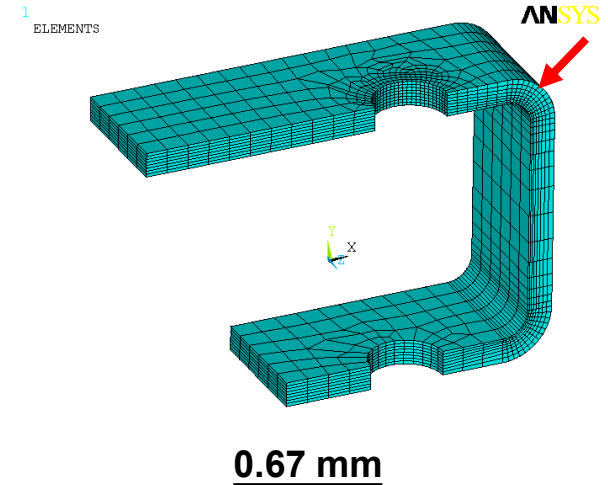
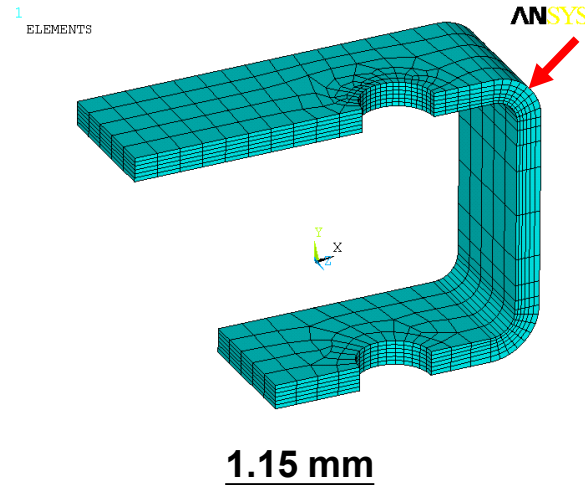
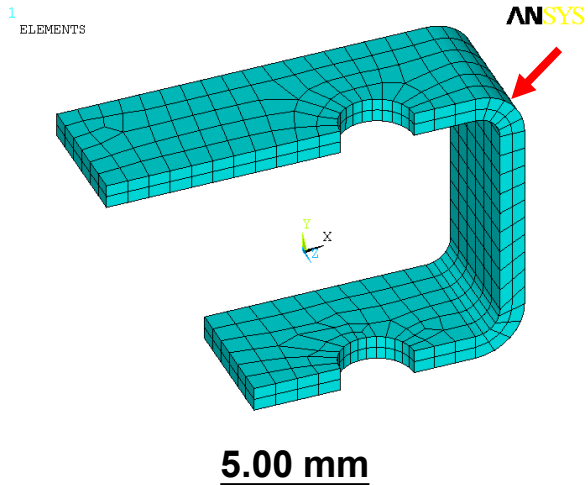

圓角處最大等效應力值

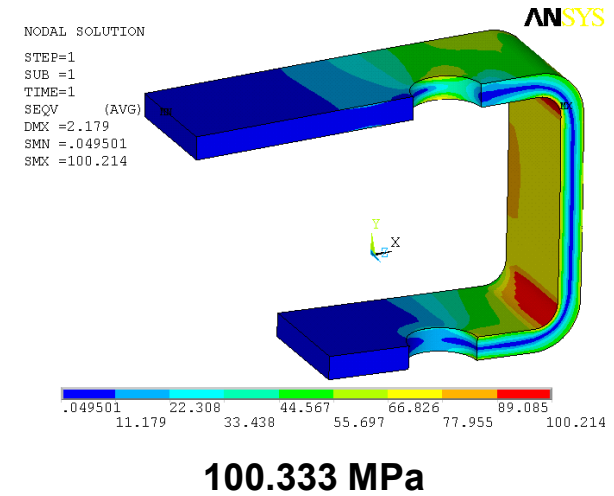
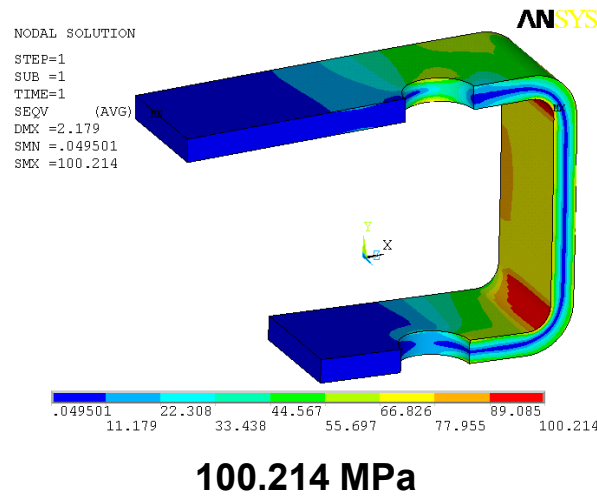
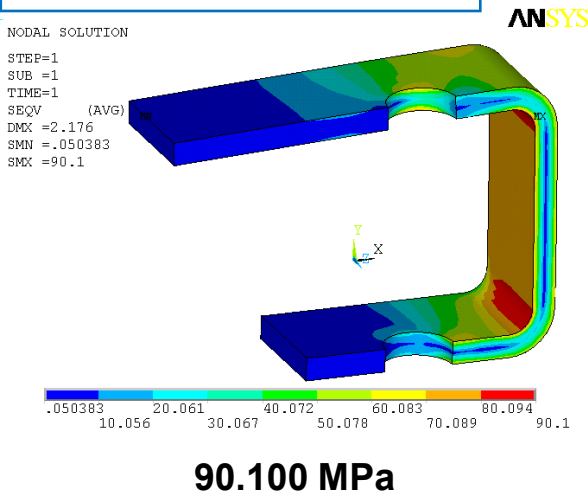

模型收斂

11.2%

0.12%



Convergence – Ex.9 (來源：成功大學李輝煌教授)

一材料為鋼(steel)製成之懸臂樑，尺寸為100x10x10mm，上端平面施以1MPa均佈負載，請應用不同元素大小(element size)探討懸臂樑模型之收斂性(1)Hex mesh、(2)Tet mesh

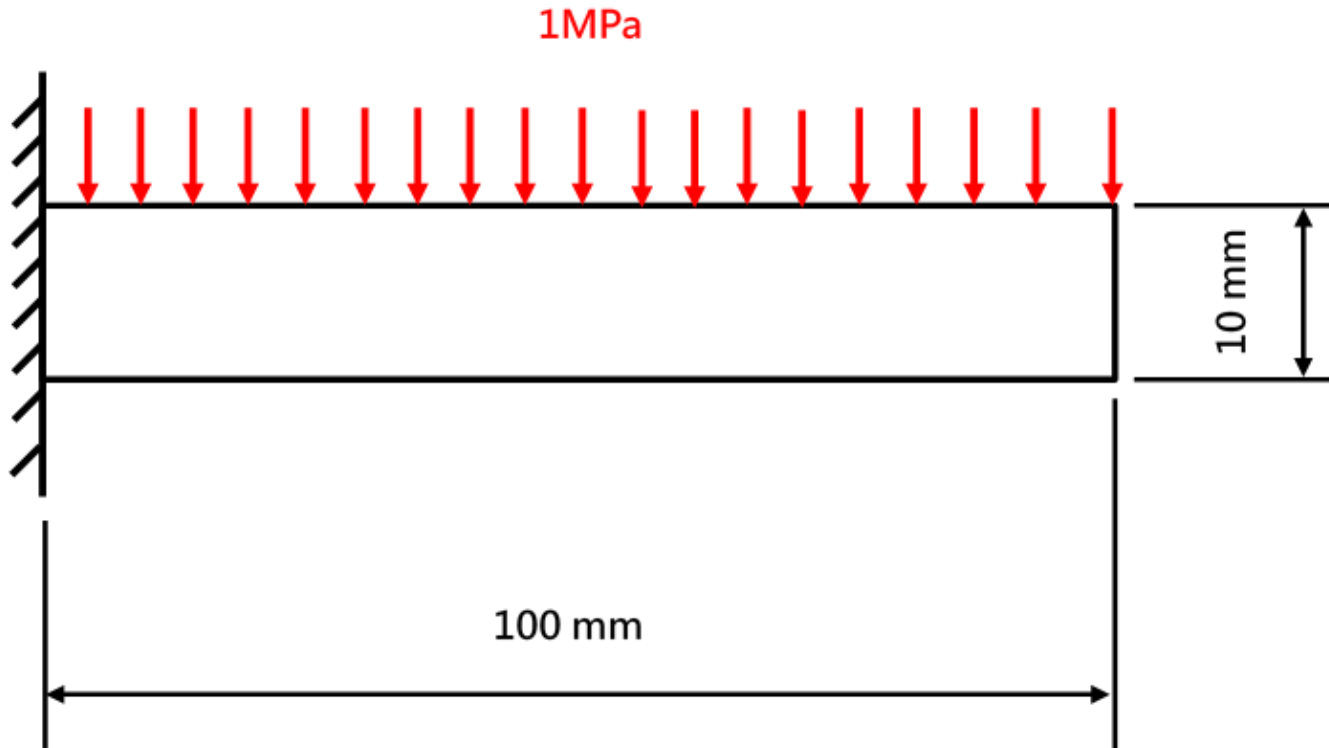

Convergence – Ex.9

一材料為鋼(steel)製成之懸臂樑，尺寸為100x10x10mm，上端平面施以1MPa均佈負載，請應用不同元素大小(element size)探討懸臂樑模型之收斂性(1)Hex mesh、(2)Tet mesh

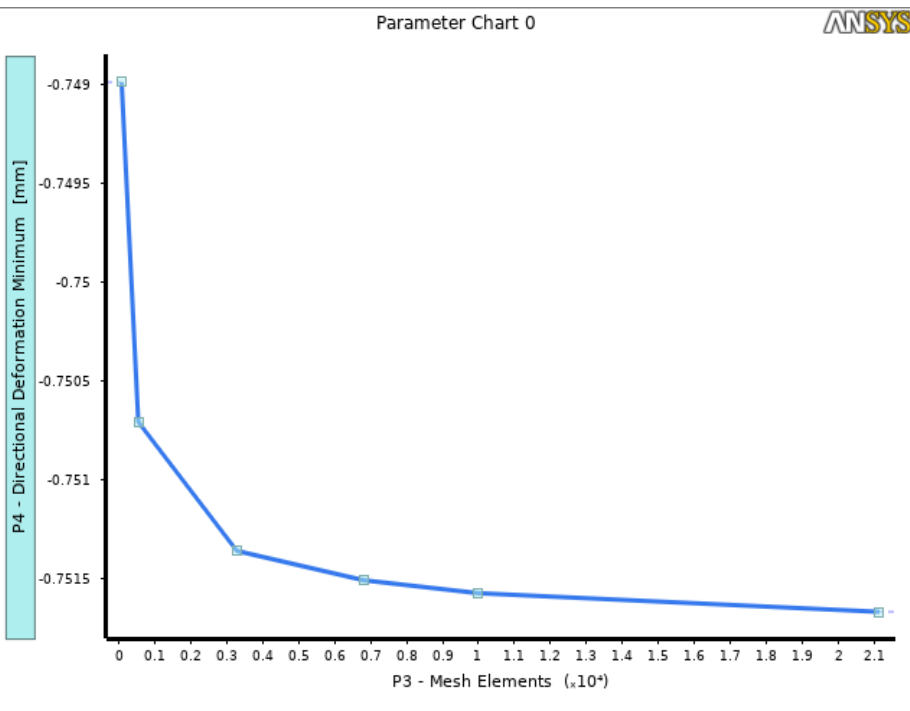
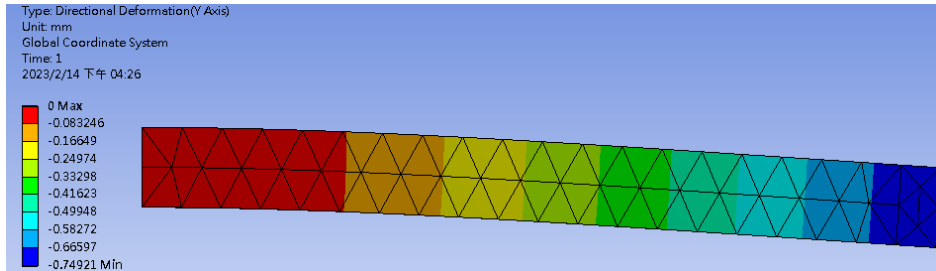
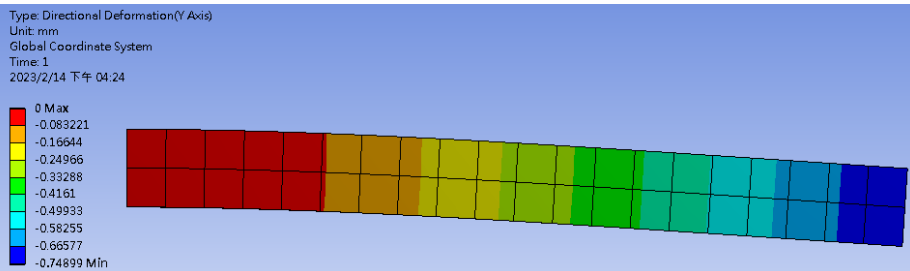

Hex mesh

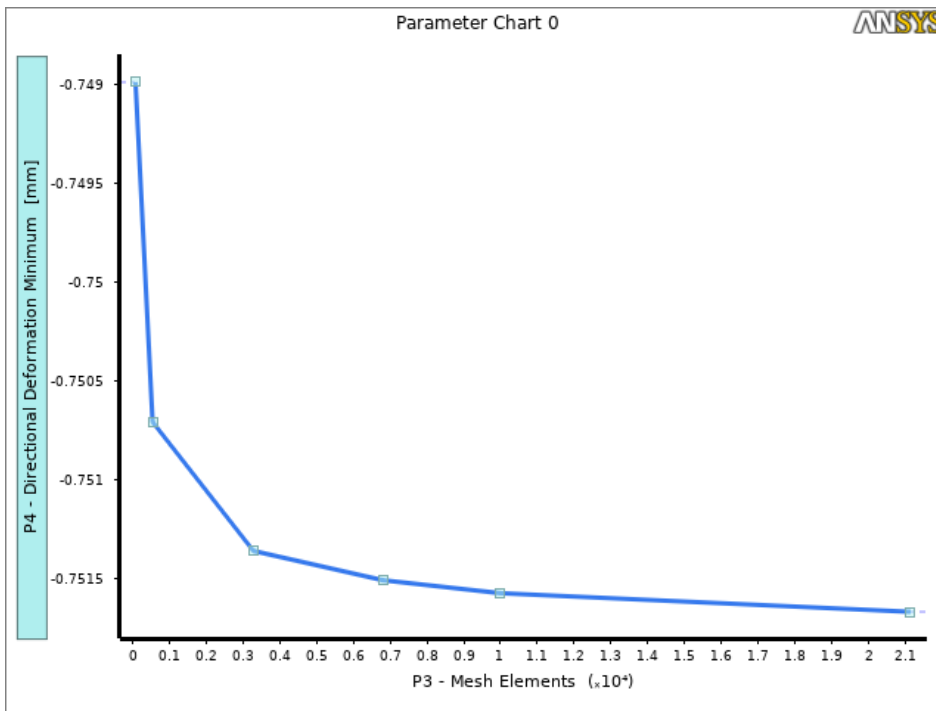

Tet mesh