

# Computer Aided Engineering

## -Part 1 ANSYS-2

電腦輔助工程分析

## -Part 1 ANSYS-2



---

林峻立 特聘教授

Chun-Li Lin, Ph.D.

國立陽明交通大學 生物醫學工程系

Department of Biomedical Engineering,  
National Yang Ming Chiao Tung University.

# Introduction of ANSYS-3D modeling

## ■ Utility Menu

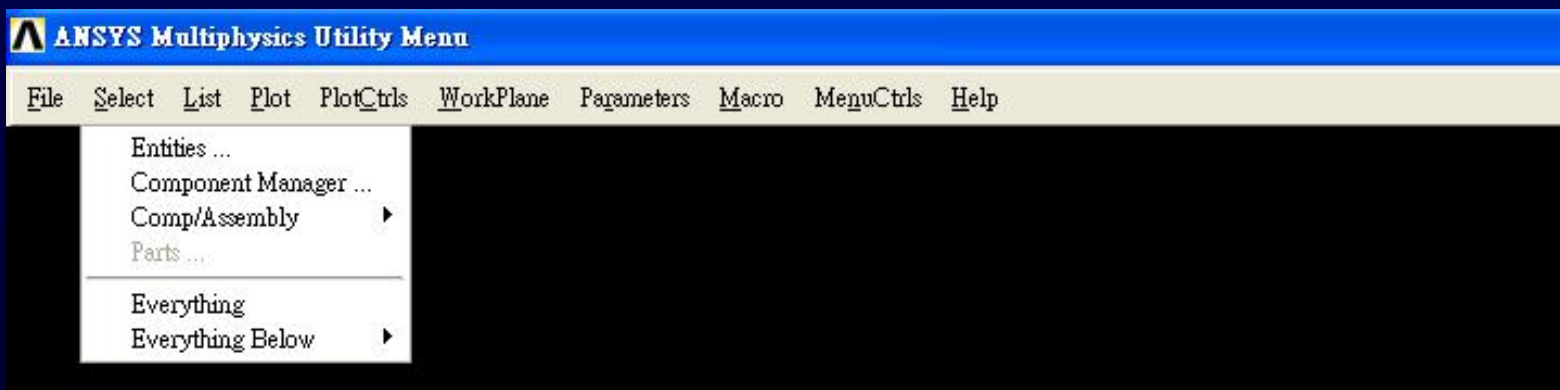
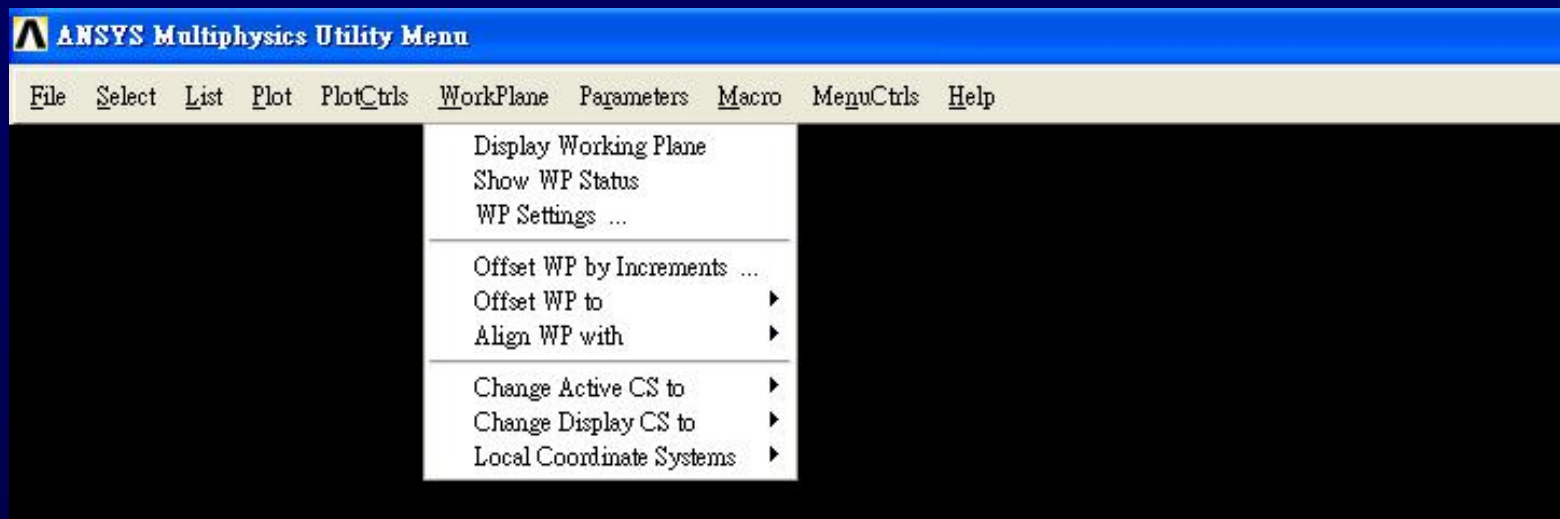

# Introduction of ANSYS

## ■ Utility Menu>WorkPlane

### ■ Offset by increments

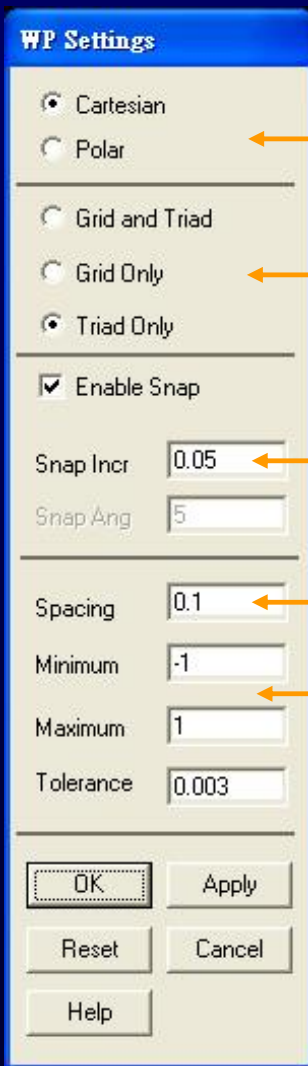

座標系統

網格形式

工作平面座標移動量

工作平面網格大小

工作平面範圍

# 3D – modeling: (Ex 5)

## ■ Construct 3D solid model

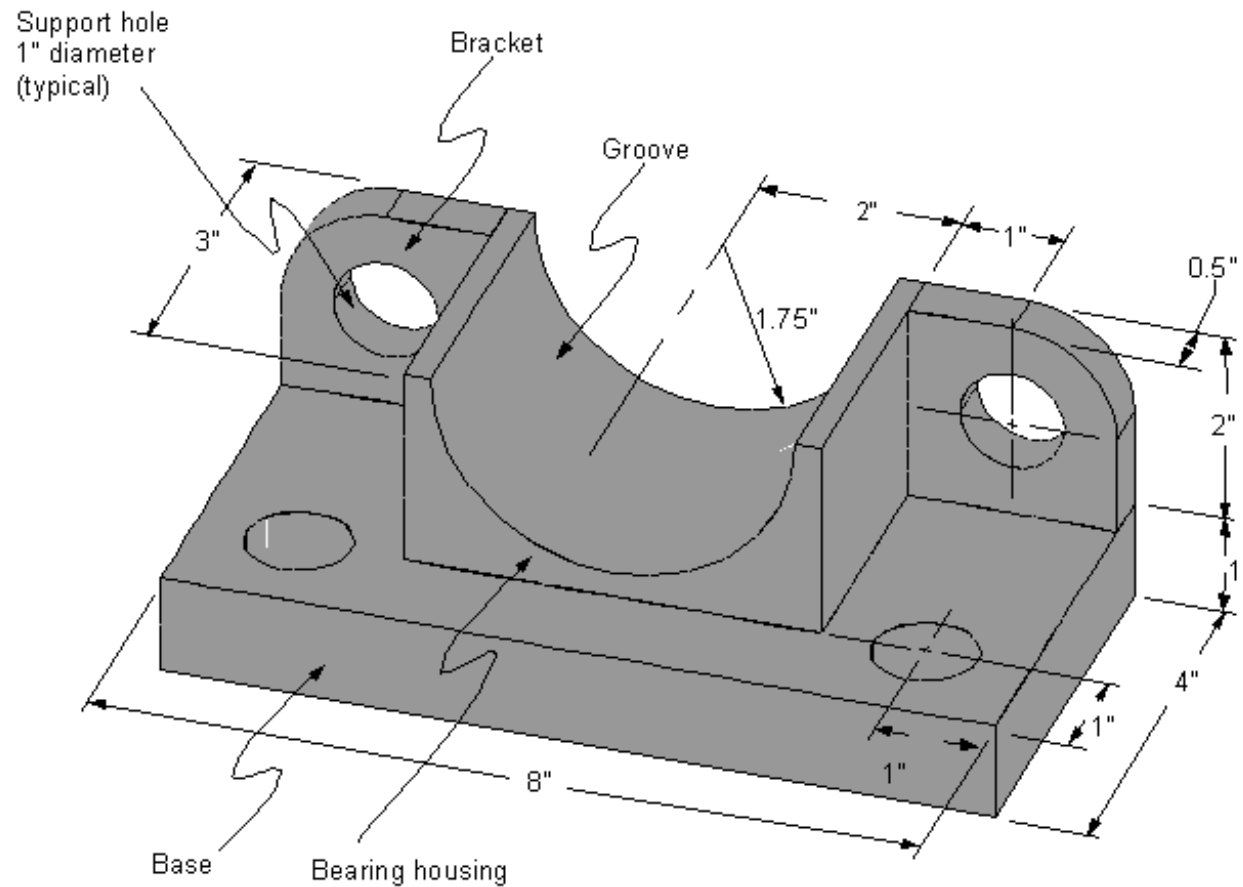

Solid Model

# Introduction of ANSYS

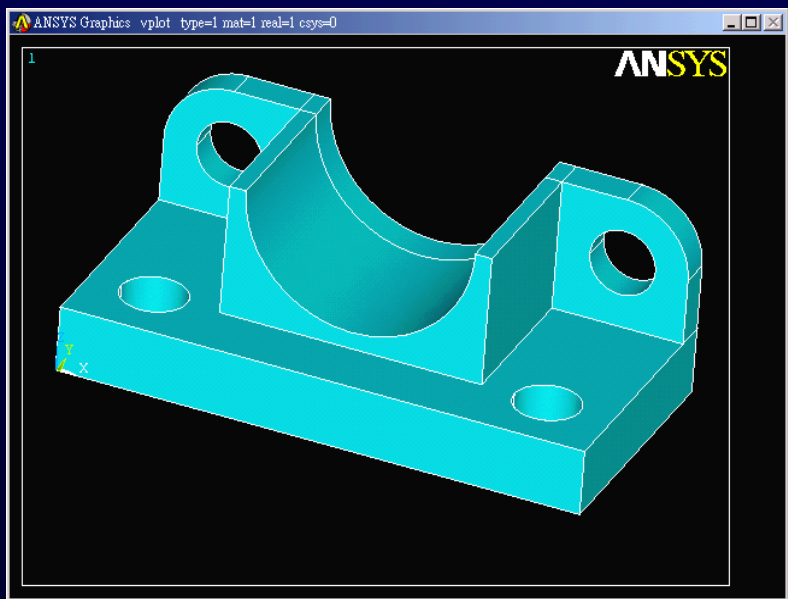
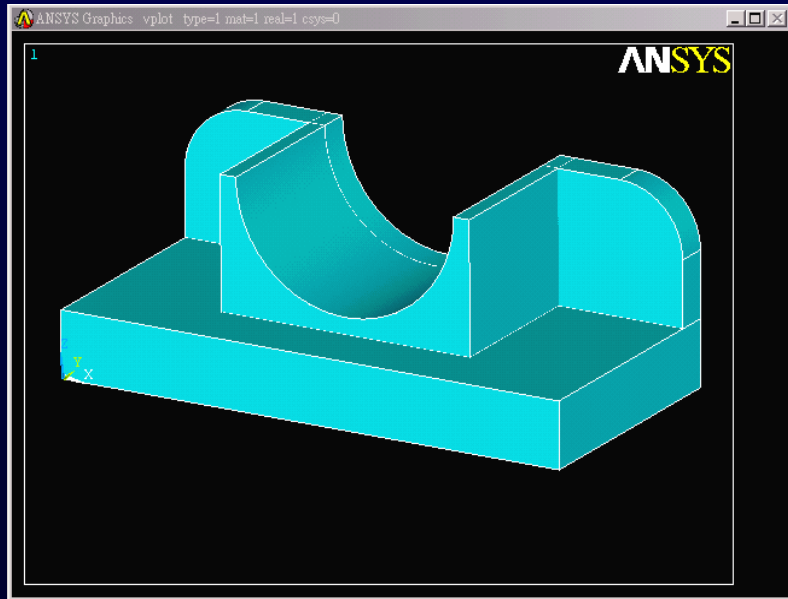
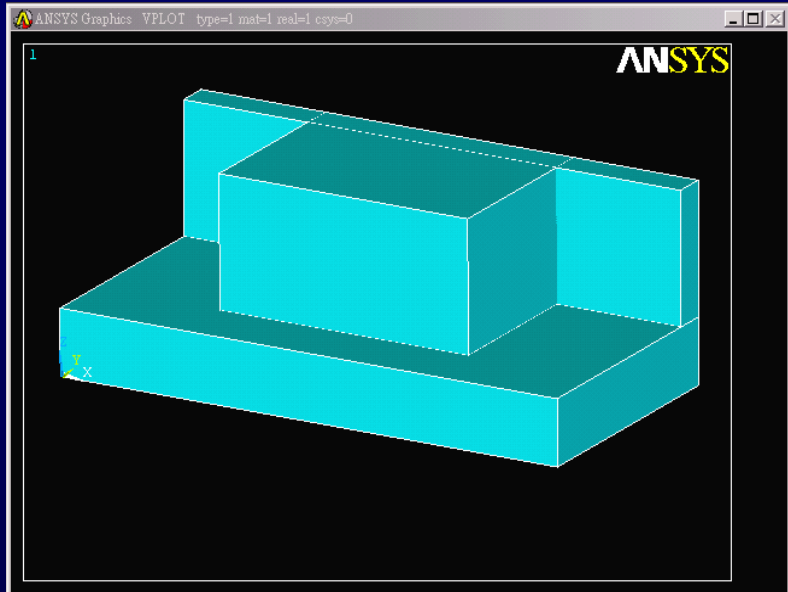
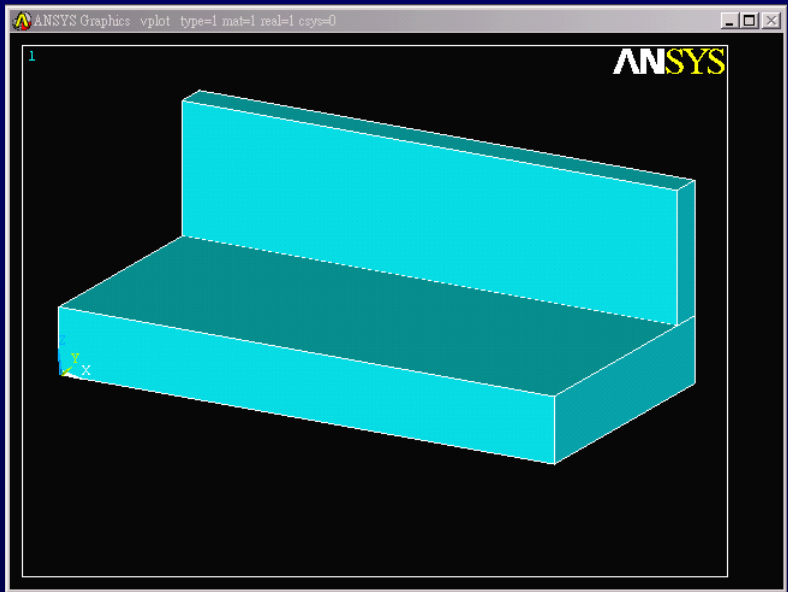

# Introduction of ANSYS

- Preprocessor>Create>Volumes>Block>By Dimension

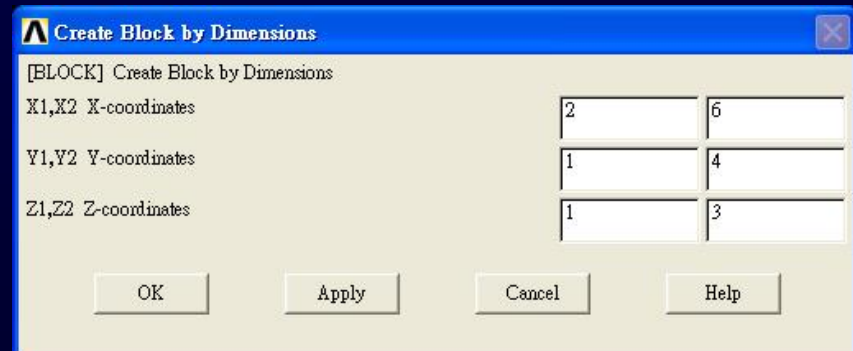
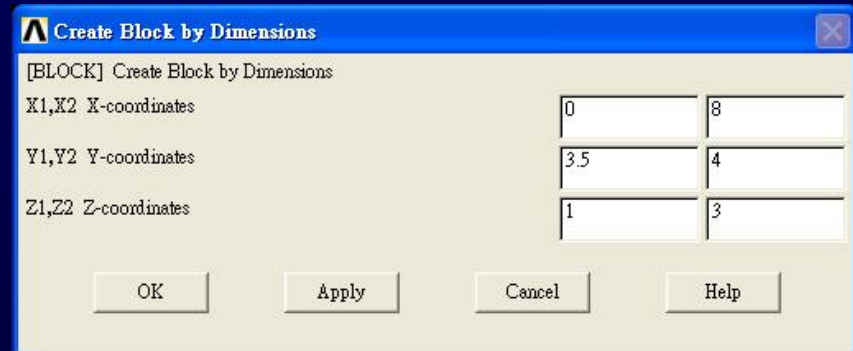
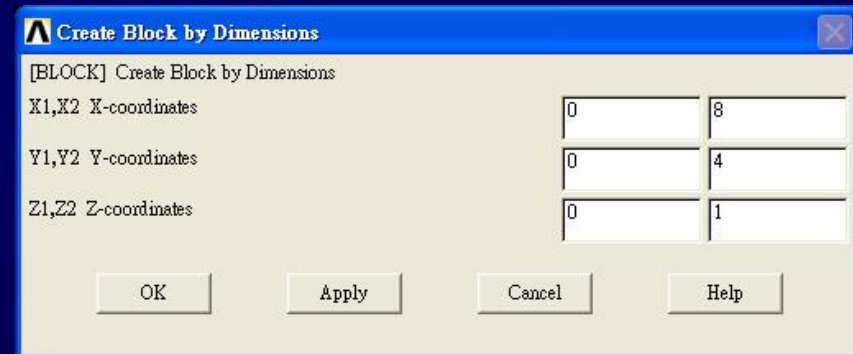
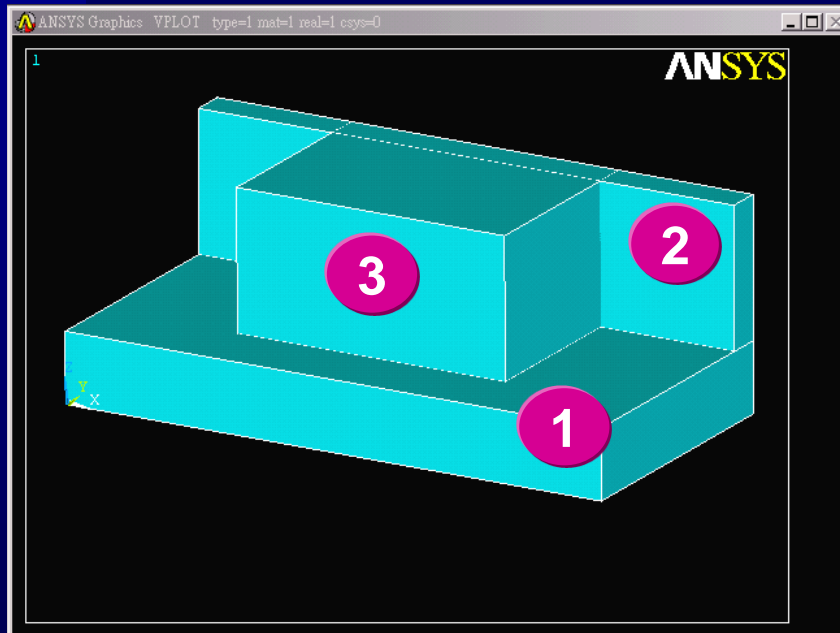

# Introduction of ANSYS

- Utility Menu > WorkPlane > Display WorkPlane
- Utility Menu > WorkPlane > WP Settings
- Utility Menu > WorkPlane > Offset WP by Increments

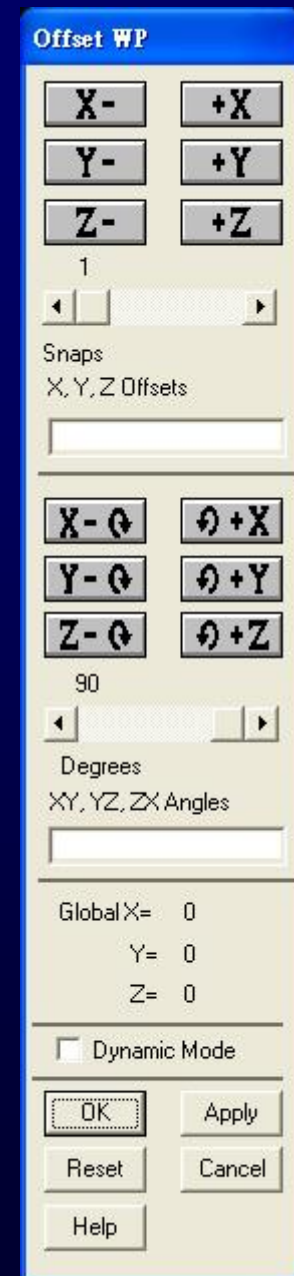
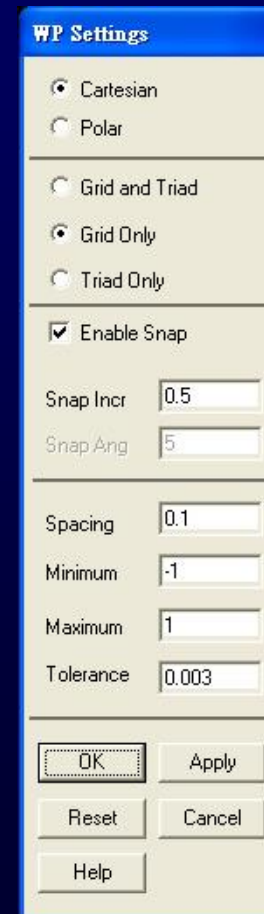
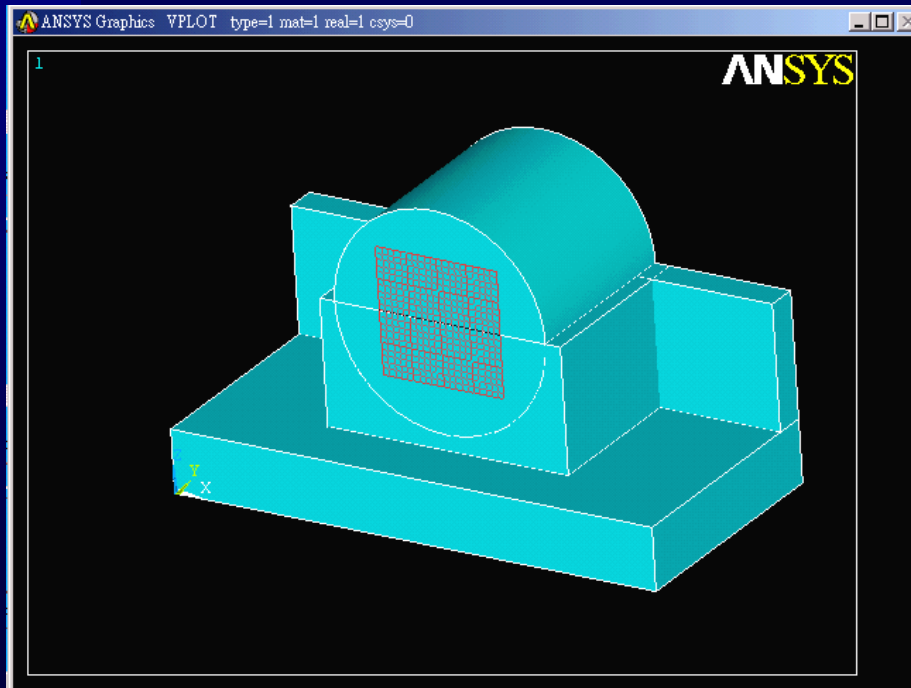

# Introduction of ANSYS

- Preprocessor>Create>Volumes>Solid Cylinder

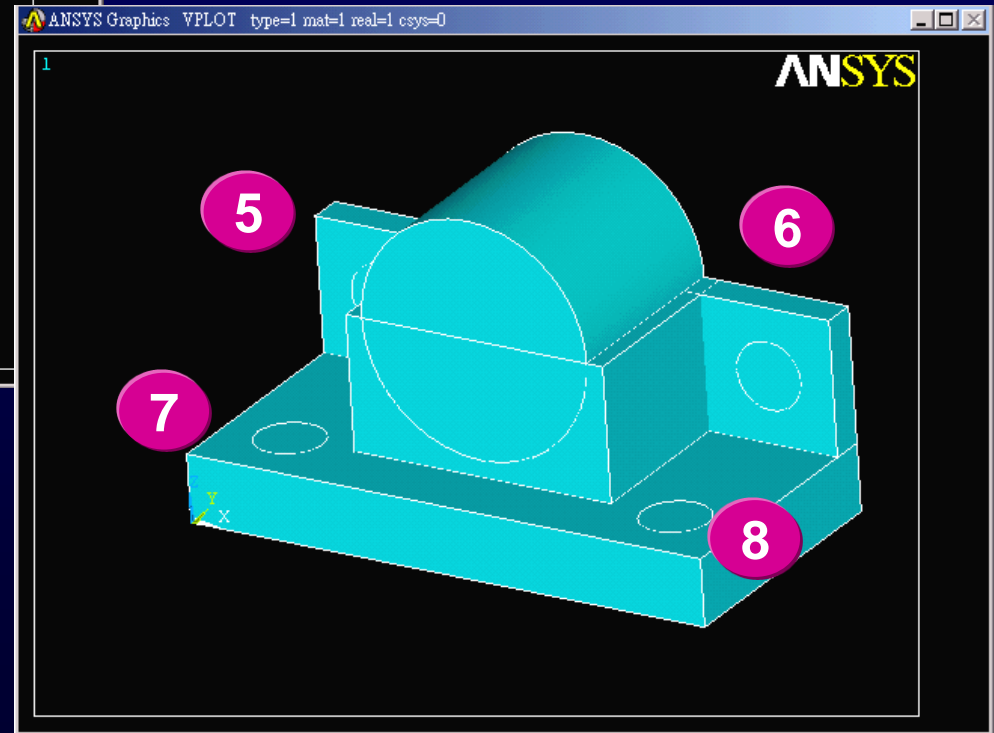
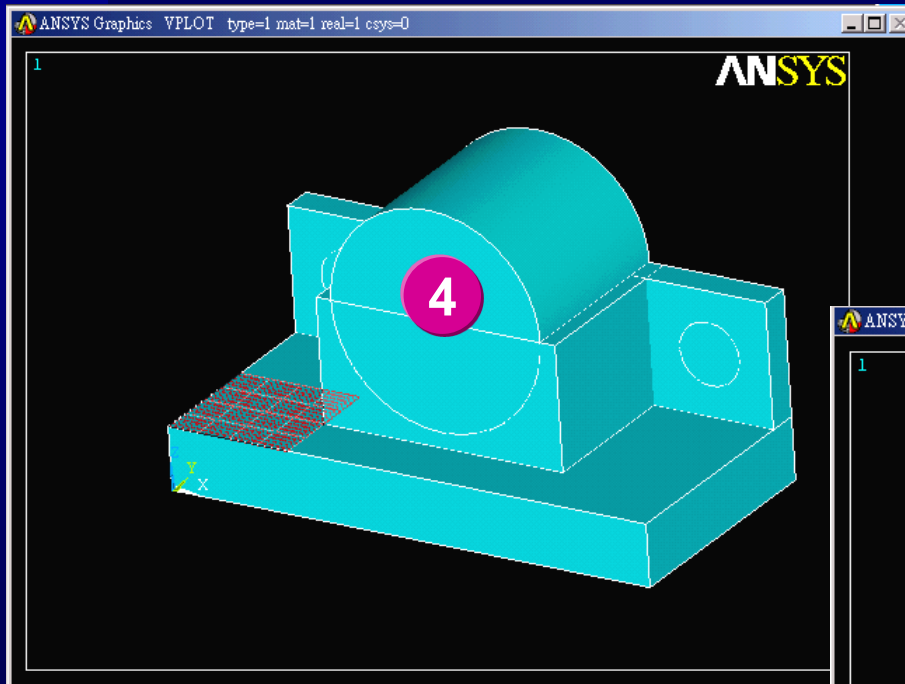

# Introduction of ANSYS

- Preprocessor>Create>Lines>Line Fillet
- Preprocessor>Create>Areas>Arbitrary>By Lines

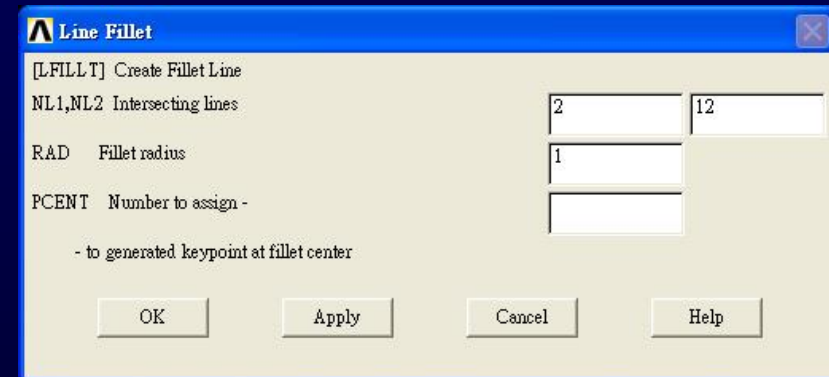
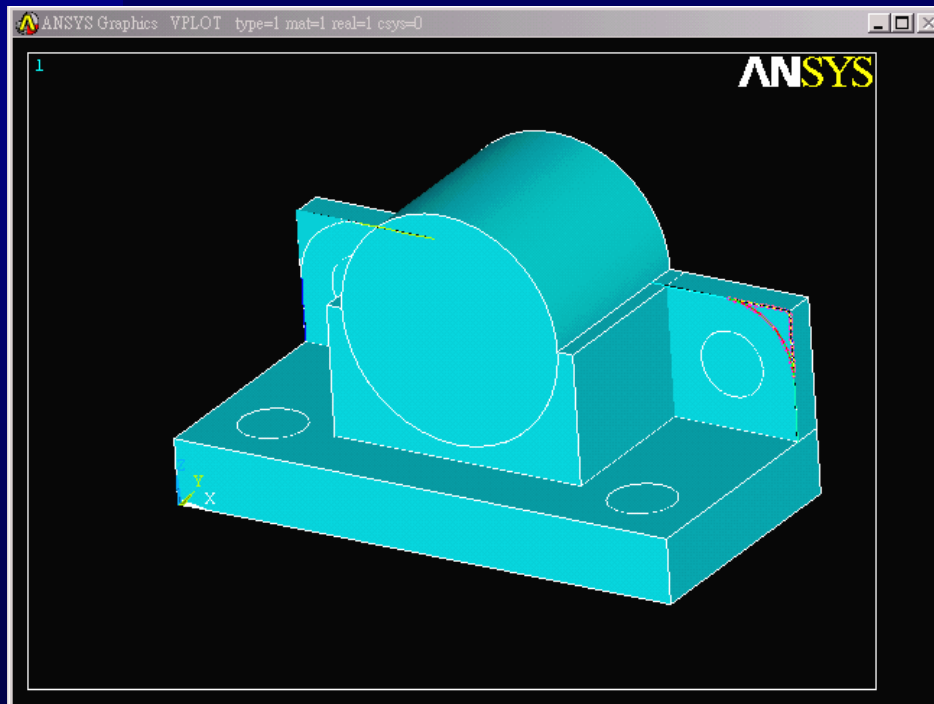

# Introduction of ANSYS

- Preprocessor>Operate>Extrude>Areas>Along Lines

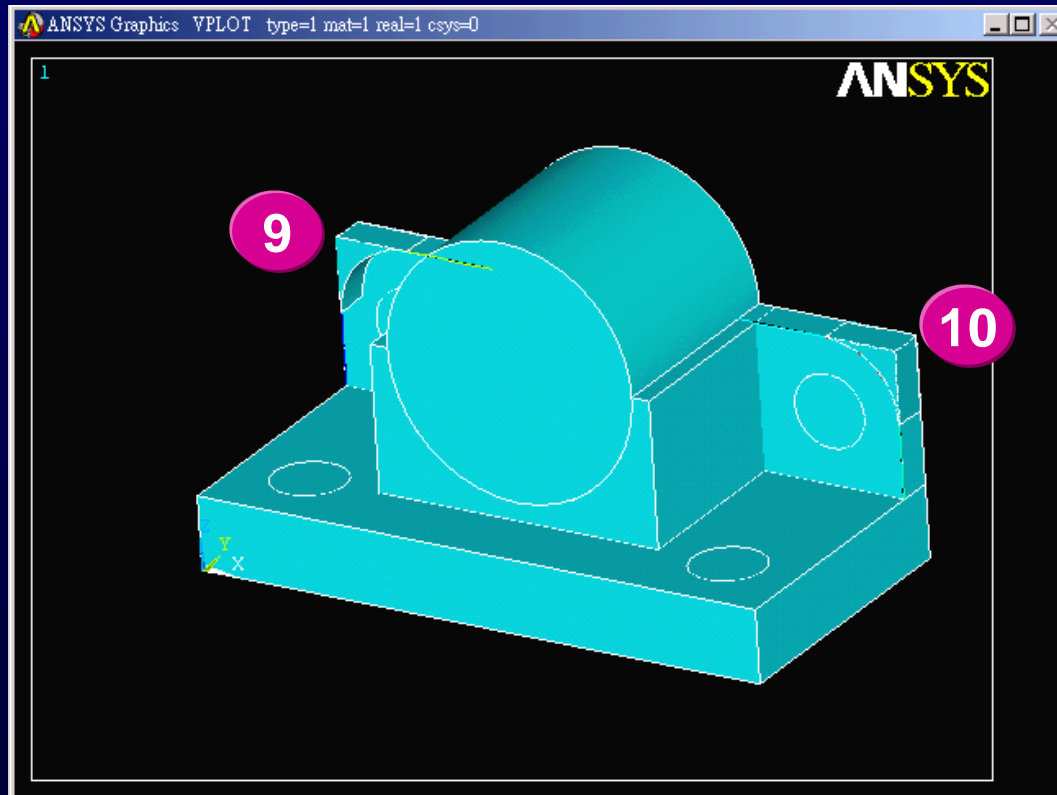

# Introduction of ANSYS

- Preprocessor>Operate>Subtract>Volumes

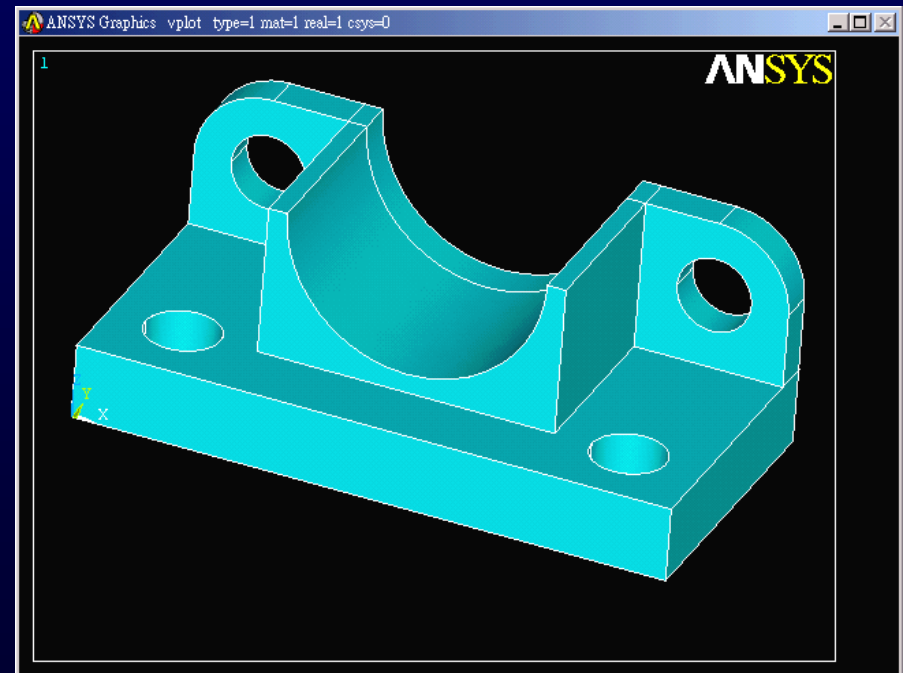
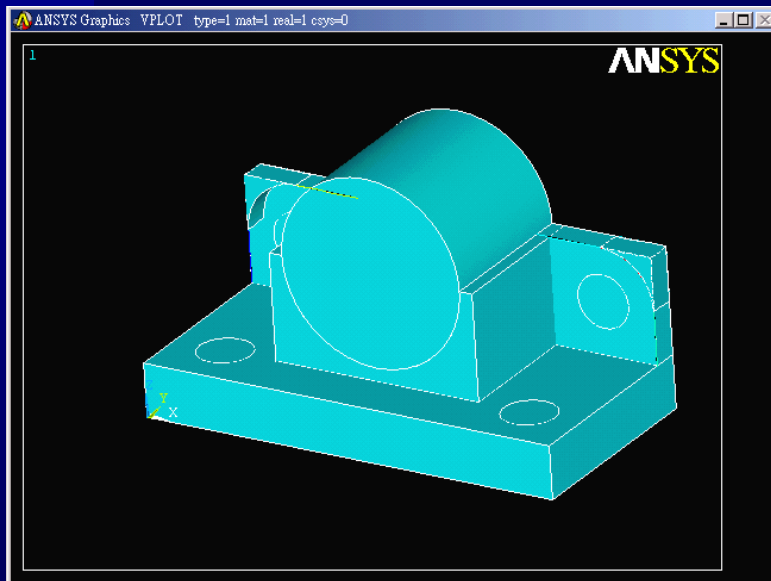

# 3D-modeling: (Ex 6)

Construct the solid model



# 3D-modeling: (Ex 6)

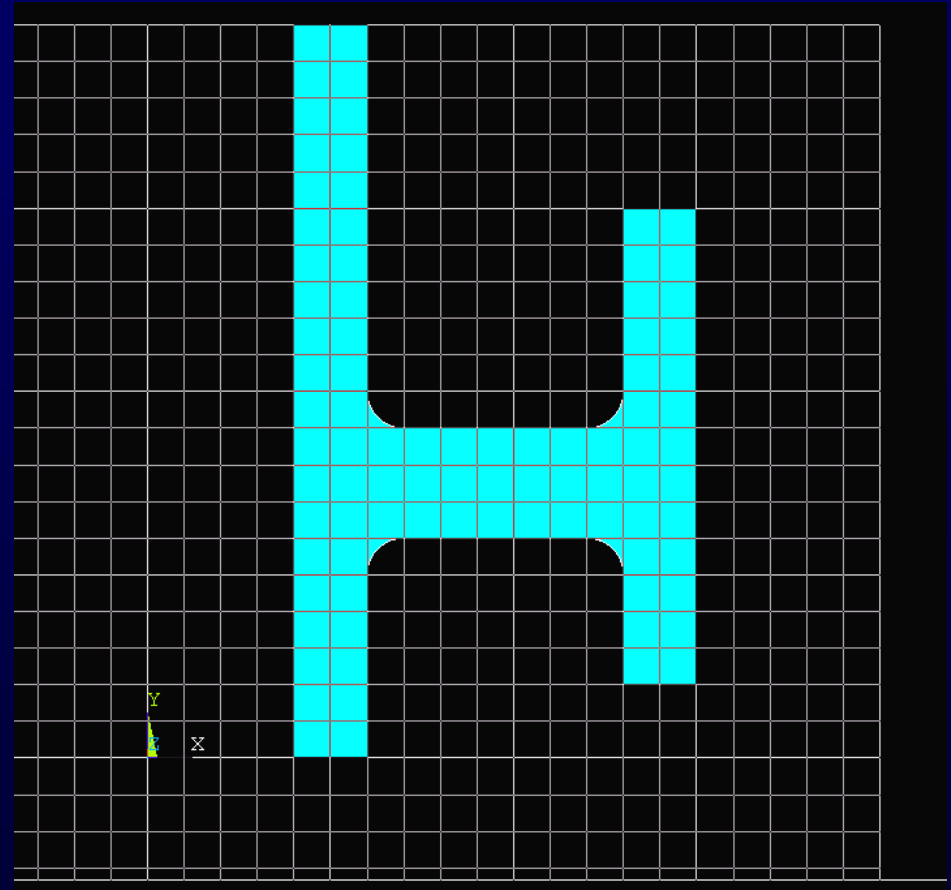
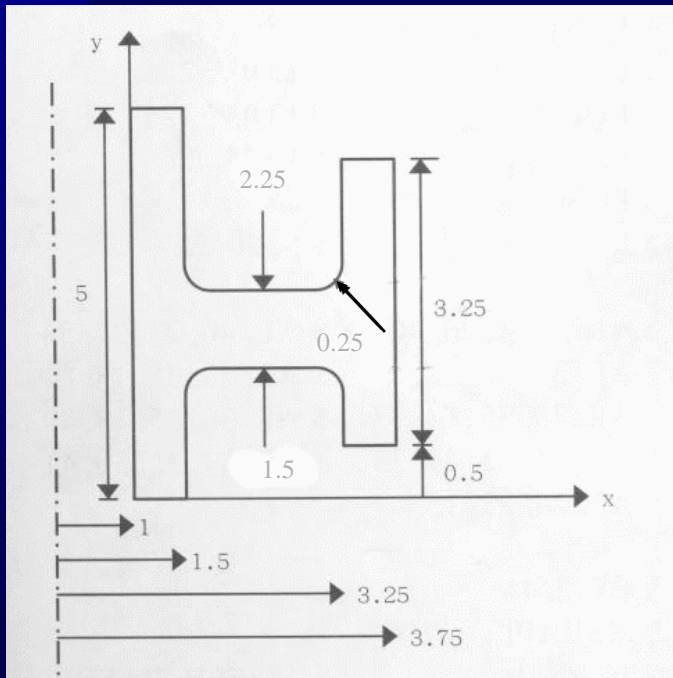

# 3D-modeling: (Ex 6)

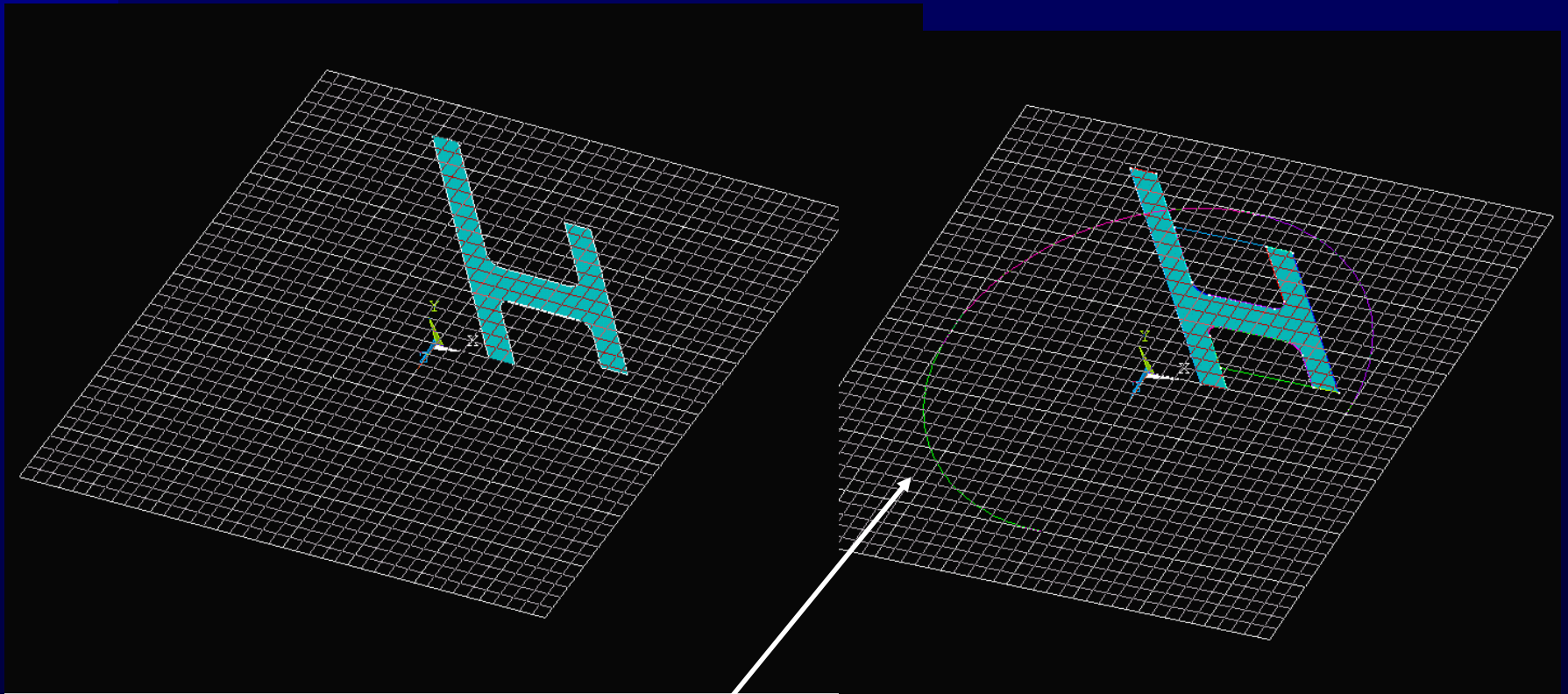

Sweep Line

## 3D-modeling: (Ex 6)

- Main menu>Preprocessor>Modeling>Operate>Extrude>Along Lines (270 °)

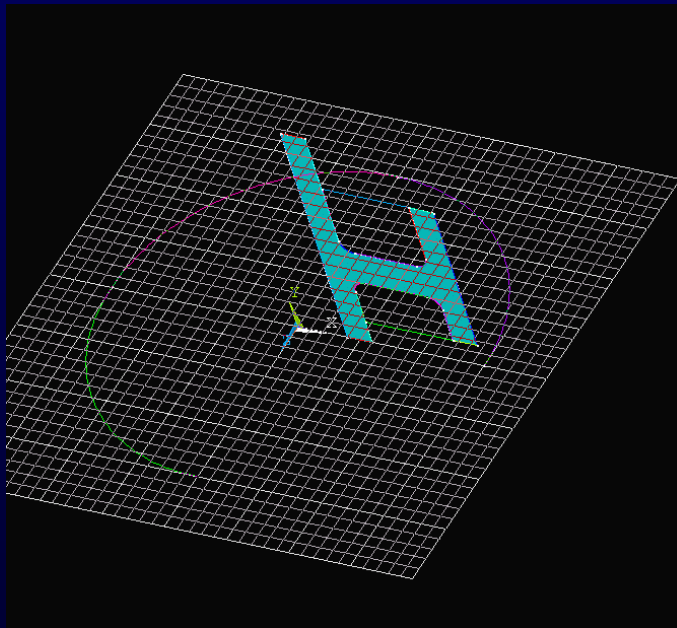

# Introduction of ANSYS

## ■ Pre-processing

### ■ Element type

#### ◆ Real Constants

- Parameters definition for element

### ■ Material Props

### ■ Modeling

### ■ Meshing

#### ◆ Direct generation

#### ◆ Solid modeling

### ■ Other techniques

#### ◆ Merge....

# Introduction of ANSYS

## ■ Mesh approach

■ Direct generation

■ 2D

■ 3D

- ◆ *special efforts* and *time*
- ◆ *ill-conditioned* elements

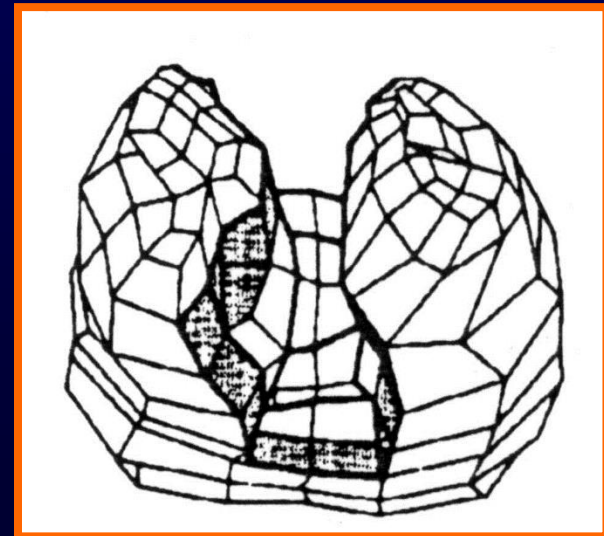
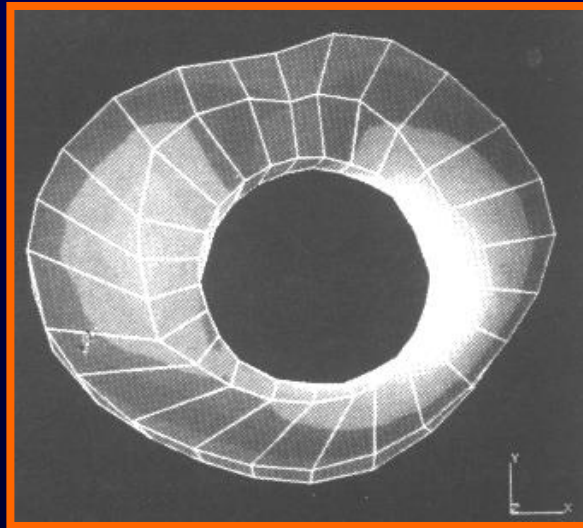

# Introduction of ANSYS

## ■ Mesh Approach

### ■ Solid modeling

- ◆ Free mesh
- ◆ Mapping mesh
- ◆ 依受力狀態，邊界條件而定

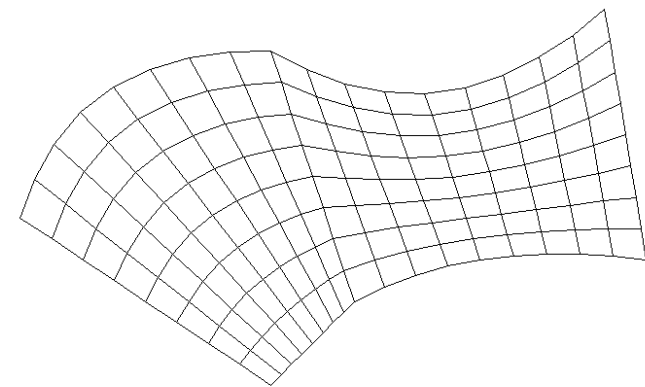
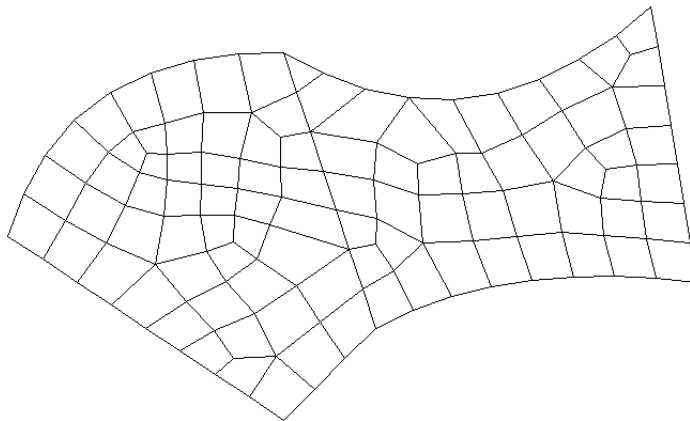
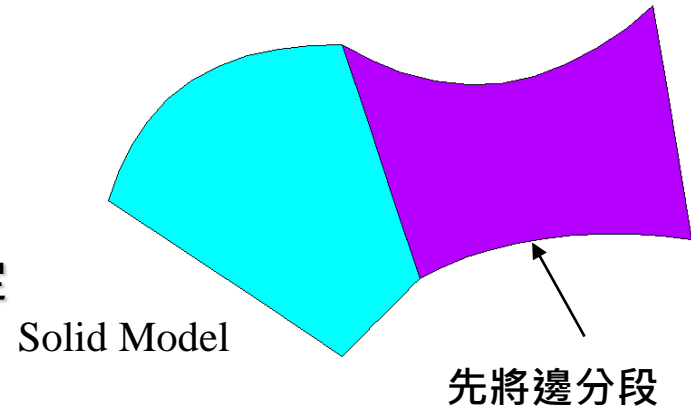

# Introduction of ANSYS

## ■ Mapping mesh

### ■ 面積切割

- ◆ 2D(3 or 4 sides)
- ◆ 3D(4 or 6 sides)

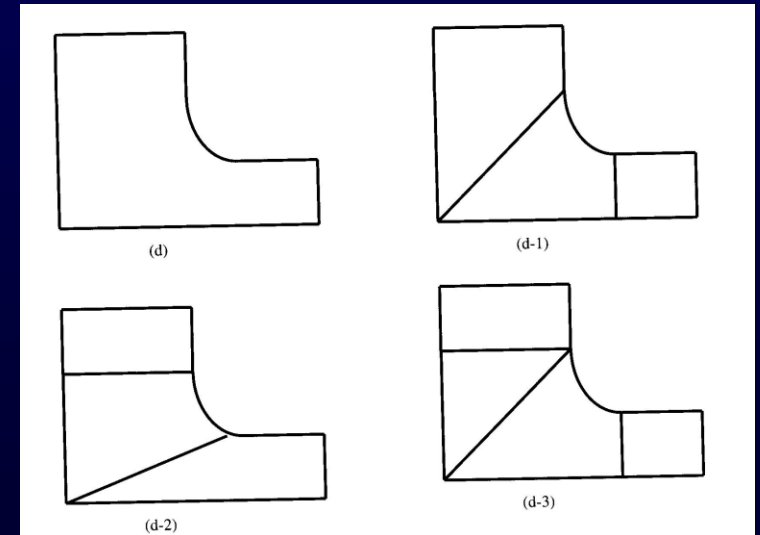
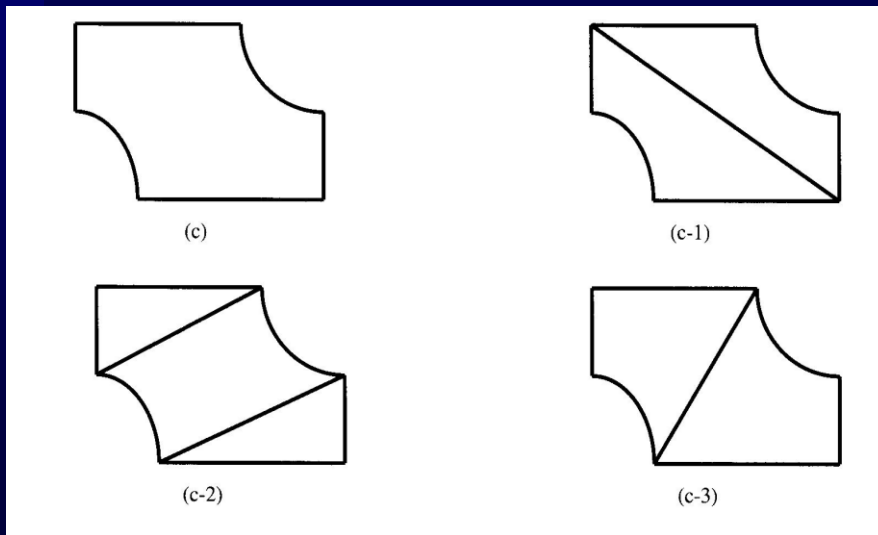
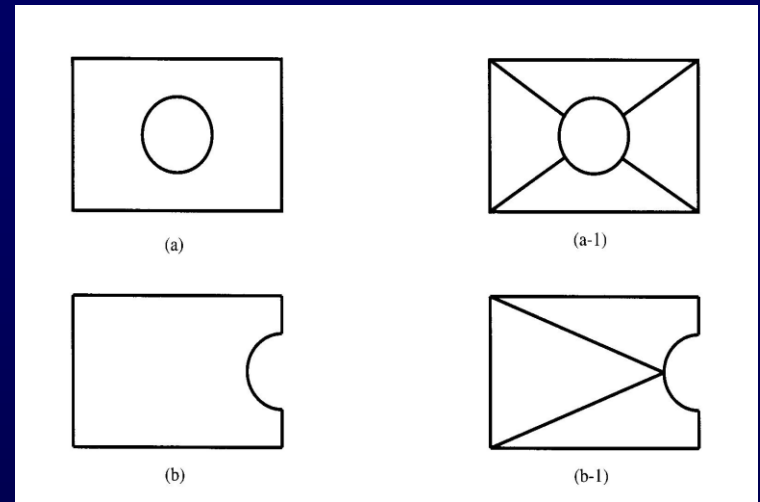

# Introduction of ANSYS

- Ex: Free mesh for Corner Bracket (Element size=0.5)
  - Free mesh > Global size

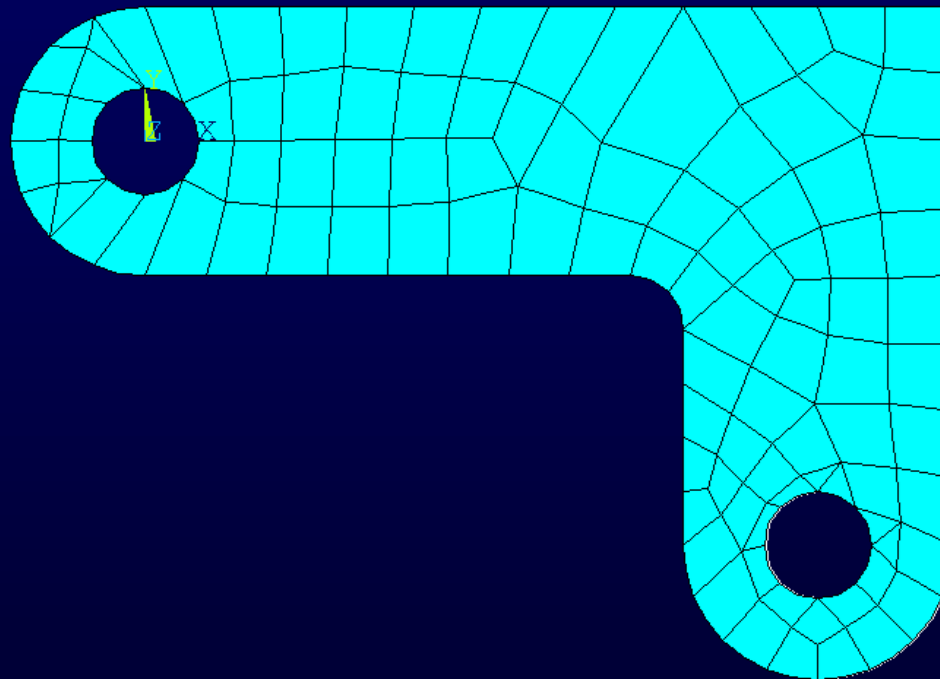

# Introduction of ANSYS

■ Ex:

■ Free mesh>Smart Size (level 5)

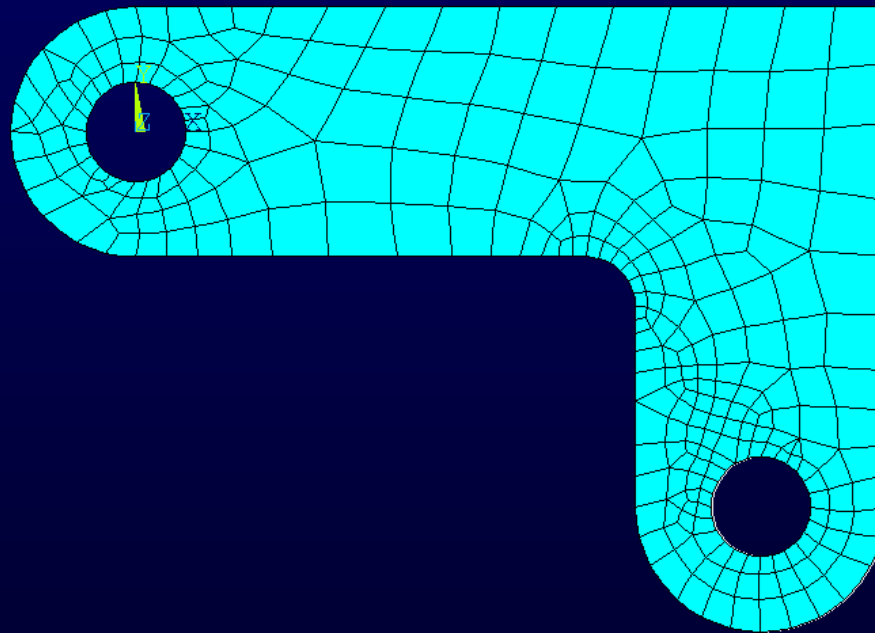

# Introduction of ANSYS

■ Ex:

■ Free & Mapping Mesh (Smart Size)

圓由四段弧線組成

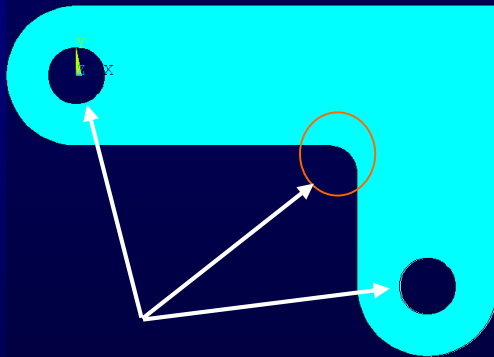

Mapping mesh (切成八段)

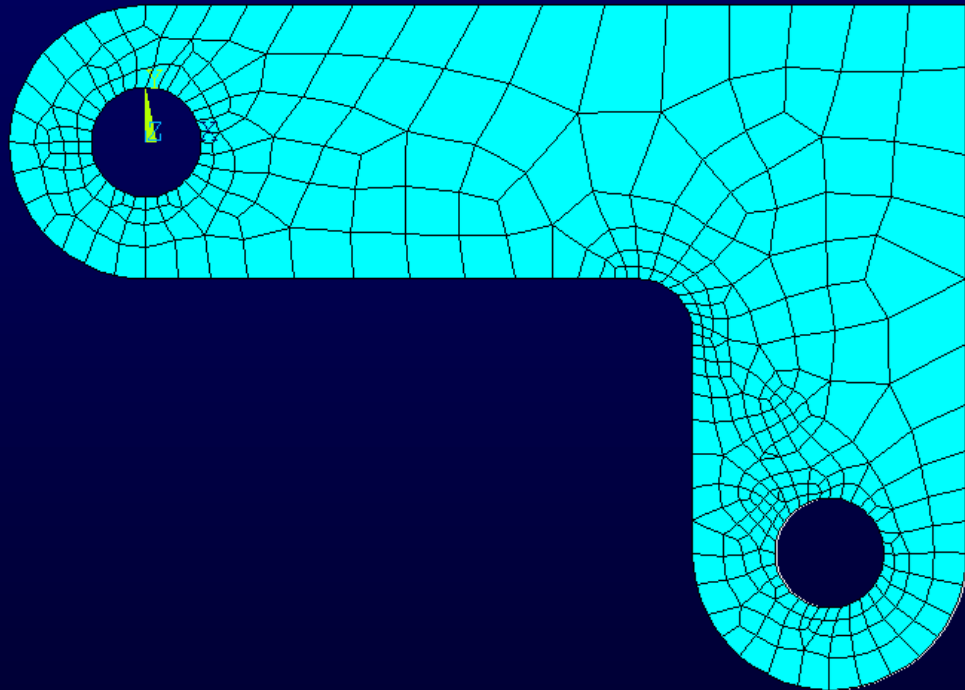

# 3D solid element

## ■ Pre-processing

### ■ Element type

◆ 3D solid element (solid 187, solid 185...)

### ■ Solid 187

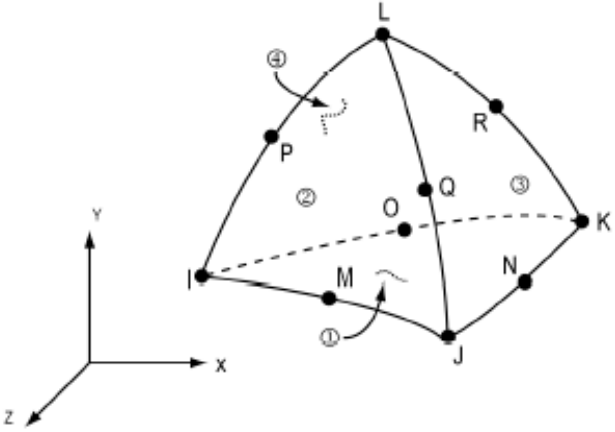
<b>SOLID187</b>	3-D 10-Node Tetrahedral Structural Solid	 <p>The diagram shows a 3D tetrahedral element with 10 nodes labeled I, J, K, L, M, N, O, P, Q, and R. Nodes I, J, K, and L form the outer shell, while M, N, O, P, Q, and R are internal nodes. A 3D coordinate system with x, y, and z axes is shown to the left of the element. Three curved arrows labeled ①, ②, and ③ indicate the degrees of freedom at different nodes.</p>	節點數：10 節點自由度： UX,UY,UZ (u,v,w)
-----------------	---	---	---

### ■ Demo input and output data

# Solid 185/186/187

<p><b>SOLID185</b></p>	<p>3-D Structural Solid</p>	<p>Element Coordinate System (shown for KEYOPT(4) = 1)</p> <p>Surface coordinate system</p> <p>(Prism Option)</p> <p>(Tetrahedral Option-not recommended)</p>	<p>節點數 : 8</p> <p>節點自由度 : UX,UY,UZ (u,v,w)</p>
<p><b>SOLID187</b></p>	<p>3-D 10-Node Tetrahedral Structural Solid</p>		<p>節點數 : 10</p> <p>節點自由度 : UX,UY,UZ (u,v,w)</p>
<p><b>SOLID186</b></p>	<p>3-D 20-Node Structural Solid</p>	<p>(Tetrahedral Option)</p> <p>(Pyramid Option)</p> <p>(Prism Option)</p>	<p>節點數 : 20</p> <p>節點自由度 : UX,UY,UZ (u,v,w)</p>

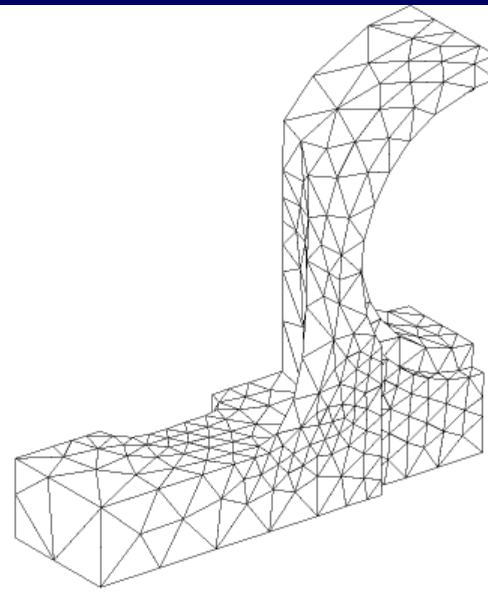

Size Level = 6  
(default)

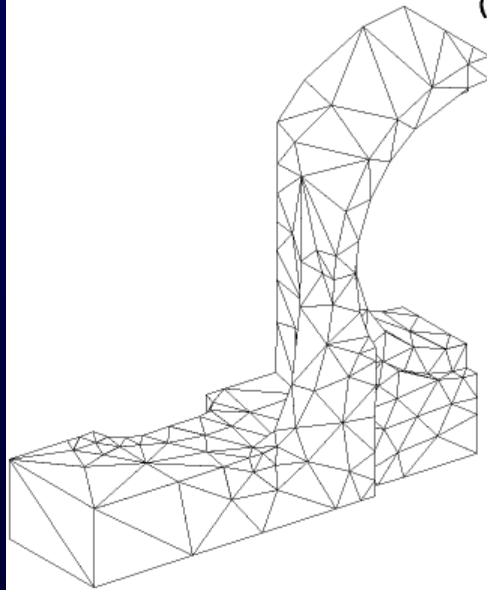

Size Level = 10  
(coarser)

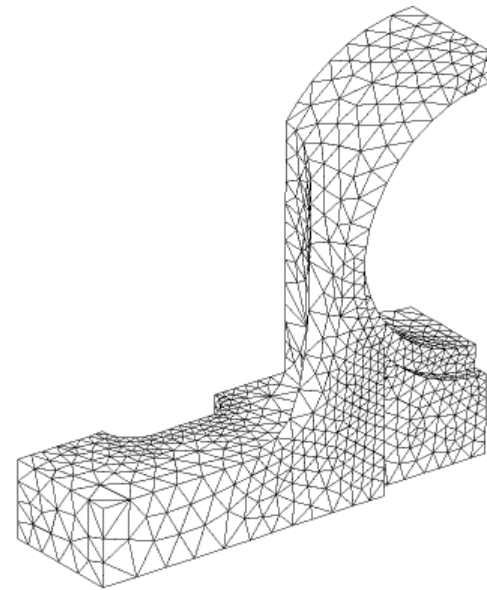

Size Level = 2  
(finer)

# Mesh example: (Ex 7)

- Main Menu>Preprocessor>Operate>Extrude
- Plane Mesh
  - ◆ Smart Size (4)

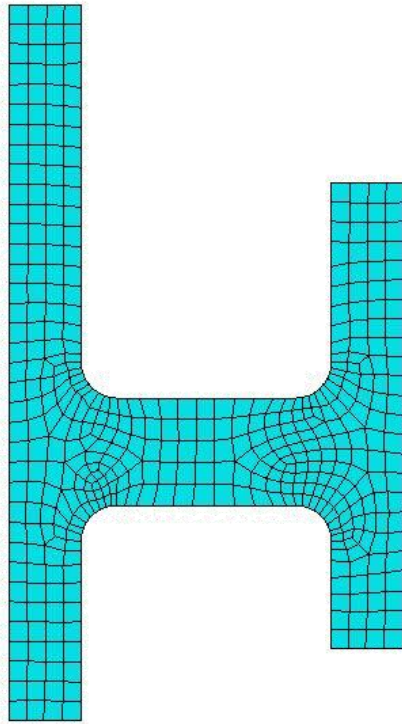

Plane 182

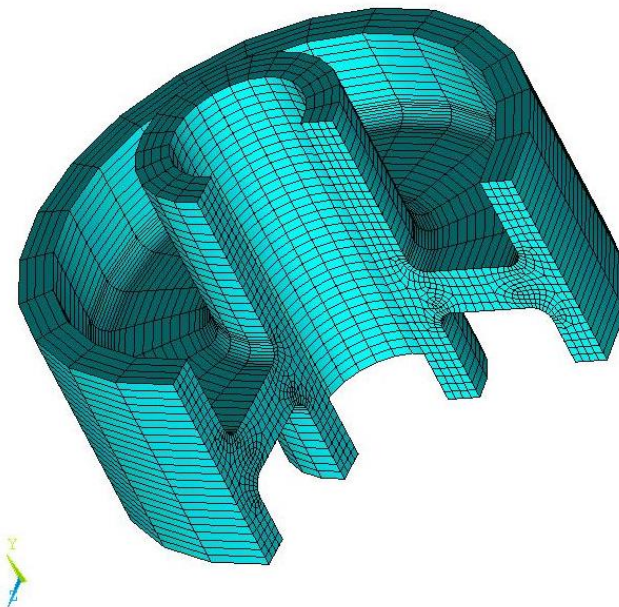

Solid 185

# Mesh example: (Ex 8) (自行練習)

- To generate the mapping and free meshes

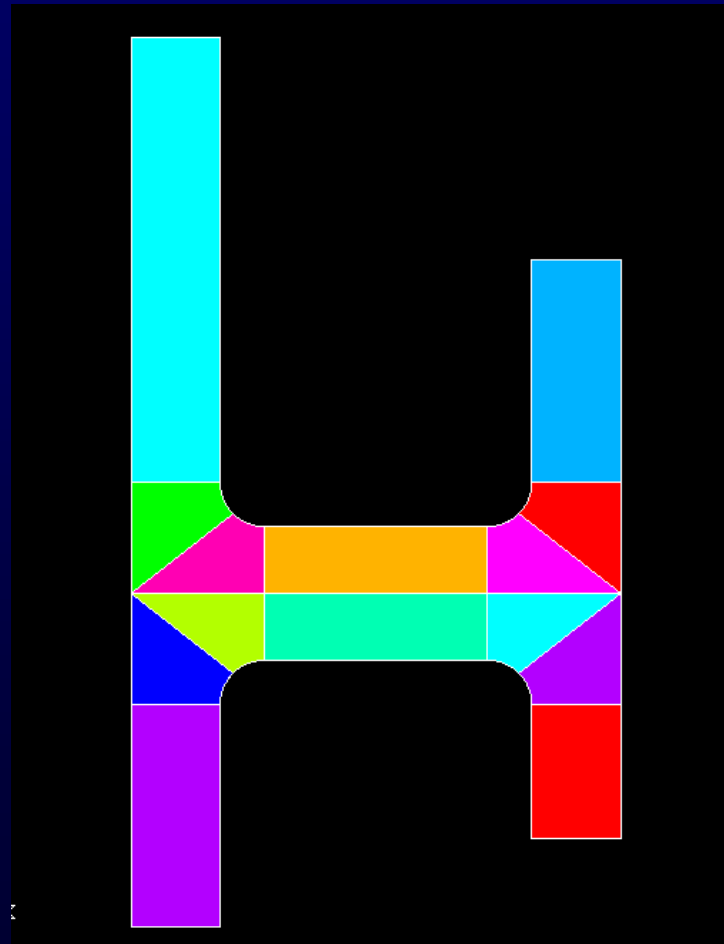

# Mesh example: (Ex 8)

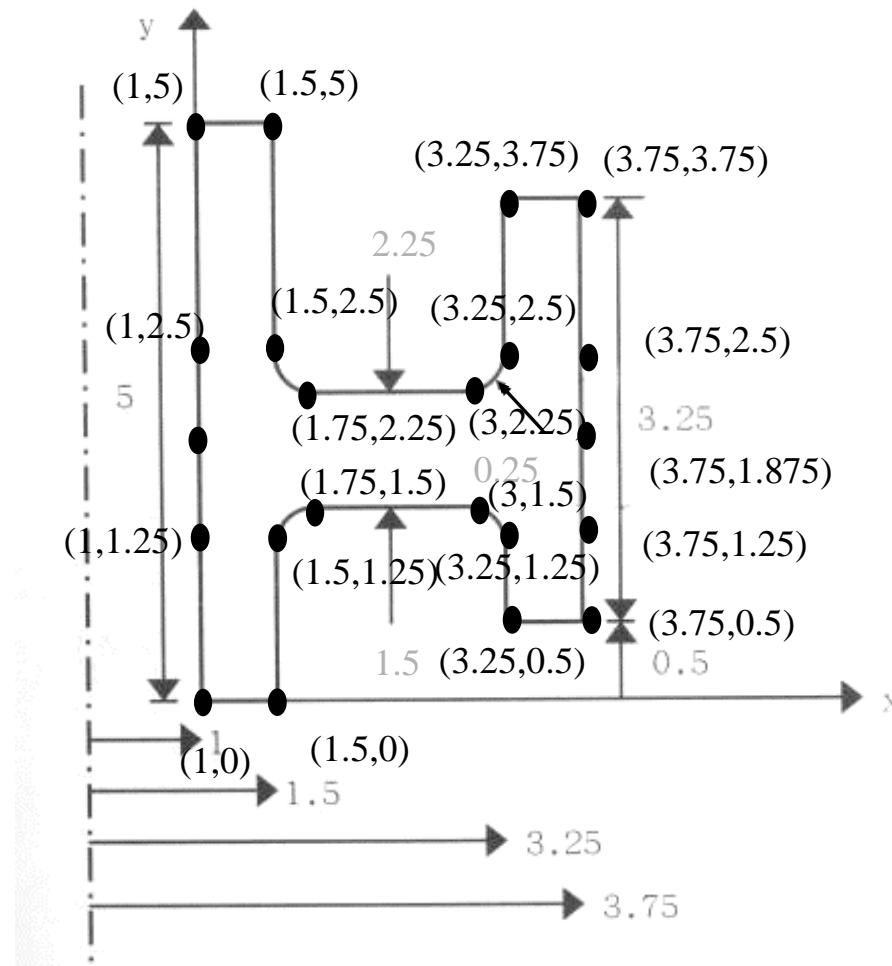

# Mesh example: (Ex 8)

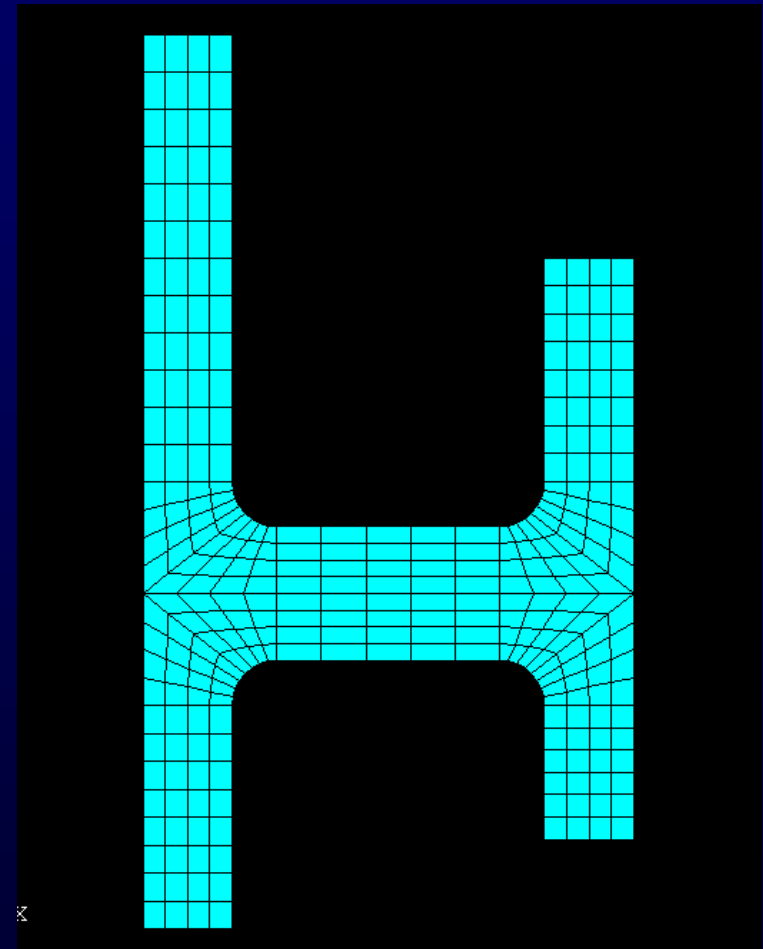
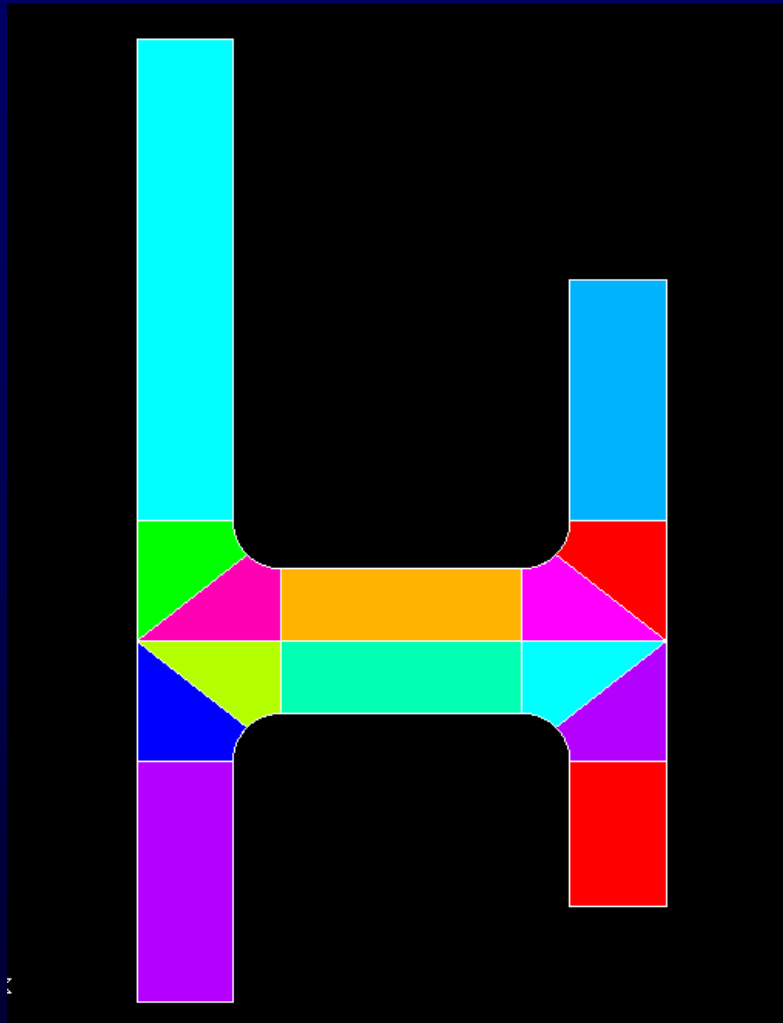

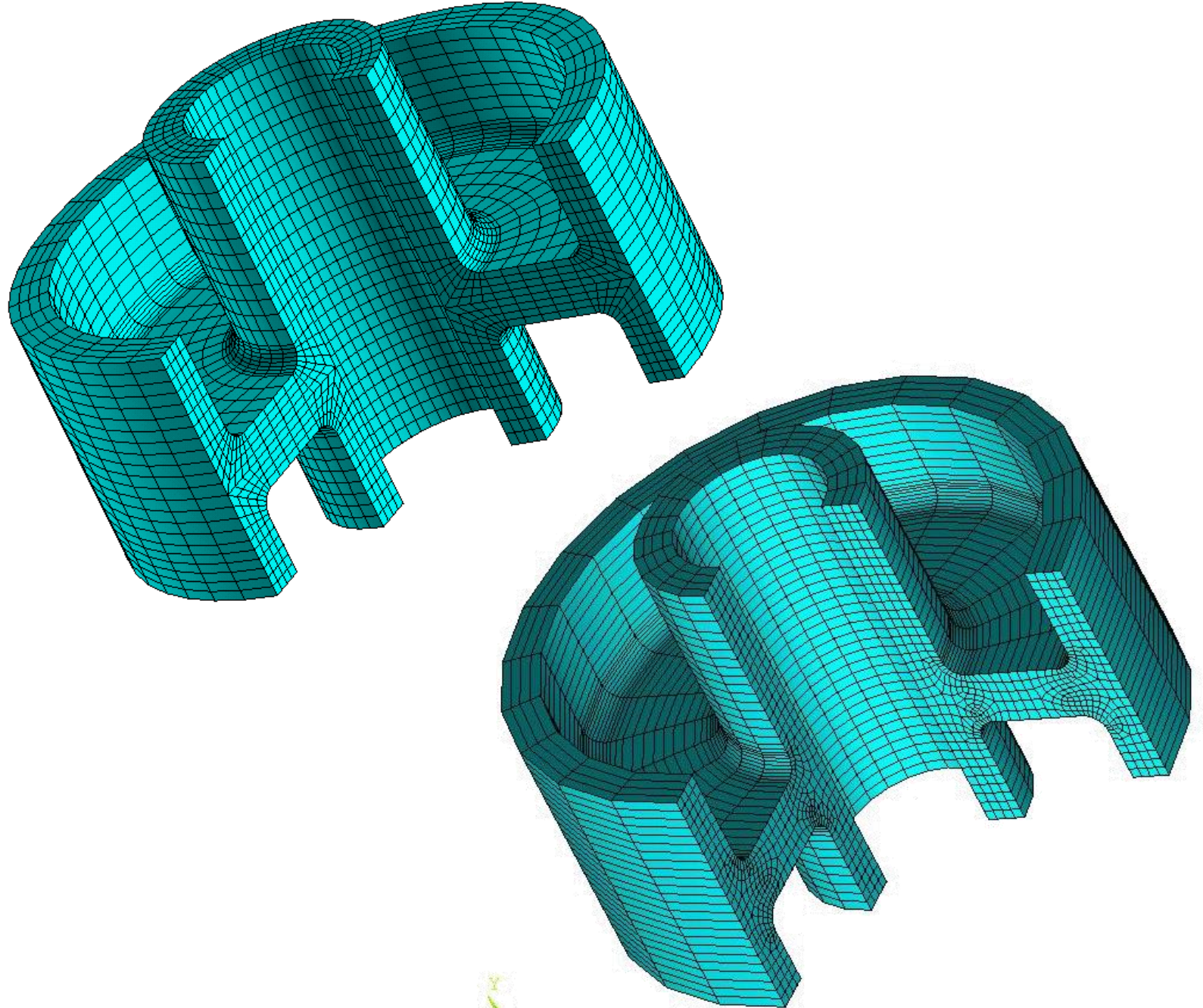

# Introduction of ANSYS

- 1.元素的連續性，相鄰元素需使用共同的節點和自由度。
- 2.元素的選用需一致，例如二維和三維的元素不可參雜使用。
- 3.三角形和契形元素可被使用於過度區。
- 4.元素需盡可能保持其原來的形狀，即不能扭曲太嚴重。
- 5.在施力處的網格分割需良好。
- 6.在預期應力集中處如孔洞、凹槽等處的分割，元素尺寸需較小且分佈良好。
- 7.網格的分割的密度需盡可能隨應力分佈而調整。

## 3D solid element example: (Ex 9)(SOLID187)

- The bracket shown in figure is subjected to a distributed load of 50 lb/in<sup>2</sup> on the top surface. It is fixed around the hole surface. The bracket is made of steel, with a modulus elasticity of 29\*10<sup>6</sup> lb/in<sup>2</sup> and  $\nu=0.3$ . Plot the deformed shape. Also, plot the von Mises stress distribution in the bracket.

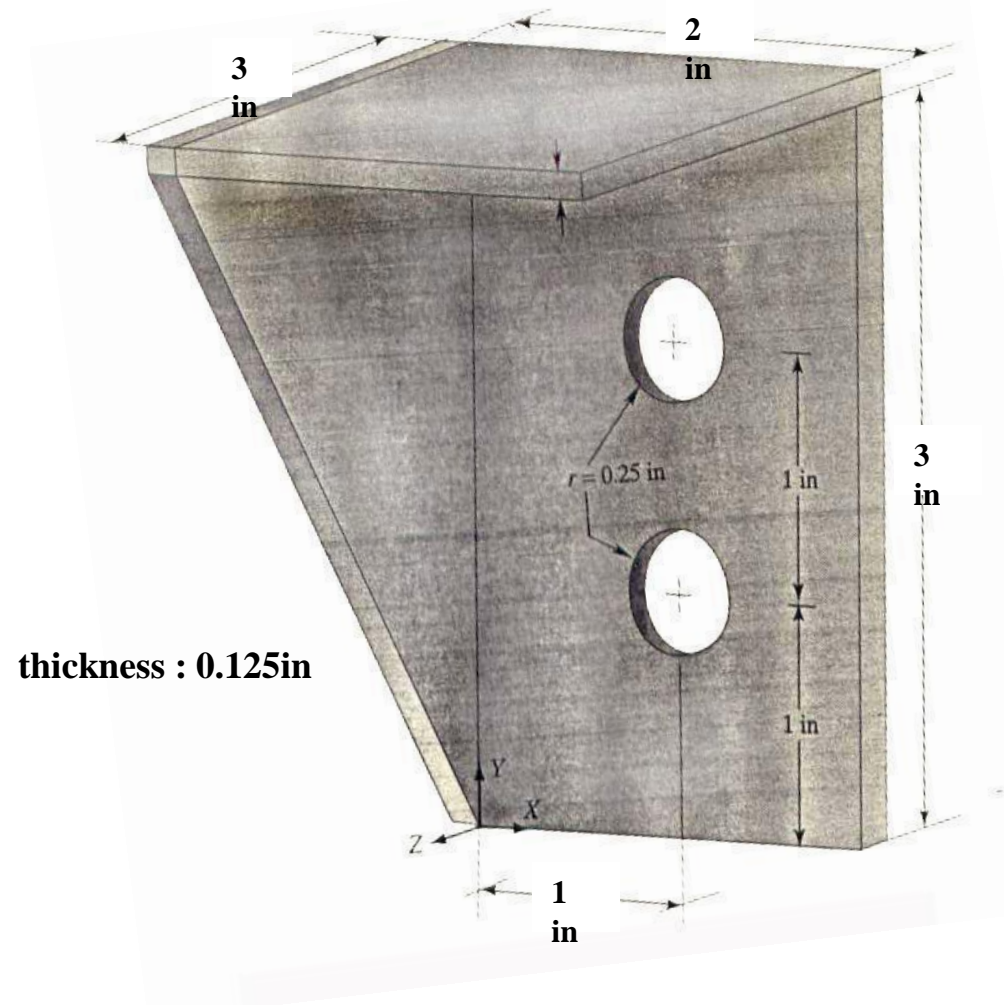

# Introduction of ANSYS

收斂物理量通常可為應力/位移/能量  
誤差最好於5%內

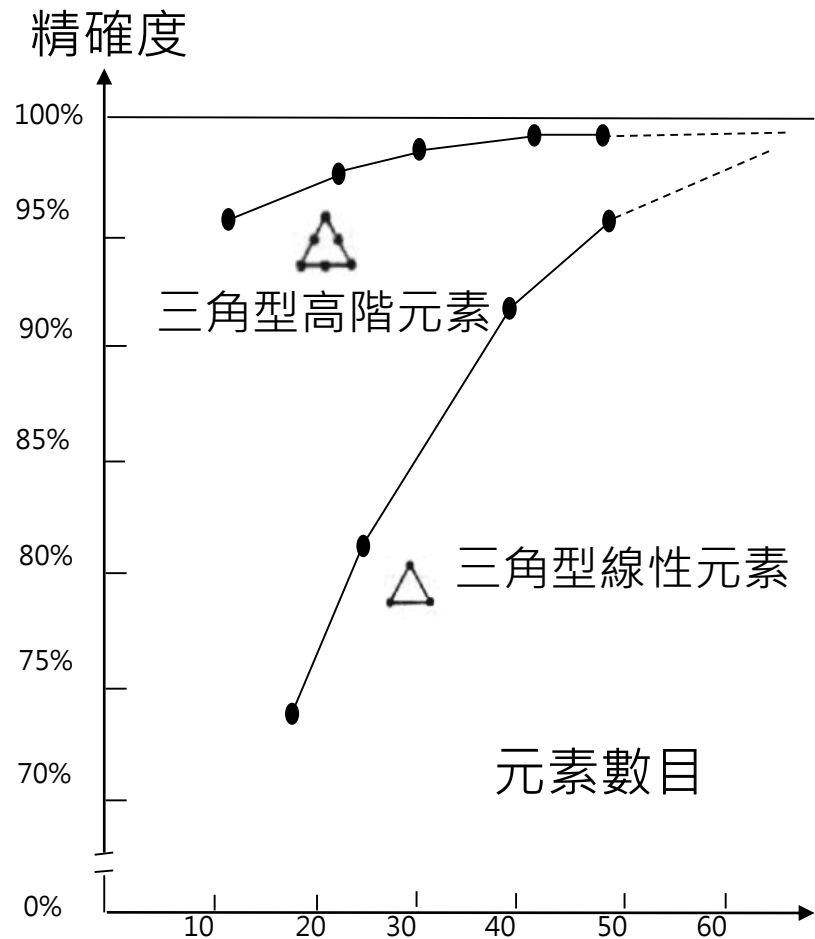
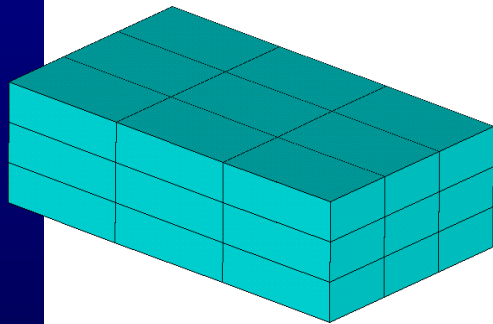

# Introduction of ANSYS

- 3D Intact Tooth Models

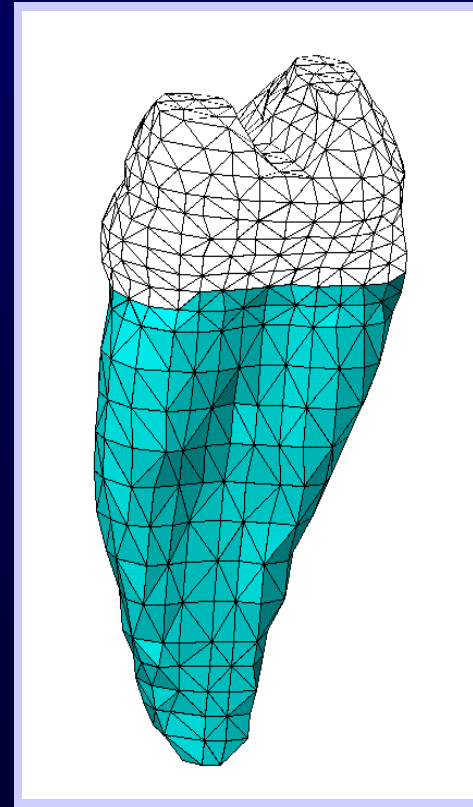
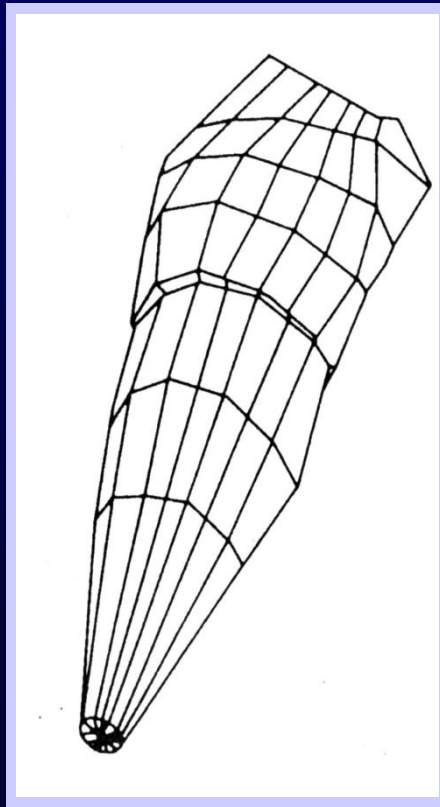

# Convergence example (Ex 10)

## ■ 實體元素分析

如圖為一機械元件，兩圓孔半徑均為15mm， $a=170\text{mm}$ ， $b=110\text{mm}$ ， $c=120\text{mm}$ ， $R_1=R_2=10\text{mm}$ ， $R_3=R_4=20\text{mm}$ ， $L=100\text{mm}$ ， $d=110\text{mm}$ ， $e=50\text{mm}$ ，板為等厚度 $t=10\text{mm}$ 。板面受壓力 $p=0.1\text{MPa}$ ，底部圓孔為固定拘束，其材料之楊氏模數 $E=210\text{GPa}$ ，普松比 $\nu=0.3$ ，試求結構之應力場與變形。分析單位系統採用： $\text{mm}$ 、 $\text{N}$ 、 $\text{MPa}$ 。

本例可使用SOLID185、SOLID186、SOLID187等實體元素來模擬，首先採用SOLID186的高階20節點元素

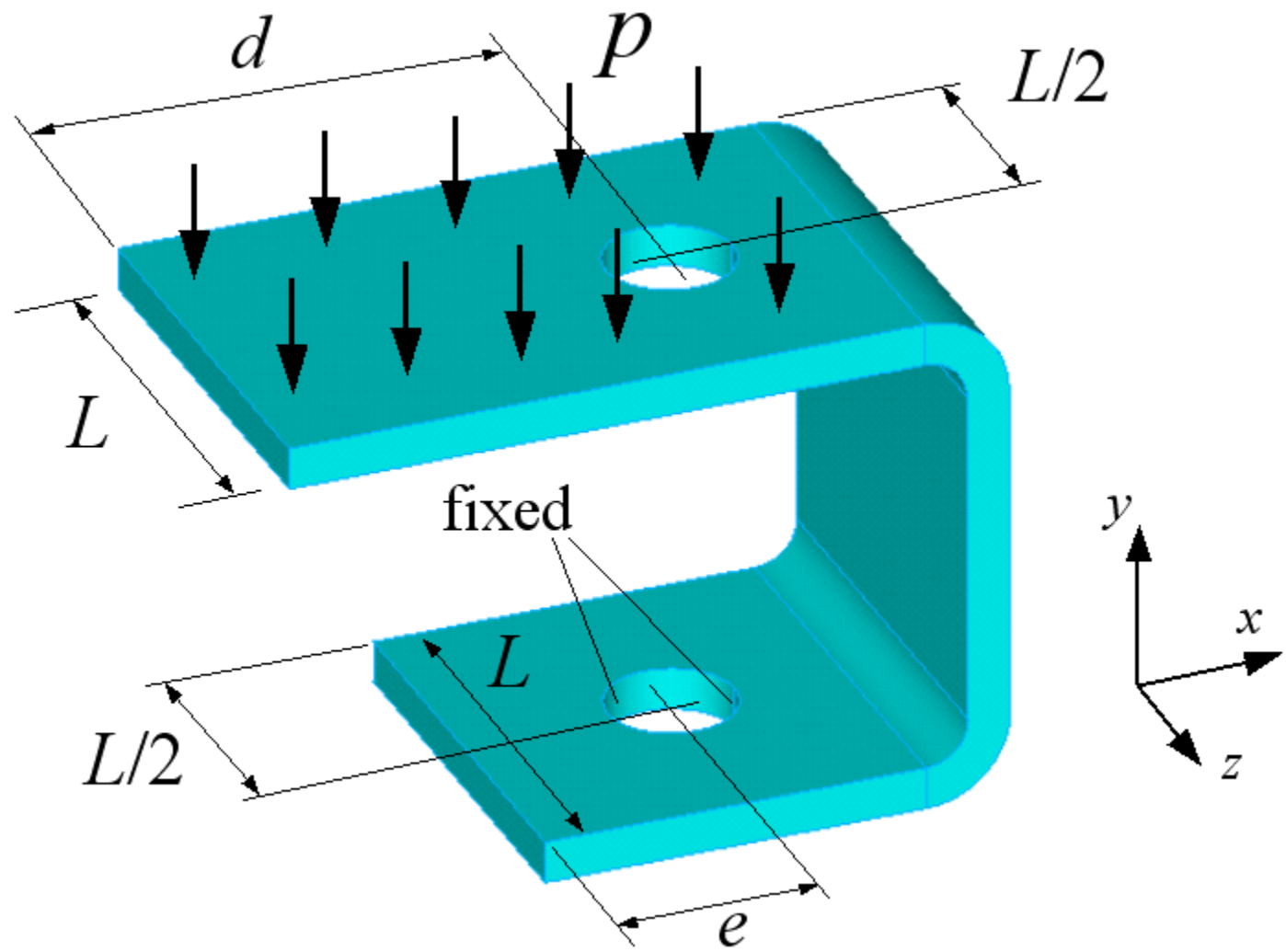

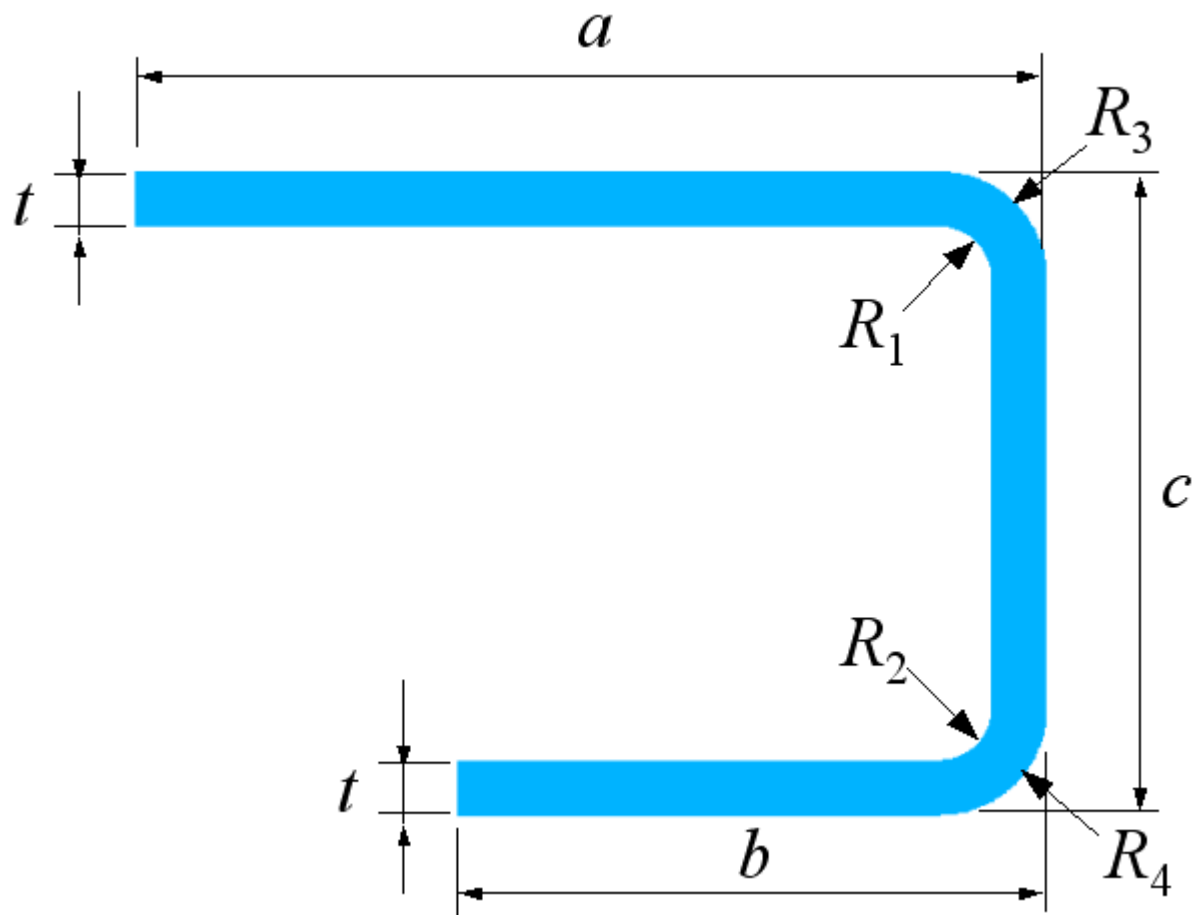

- 兩圓孔半徑均為15mm， $a=170\text{mm}$ ， $b=110\text{mm}$ ， $c=120\text{mm}$ ， $R_1=R_2=10\text{mm}$ ， $R_3=R_4=20\text{mm}$ ， $L=100\text{mm}$ ， $d=110\text{mm}$ ， $e=50\text{mm}$ ，板為等厚度 $t=10\text{mm}$ 。

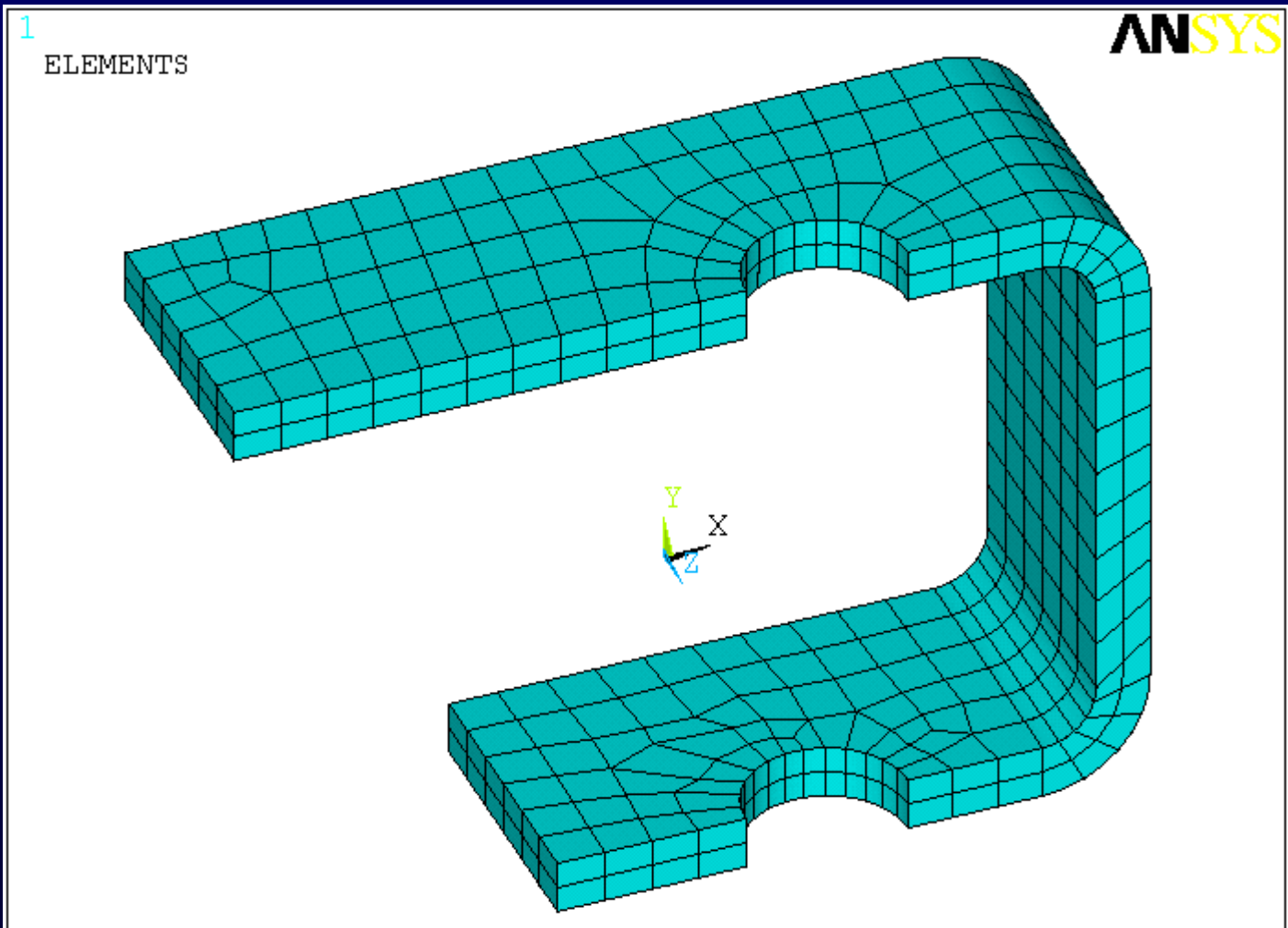

Solid186



# von Mises 等效應力 $\sigma_{eqv}$ (SEQV) (MPa)

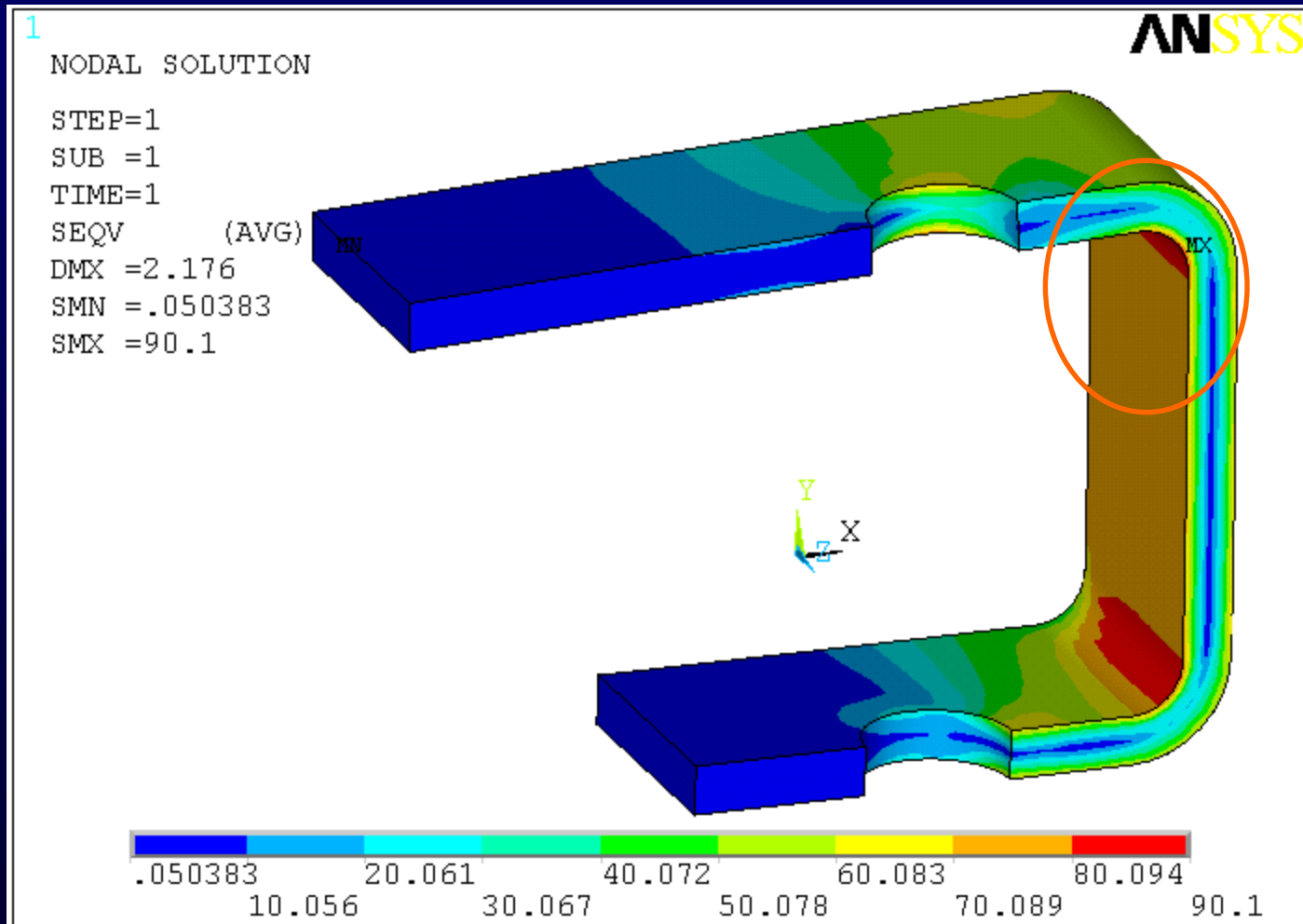

# 位移v(UY)(mm)

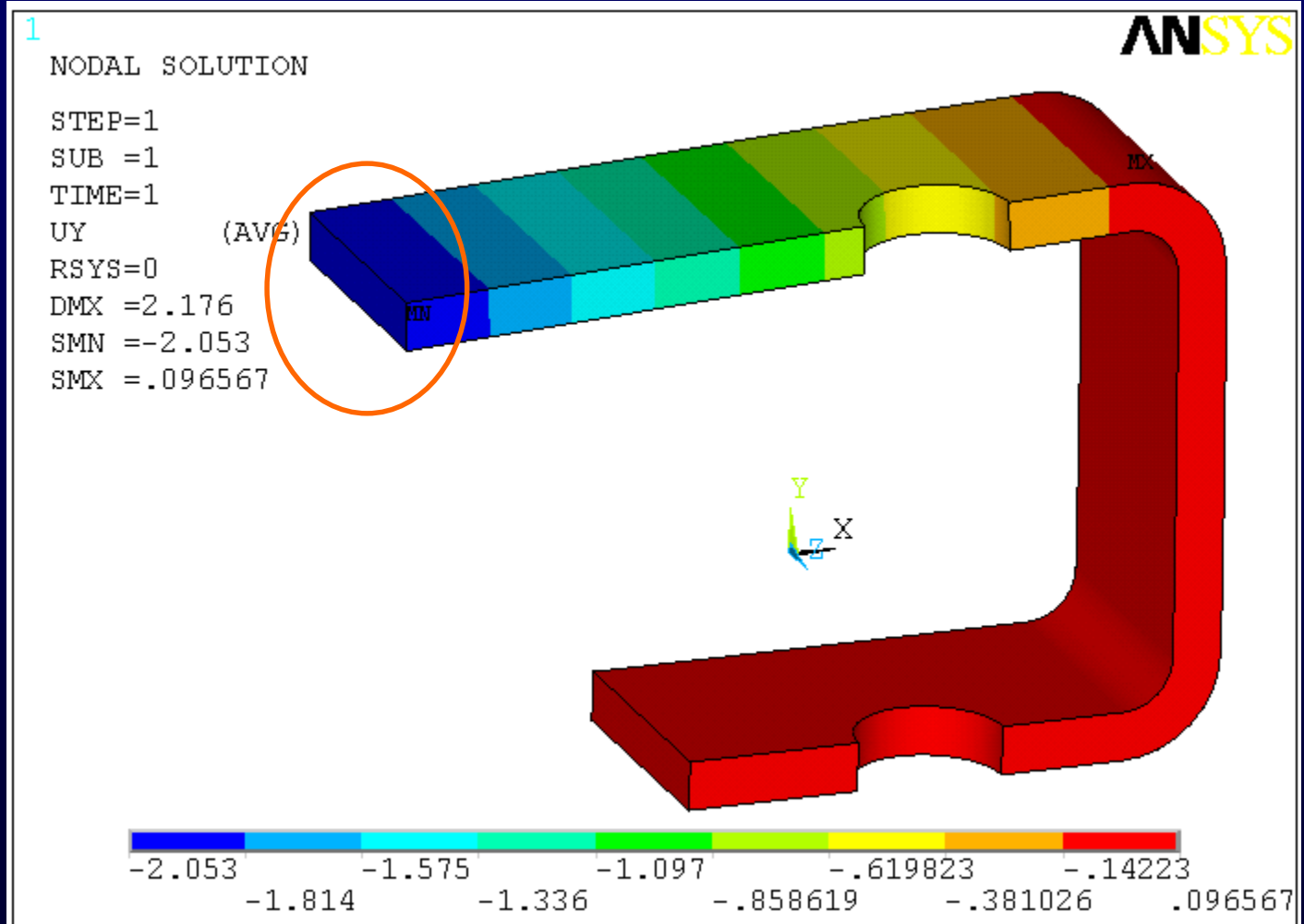

# 感興趣各點之等效應力 (各點數值是否收斂)

Main Menu>General Postproc>Query results>Subgrid Solu>Pick

因無正確解析解,因此需進行重新Mesh

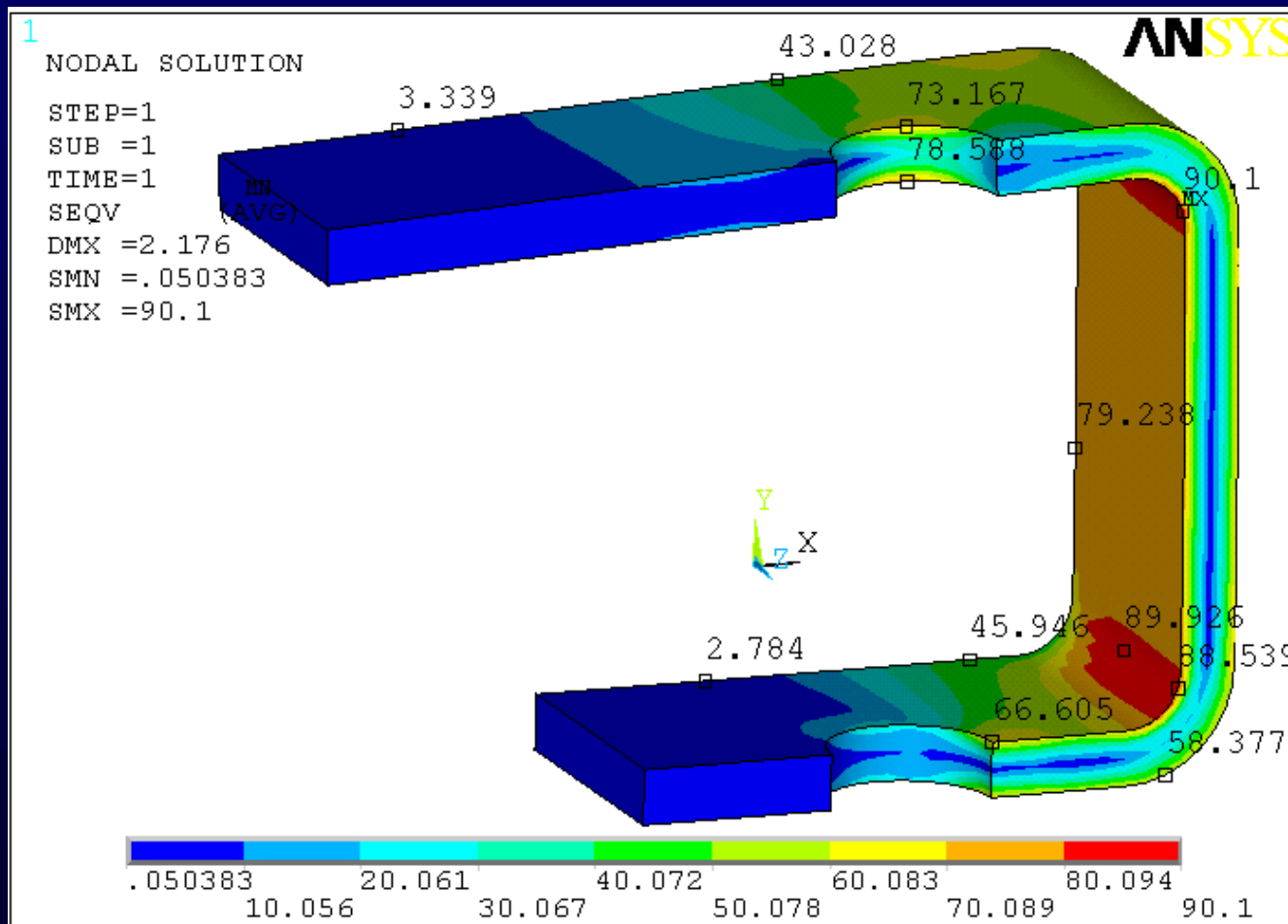

# 細分網格後之有限元素模型(圓角及厚度層數)

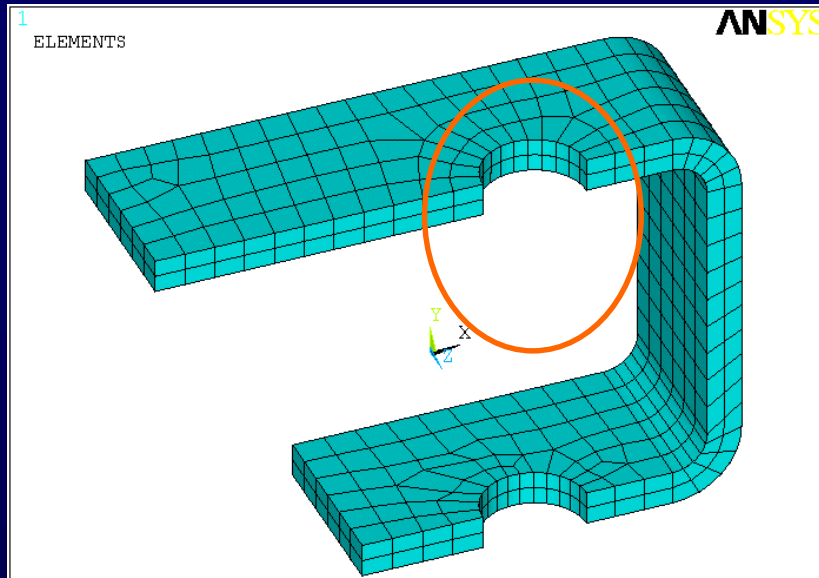

ex5-8a. Machine component (SQ17505 element)

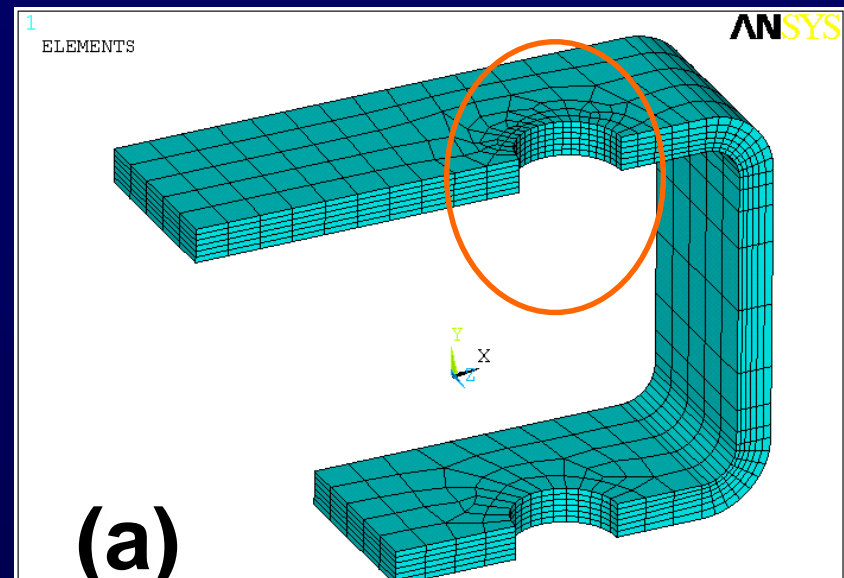

(a)

elements, refined mesh)

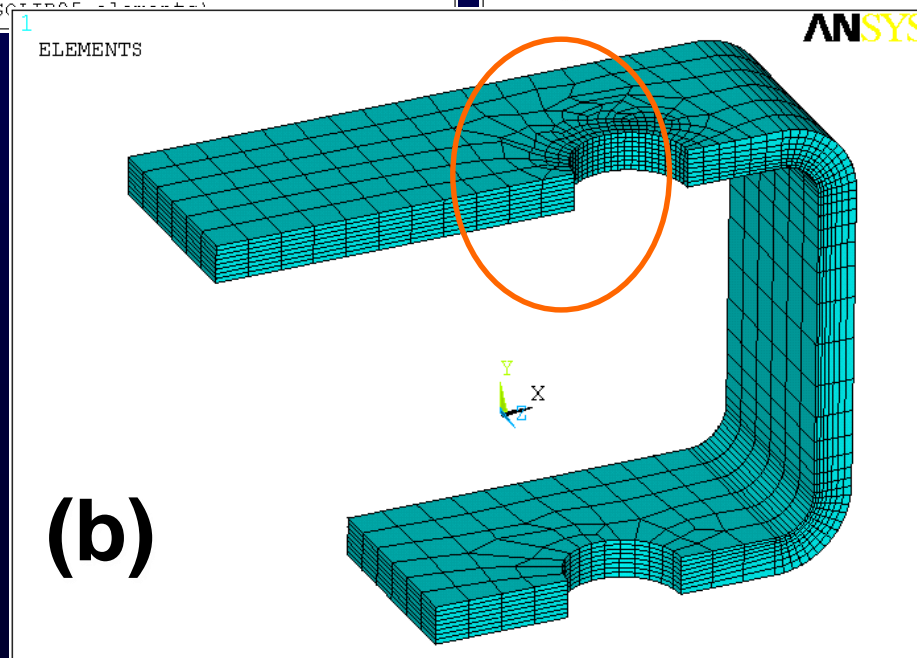

(b)

# 細分網格後之等效應力比較

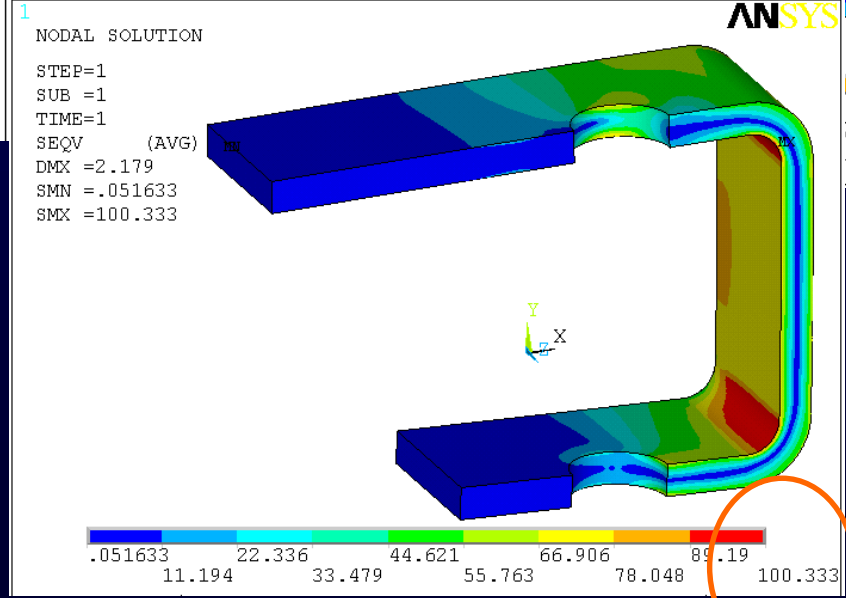
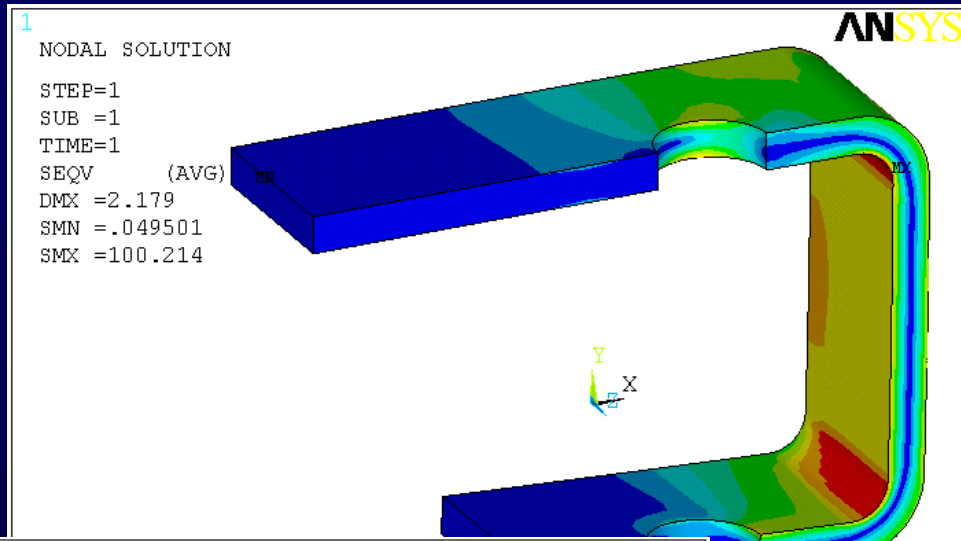
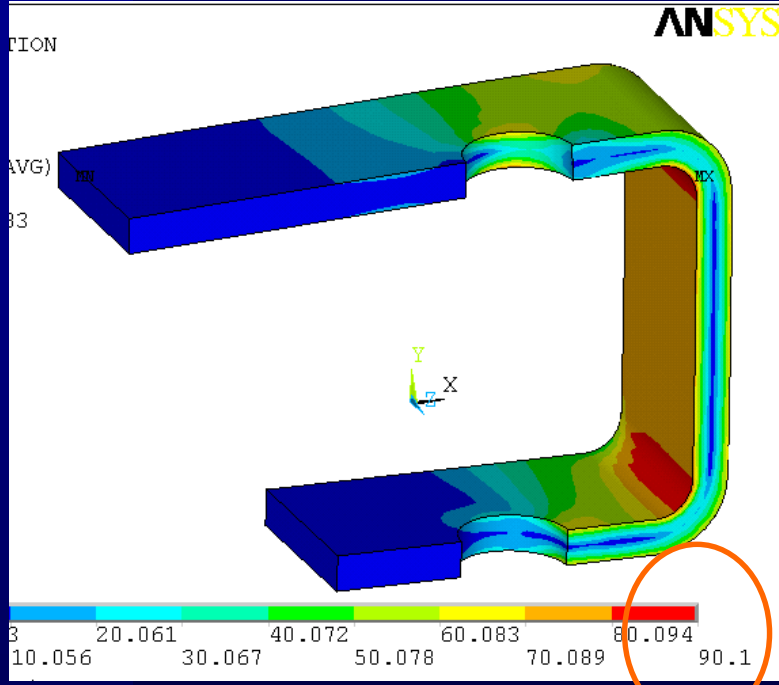

```

1
NODAL SOLUTION
STEP=1
SUB =1
TIME=1
SEQV (AVG)
DMX =2.179
SMN =.049501
SMX =100.214

```

```

1
NODAL SOLUTION
STEP=1
SUB =1
TIME=1
SEQV (AVG)
DMX =2.179
SMN =.051633
SMX =100.333

```

- 經由表比較分析，以位於圓角R1的結構最大 von Mises 等效應力為例，Case2和Case3的應力值變化為 0.12%，而Case3在圓角R1區之元素大小是Case2的 58%，所以可將Case2答案視為已達收斂，Case2的有限元素模型計算結果是足夠準確的。

Case	ANSYS log file	局部元素大小(mm) (厚度方向)			節點 總數量	局部高應力值 等效應力 $\sigma_{eqv}$ (MPa)			B 點位移 v (mm)
		上圓孔 底部	圓角 R <sub>1</sub>	圓角 R <sub>2</sub>		上圓孔 底部	圓角 R <sub>1</sub>	圓角 R <sub>2</sub>	
1	ex5-8a.log	5	5	5	3504	78.588	90.1	89.926	-2.053
2	ex5-8b.log	1.67	1.15	1.15	9871	79.646	100.214	99.160	-2.056
3	ex5-8c.log	1.25	0.67	0.68	20749	80.006	100.333	99.279	-2.056

- 若網格化方式改成自由網格 (free mesh)，且使用 SOLID187 高階 10 節點三角錐元素，在 ANSYS 執行後的有限元素模型如圖，而計算結果如下圖，為：A 點 (圓角  $R_1$ ) 的最大等效應力  $\sigma_{eqv} = 101.478 \text{ MPa}$ ，B 點的最大 y 方向位移  $v = -2.054 \text{ mm}$ 。

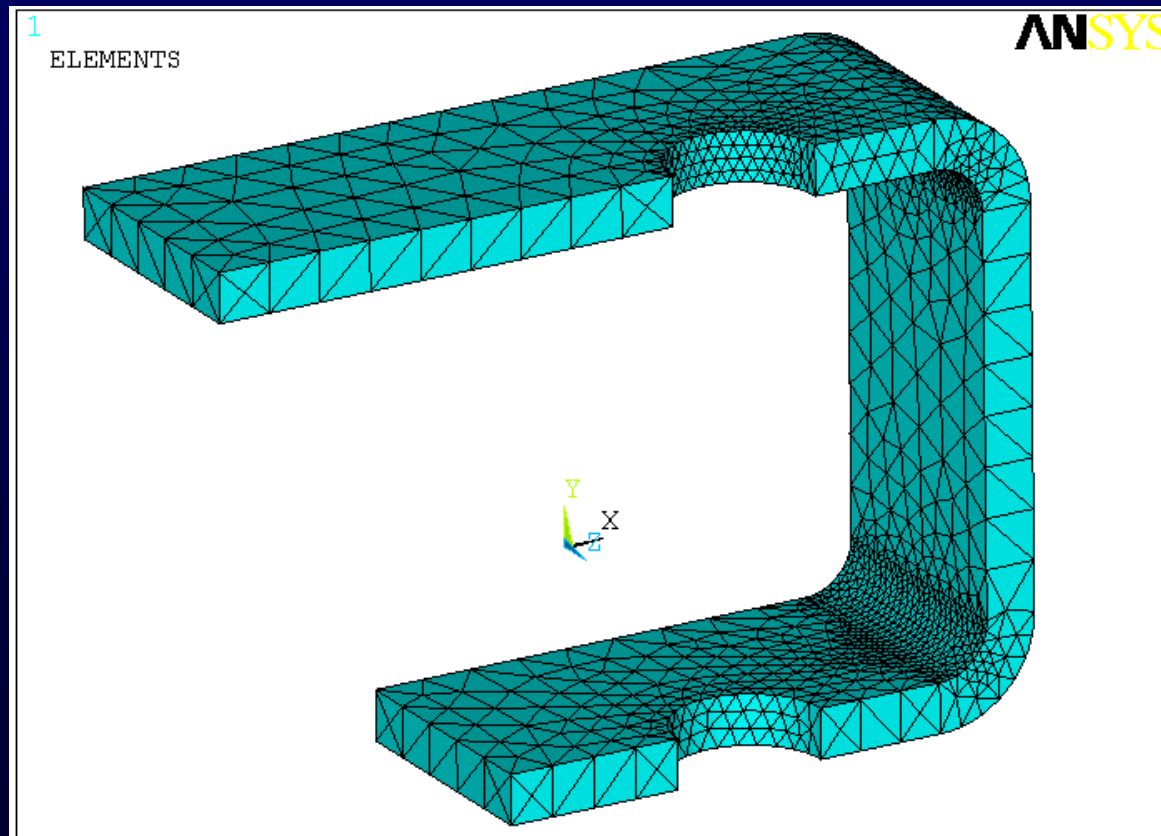

# SOLID187 計算結果(a)

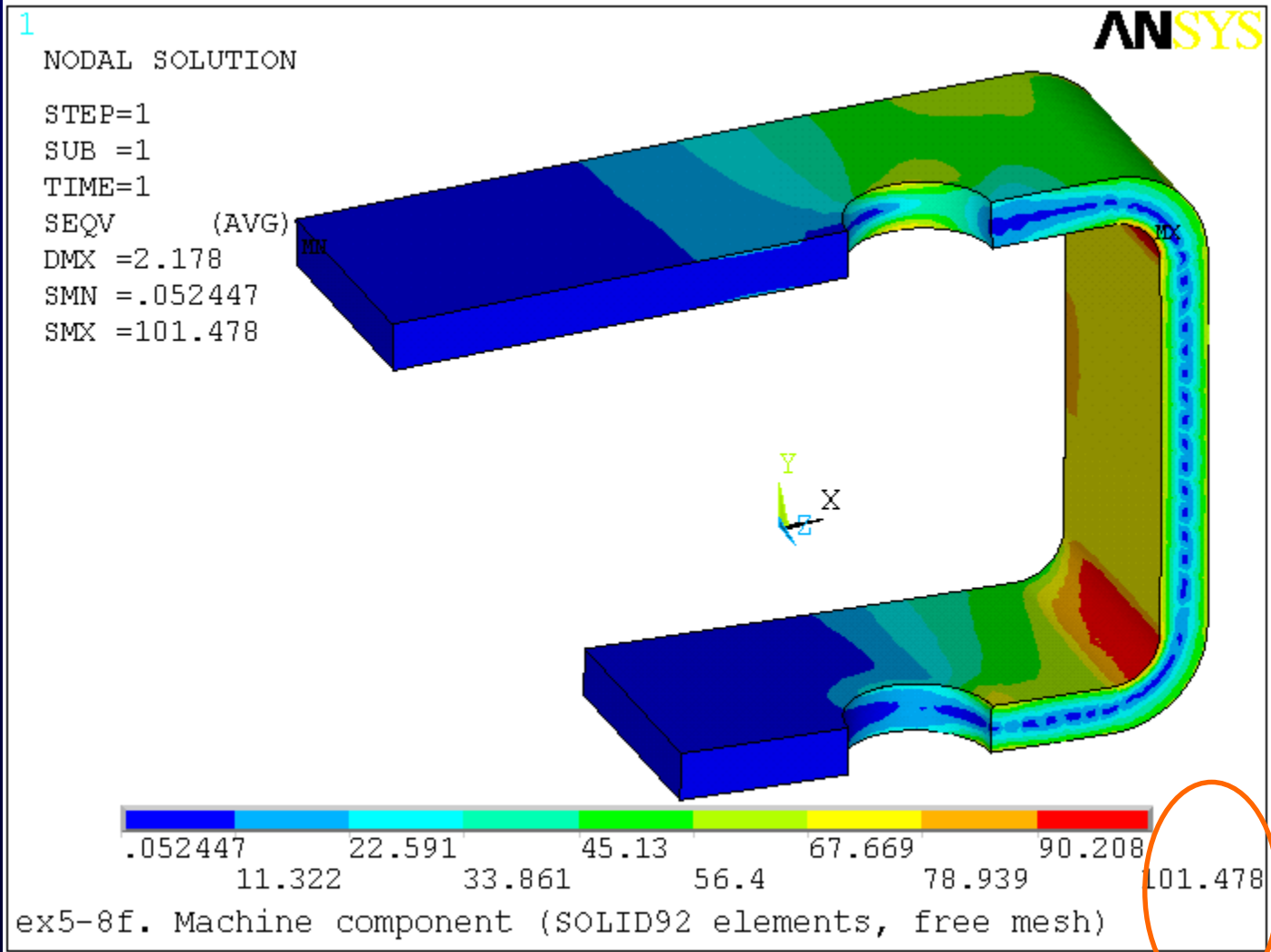

# SOLID187 計算結果(b)

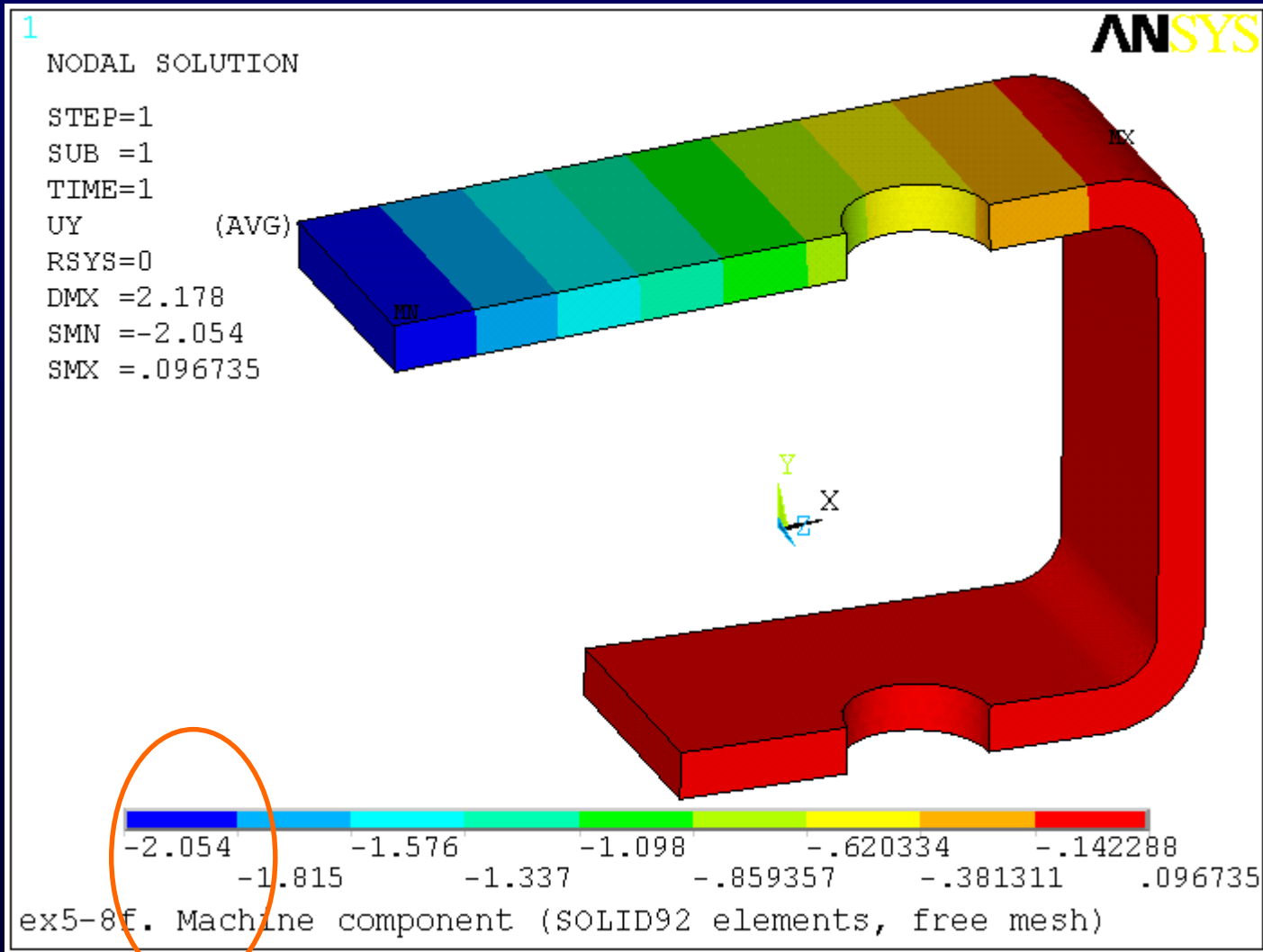

- **NSORT,S,EQV,0,0,,0**
- **PRNSOL,S,PRIN**
- 列出以下的主應力(S1、S2、S3)與von Mises應力值(SEQV)：

NODE	S1	S2	S3	SINT	SEQV
3199	-1.0752	-34.184	-113.69	112.62	100.25
3175	-0.40420	-33.317	-112.26	111.85	99.563
3234	-0.59514	-33.677	-112.41	111.81	99.484
3171	-0.60976	-33.630	-112.11	111.50	99.204

- 以上最大von Mises應力值(SEQV)為100.25MPa，與Case2圖畫出的最大應力101.478MPa稍不同且與Case2較接近。

- 若改為使用SOLID185線性4節點三角錐元素(退化元素)的自由網格，在ANSYS執行後的結果如下圖，為：A點(圓角R1)的最大等效應力 $\sigma_{eqv}=87.042\text{MPa}$ ，B點的最大y方向位移 $v=.1.048\text{mm}$ 。與Case2結果比較，SOLID45三角錐元素的應力值誤差為13.14%，而位移誤差則高達49%。以上誤差來源為：SOLID185線性4節點三角錐元素，其元素剛性過高。ANSYS手冊不建議使用者採用SOLID45線性4節點三角錐元素(退化元素)來做自由網格，因為其誤差過大。

# SOLID185 三角錐元素計算結果(a)

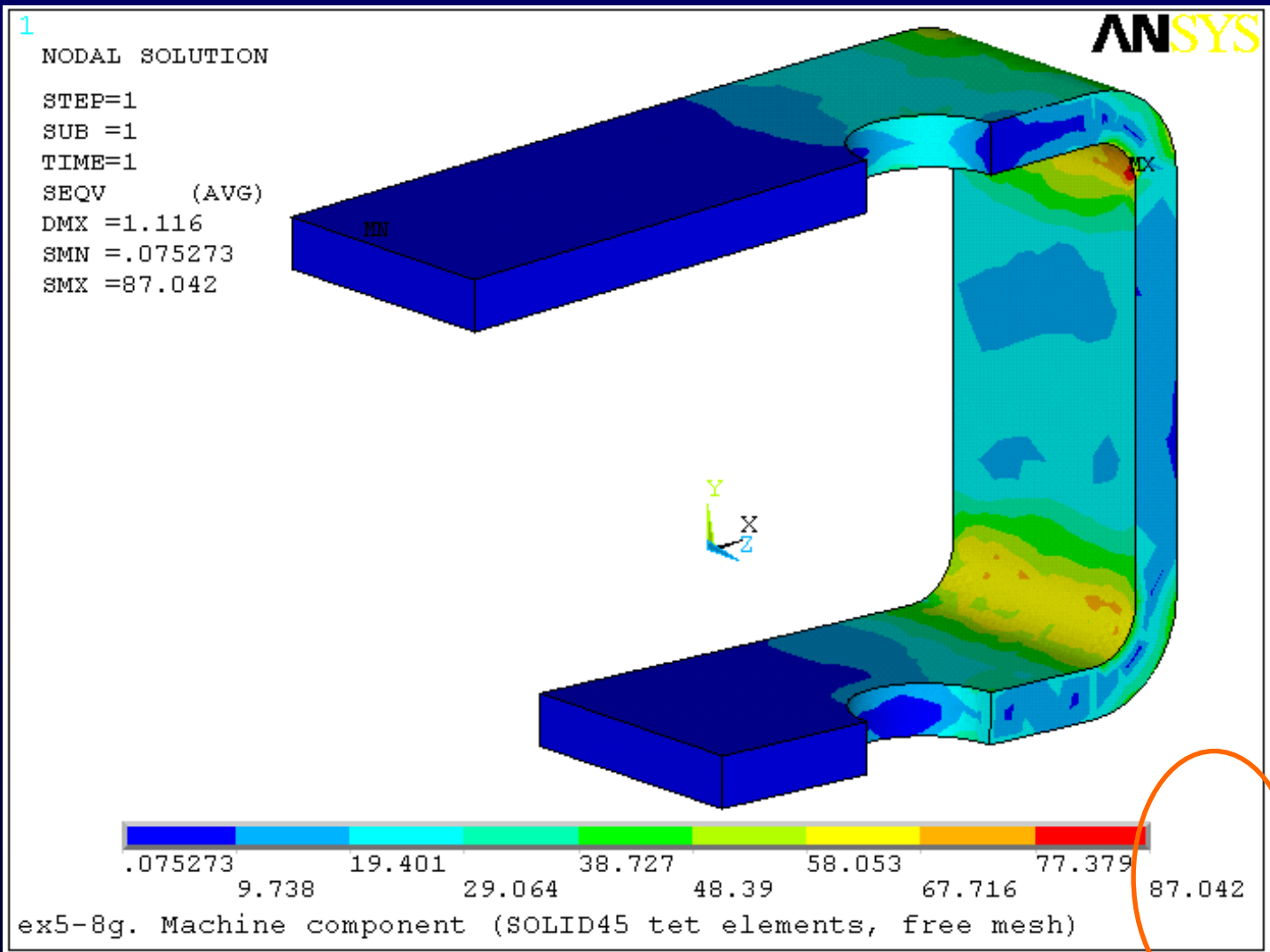

# SOLID185 三角錐元素計算結果(b)

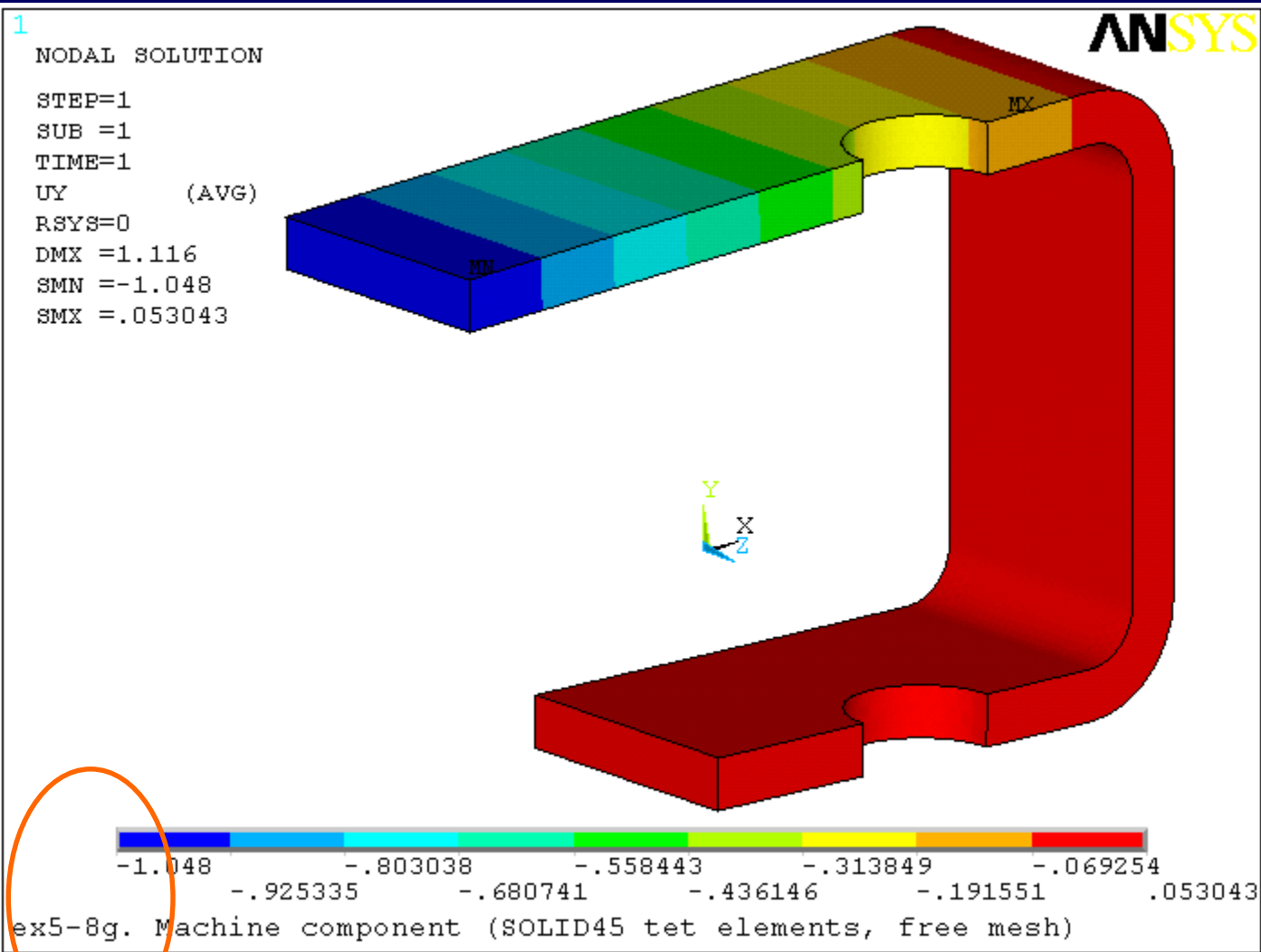

# Nonlinear structural analysis

- Geometric nonlinearities (large deformation)

Figure 8.2 A Fishing Rod Demonstrates Geometric Nonlinearity

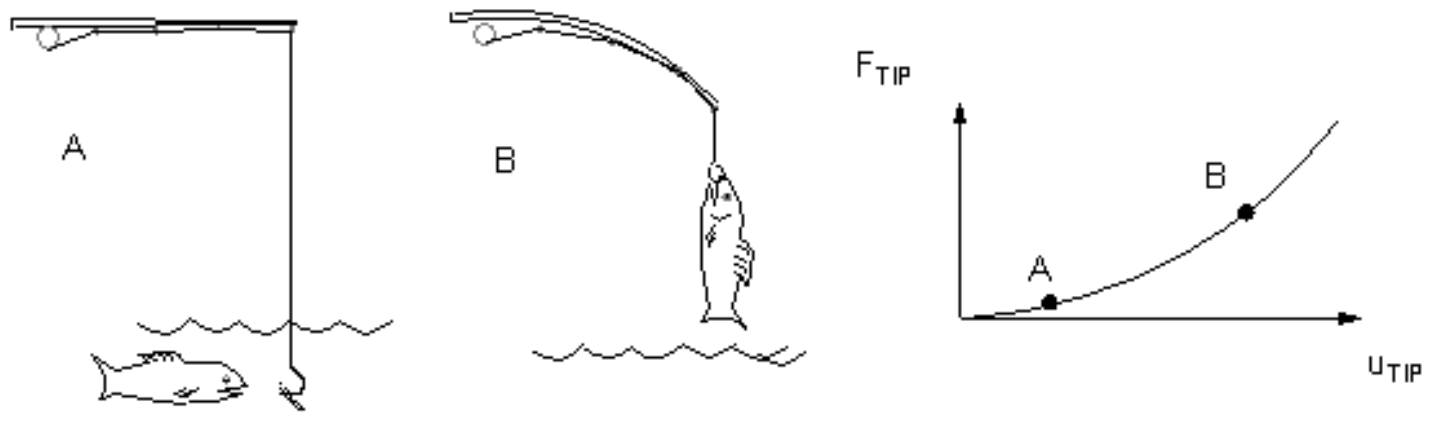

- Material nonlinearities
- Changing status (contact)

# Material nonlinearities

- 若應力分析範圍大於圖(b)中的降伏強度 $S_y$ ，因應力與應變呈曲線關係，便成為「材料非線性分析」，這和遵循虎克定律之線彈性分析完全不同。在結構分析中，若負荷過程的應力包含了彈性部分與超過 $S_y$ 的塑性部分，可稱為彈塑性(elasto-plastic)分析
- 下表列出了ANSYS材料非線性之模擬功能

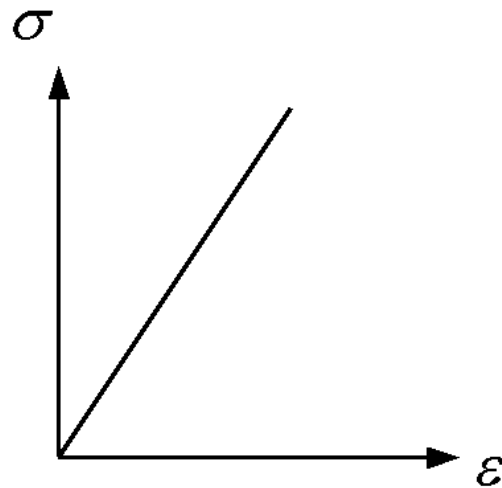

(a)

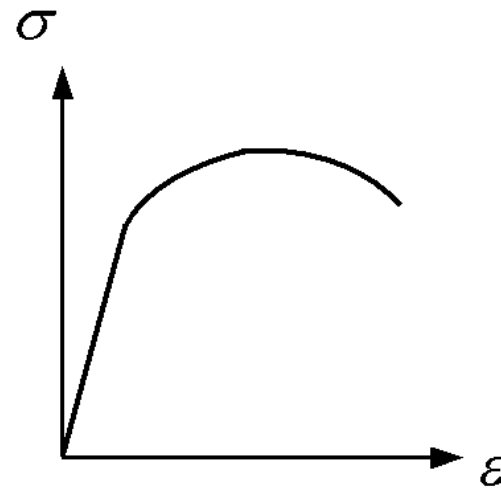

(b)

# Material nonlinearities

材料行為	變形型式	與應變率 (或時間) 之關係 (Rate dependency)	材料性質分類	材料模型 (Material laws)	
線性	彈性	無關 (Rate-independent)	Linear elastic	Hooke's law	
非線性	彈性	無關 (Rate-independent)	Hyperelastic	Mooney-Rivlin	
				Arruda-Boyce	
			Multilinear elastic	Blatz-Ko	
				Multilinear elastic	
	非彈性	無關 (Rate-independent)	無關 (Rate-independent)	Isotropic hardening plasticity	Bilinear isotropic
					Multilinear isotropic
					Voce's nonlinear isotropic
				Kinematic hardening plasticity	Anisotropic
					Bilinear kinematic
					Multilinear kinematic
				Combined kinematic and isotropic hardening plasticity	Chaboche
					Chaboche and bilinear isotropic
					Chaboche and multilinear isotropic
				Pressure-dependent plasticity	Chaboche and Voce's
					Druger-Prager
相關 (Rate-dependent)	相關 (Rate-dependent)	相關 (Rate-dependent)	Viscoplasticity	Creep	
				Anand	
			Combined creep and isotropic hardening plasticity	Creep and bilinear isotropic	
				Creep and multilinear isotropic	
				Creep and Voce's	

# Material nonlinearities-彈塑性分析

- 塑性力學(plasticity)所研究的對象，是延性材料在降伏後[圖應力  $> S_y$ ]所發生的塑性變形(plastic deformation)，這是屬於材料非線性分析的一種。由圖可看出結構受力過程包括了彈性與塑性變形，這類分析稱為彈塑性(elastoplastic)分析。
- 材料達到塑性後，其主要現象為產生永久變形與應變硬化(strain hardening)。
- 若材料達到塑性變形(應力  $> S_y$ )，當外力移除後將留下永久變形，圖中之  $\epsilon_p$  即為移除外力後所殘留之塑性應變(plastic strain)，且在許多情況下會有殘留應力(residual stress)存在於材料內部。

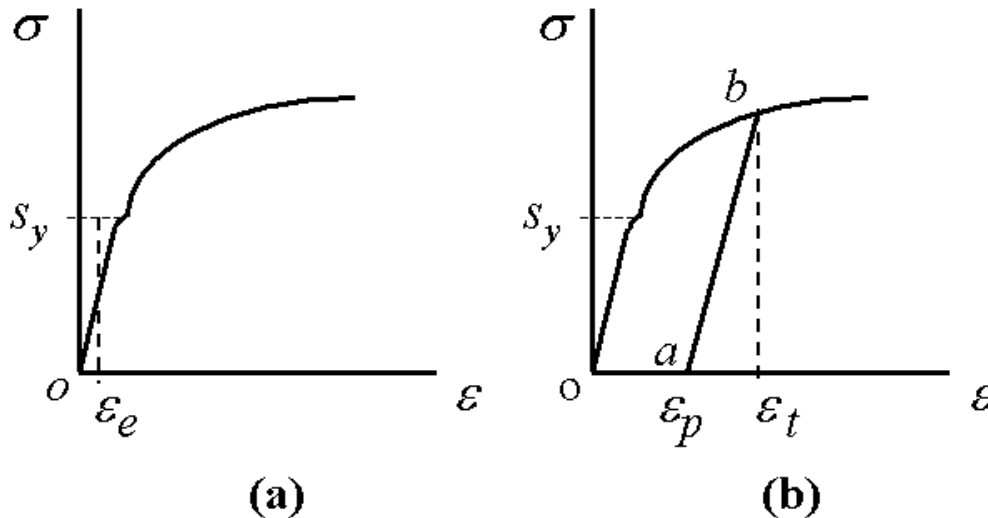

# Material nonlinearities-彈塑性分析

- 應變硬化的方式常見有兩類，為等向性硬化(isotropic hardening)與動態性硬化(kinematic hardening)，它們可由左圖來表示。等向性硬化模型是假設材料在各方向均同等硬化，此模型適用於單方向負荷問題。而動態性硬化是假設材料在一方向硬化，其反方向則會弱化，此模型考慮了如右圖之效應問題。

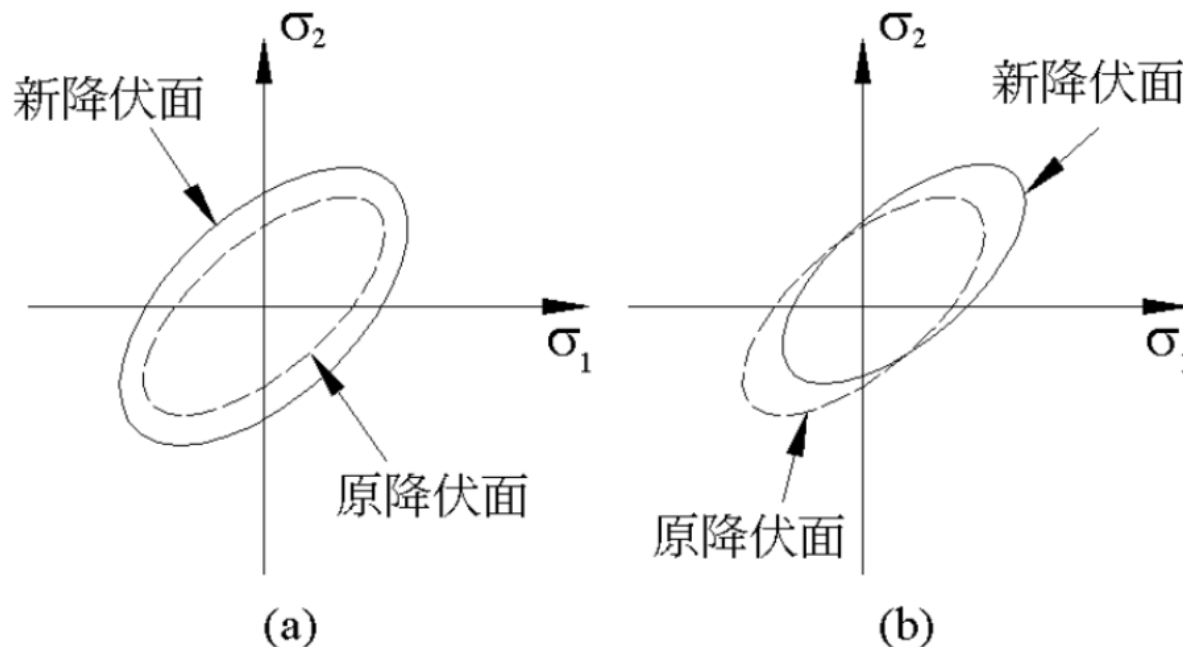

# Material nonlinearities-彈塑性分析

- 相對的在數學解析或有限元素分析上，有以下幾種應力應變曲線模式：**(1) 彈性—完全塑性(elastic perfectly-plastic)**；**(2) 雙線性(bi-linear)**；**(3) 多線段(multi-linear)**；**(4) 塑性曲線**，以上四種曲線如圖所示

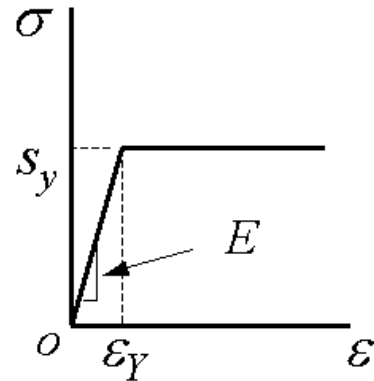

(a)

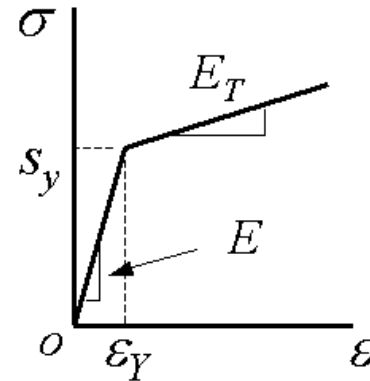

(b)

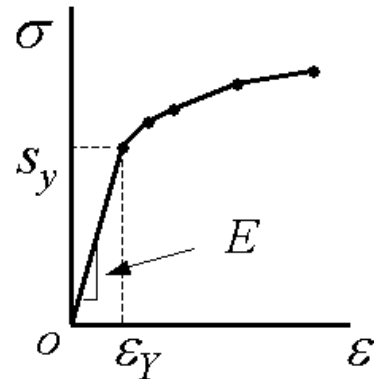

(c)

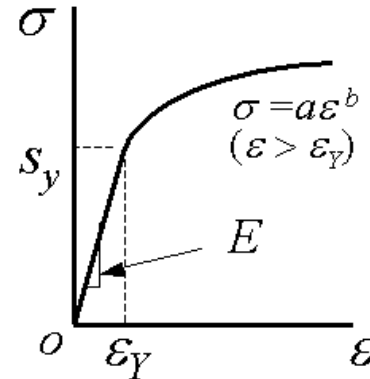

(d)

# Introduction of ANSYS-solution

## ■ Load Steps,

- In a linear static or steady-state analysis, you can use different load steps to apply different sets of loads--wind load in the first load step, gravity load in the second load step, both loads and a different support condition in the third load step, and so on.
- In a transient analysis, multiple load steps apply different segments of the load history curve.

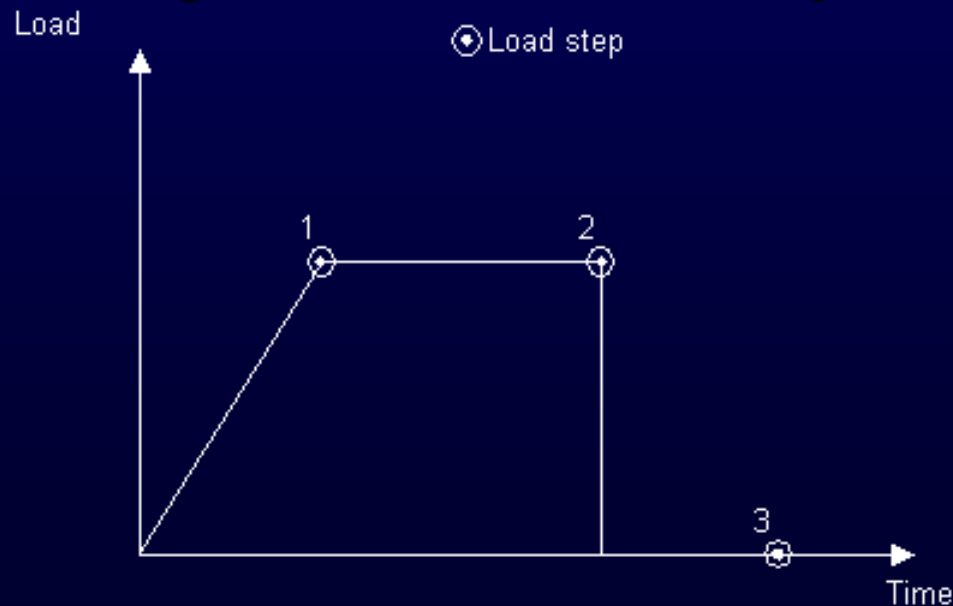

# Introduction of ANSYS-solution

## ■ Substeps

- **Substeps** are points within a load step at which solutions are calculated. You use them for different reasons:
  - ◆ In a nonlinear static or steady-state analysis, use substeps to apply the loads gradually so that an accurate solution can be obtained.
  - ◆ In a linear or nonlinear transient analysis, use substeps to satisfy transient time integration rules

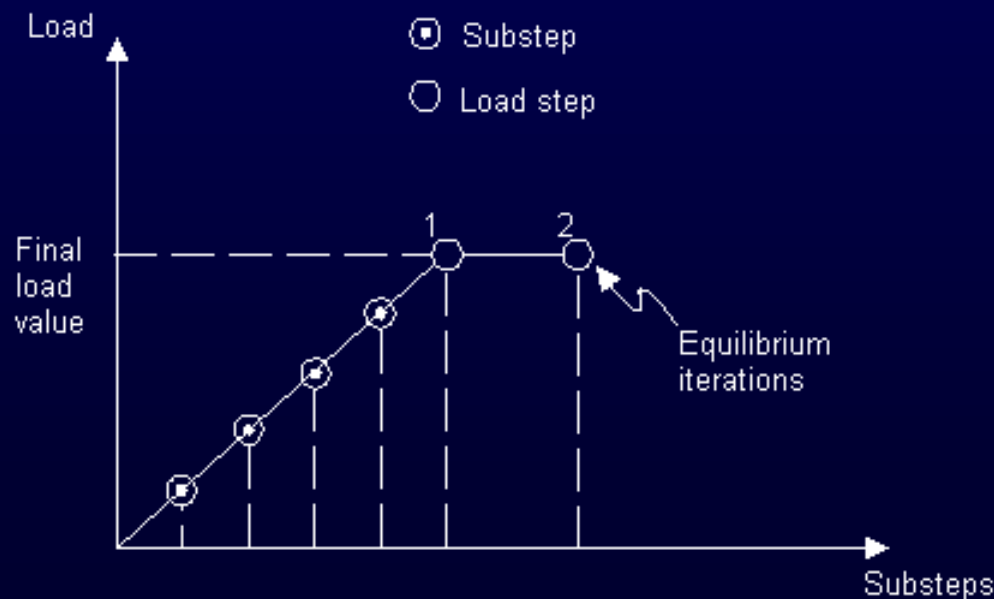

## **Nonlinear material property example: (Ex 11)**

- 長60mm寬6mm高10mm， $E=200\text{GPa}$ ，Poisson's ratio=0.3，同時假設材料為彈塑性材料(perfectly elastic-plastic material)，應力應變關係圖如下圖，降服強度=100MPa，slope=0. 試求出塑性區域位置及殘留應力有多大

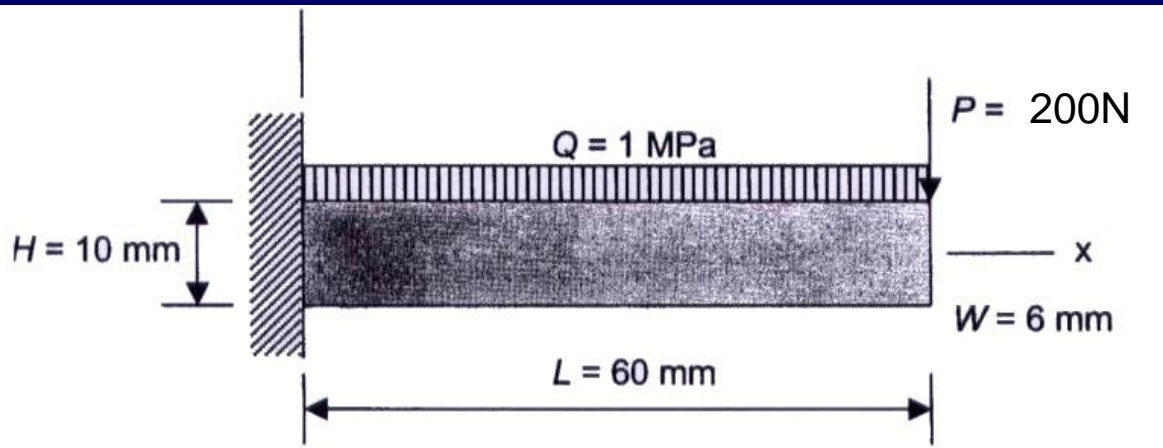
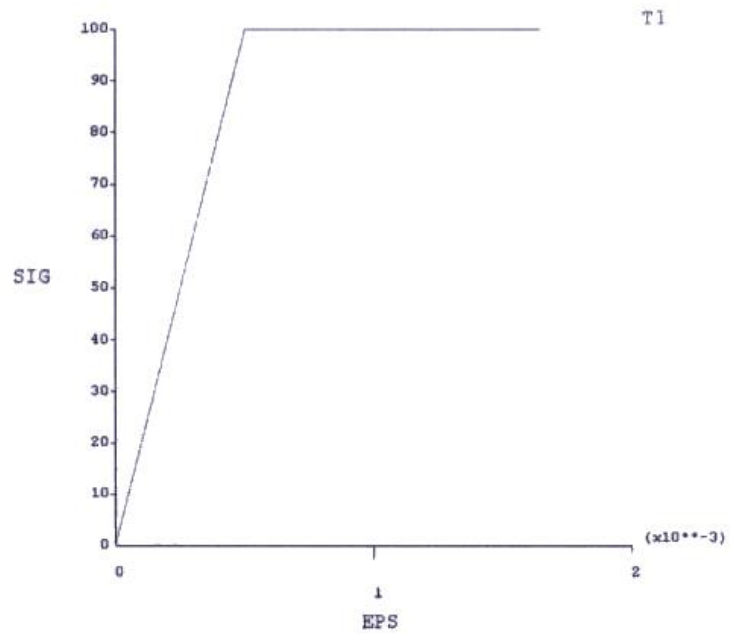

Figure 3-11 懸臂樑結構

BKIN Table For Material 1



# Ex12:含圓孔薄板分析

- 將針對文獻中的一個含實驗例題，以ANSYS來分析比較。本例題與數據是採用自文獻，為一含圓孔平板之彈塑性應力分析。如圖之鋁板，長寬為900×450mm，厚2mm，中央含一直徑225mm之圓孔，受集中力 $P=147000\text{N}$ 。鋁板材料性質為：楊氏模數 $E=71200\text{MPa}$ ，普松比 $\nu=0.31$ ，降伏強度 $S_y=260\text{MPa}$ ，真應力應變曲線原為一實際曲線，經MISO之多直線段簡化且輸入ANSYS後，如圖所示。本例分析單位：mm、N、MPa

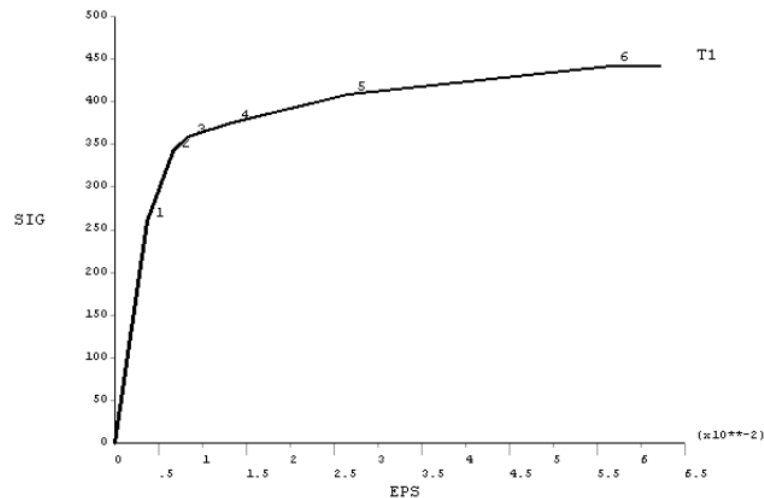
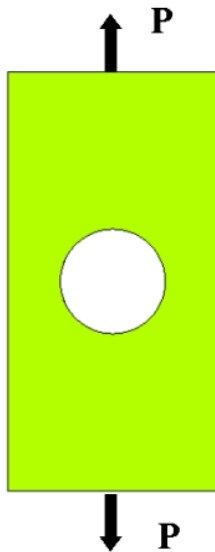

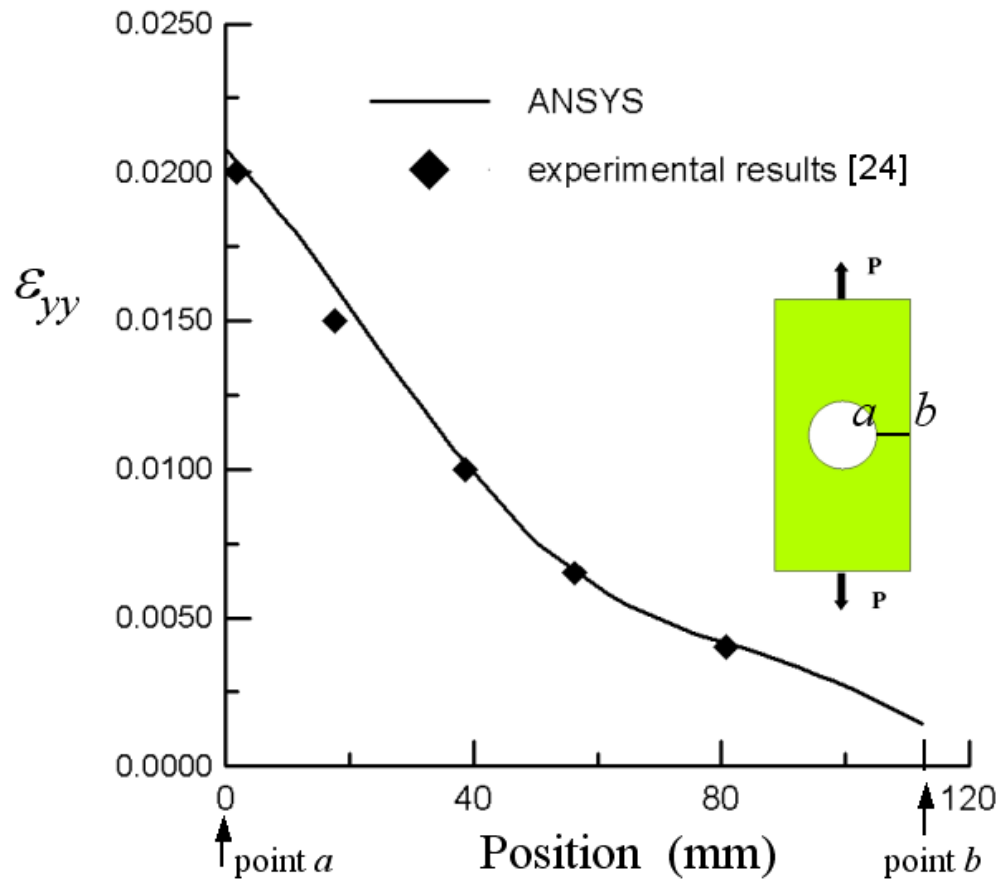
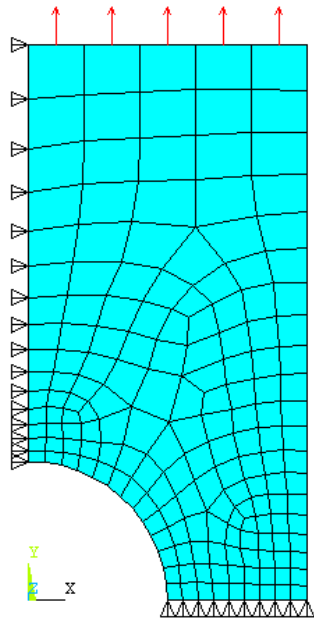

圖為ANSYS總應變 $\epsilon_{yy}$ 計算結果與文獻中之實驗值比較，兩者分析結果十分接近。

# von Mises 等效應力(SEQV)分布(MPa)

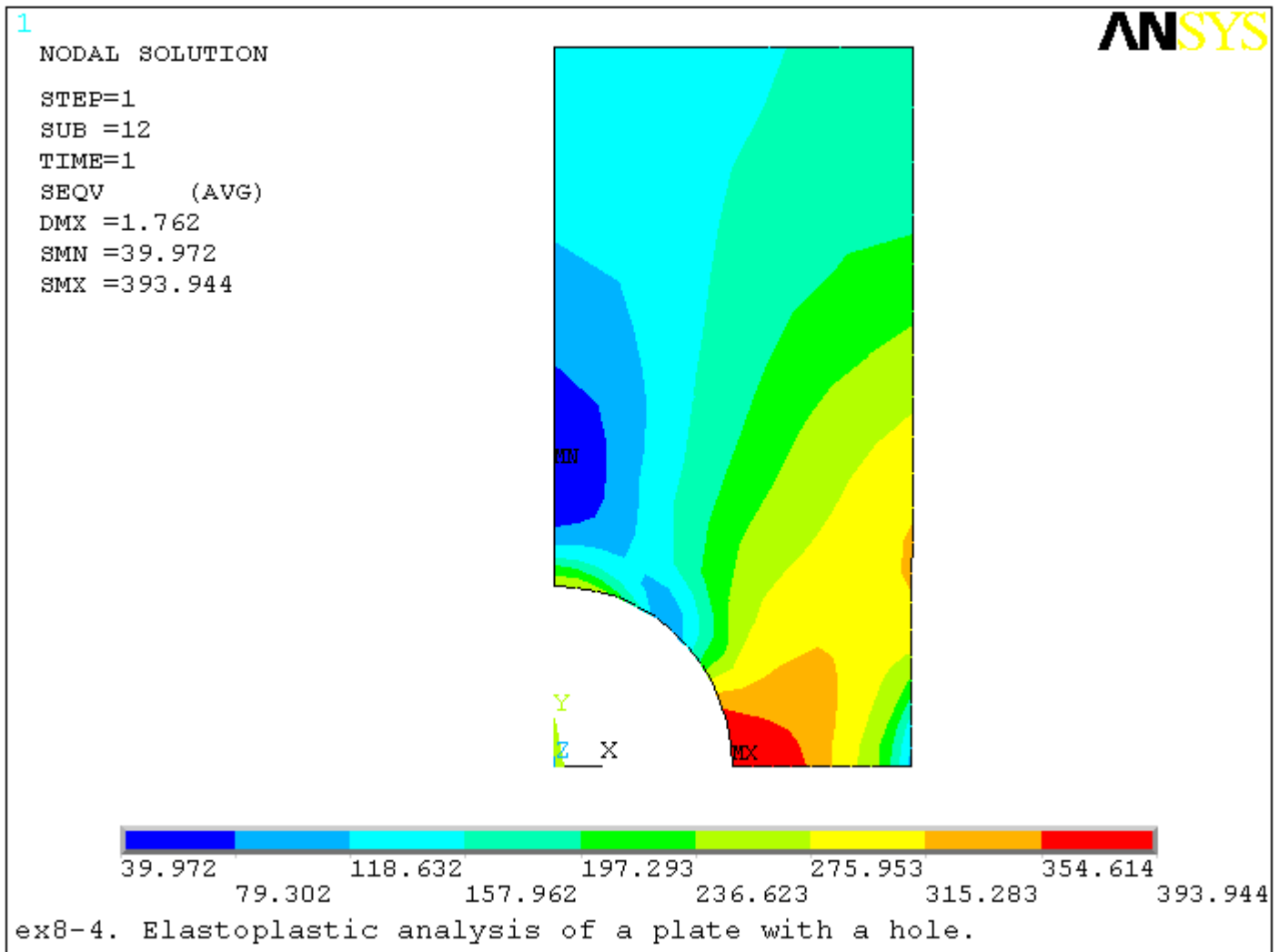

# y方向總應變 $\epsilon_{yy}$ (EPTOY)分布

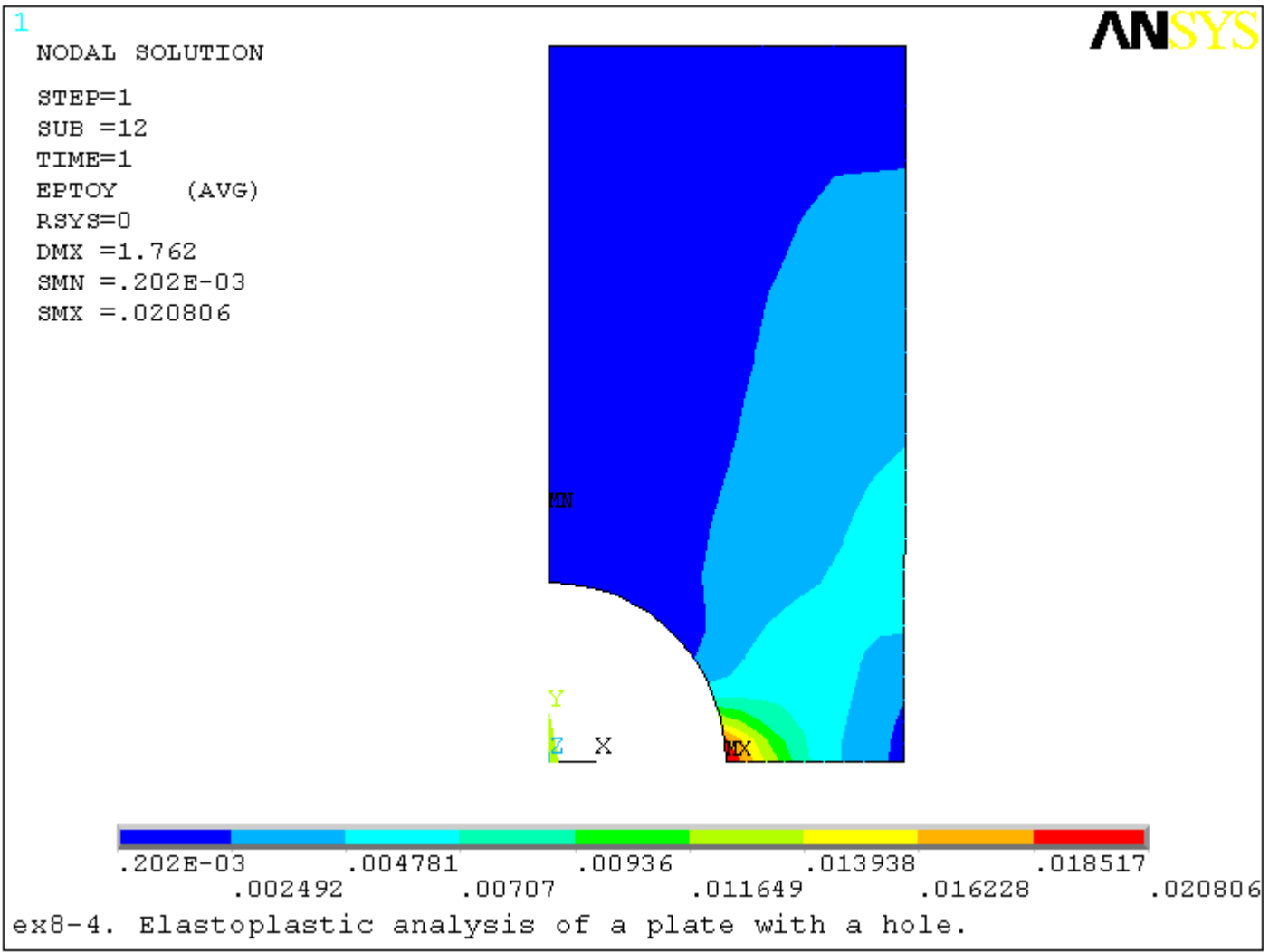

# y方向塑性應變 $\epsilon_{pyy}$ (EPPLY)分布

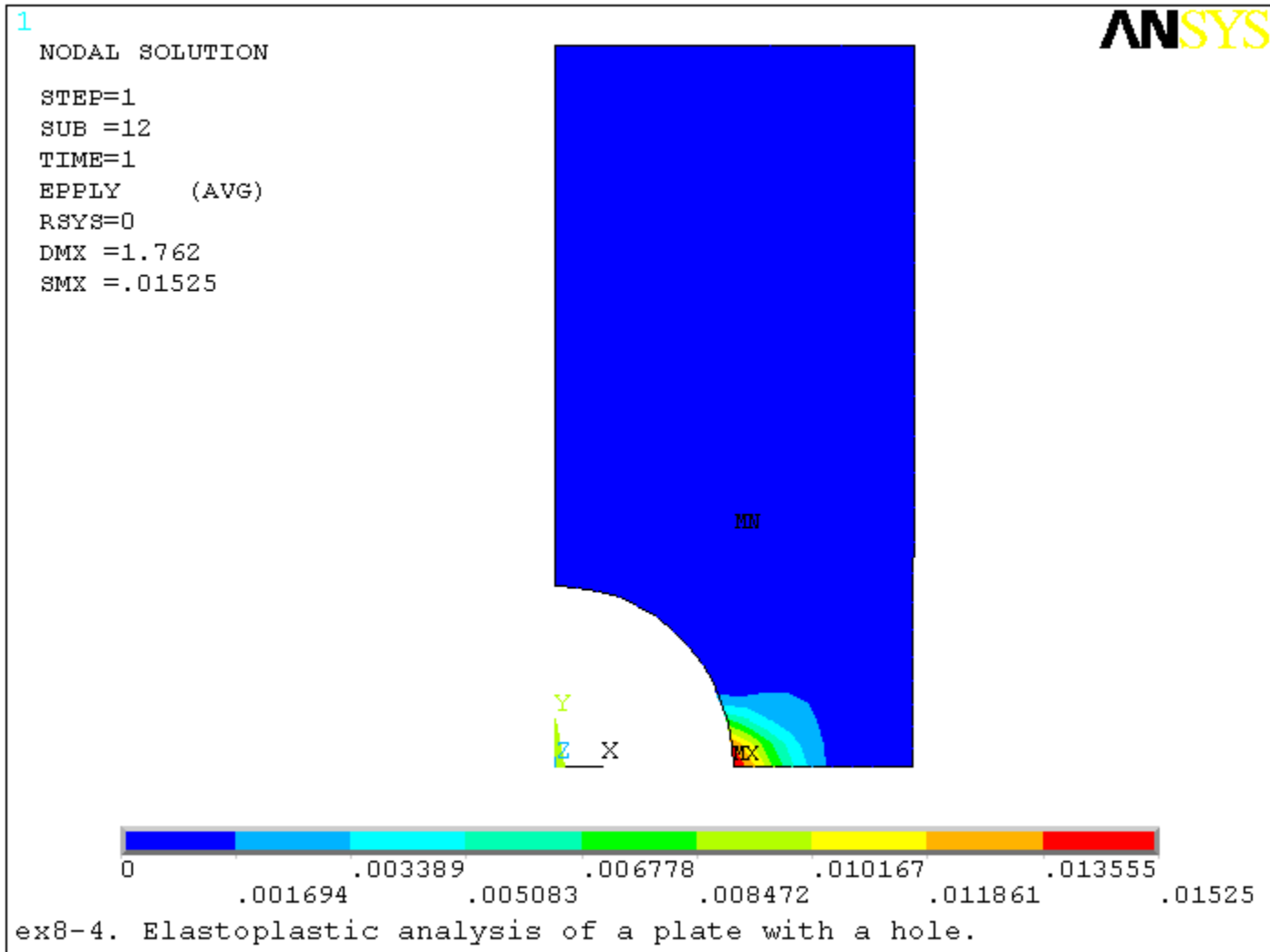

# Material nonlinearities

材料行為	變形型式	與應變率 (或時間) 之關係 (Rate dependency)	材料性質分類	材料模型 (Material laws)	
線性	彈性	無關 (Rate-independent)	Linear elastic	Hooke's law	
非線性	彈性	無關 (Rate-independent)	Hyperelastic	Mooney-Rivlin	
				Arruda-Boyce	
		相關 (Rate-dependent)	Viscoelasticity	Blatz-Ko	
				Multilinear elastic	
	非彈性	無關 (Rate-independent)	Isotropic hardening plasticity	Multilinear elastic	
				Kinematic hardening plasticity	Viscoelasticity
					Combined kinematic and isotropic hardening plasticity
			Multilinear isotropic		
			Voce's nonlinear isotropic		
			相關 (Rate-dependent)	Viscoplasticity	Anisotropic
					Combined creep and isotropic hardening plasticity
		Creep		Multilinear kinematic	
				Creep and bilinear isotropic	Chaboche
			Creep and multilinear isotropic		Chaboche and bilinear isotropic
		Creep and Voce's			Chaboche and multilinear isotropic
Creep and Voce's	Chaboche and Voce's				
	Creep and Voce's		Druger-Prager		
		Creep and Voce's	Anand		
Creep and Voce's			Creep and bilinear isotropic		
	Creep and Voce's		Creep and multilinear isotropic		
		Creep and Voce's	Creep and Voce's		

# Material nonlinearities-彈簧片分析 (Ex 13)

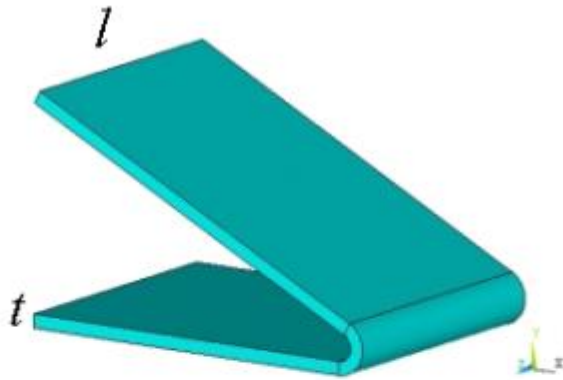

(a)

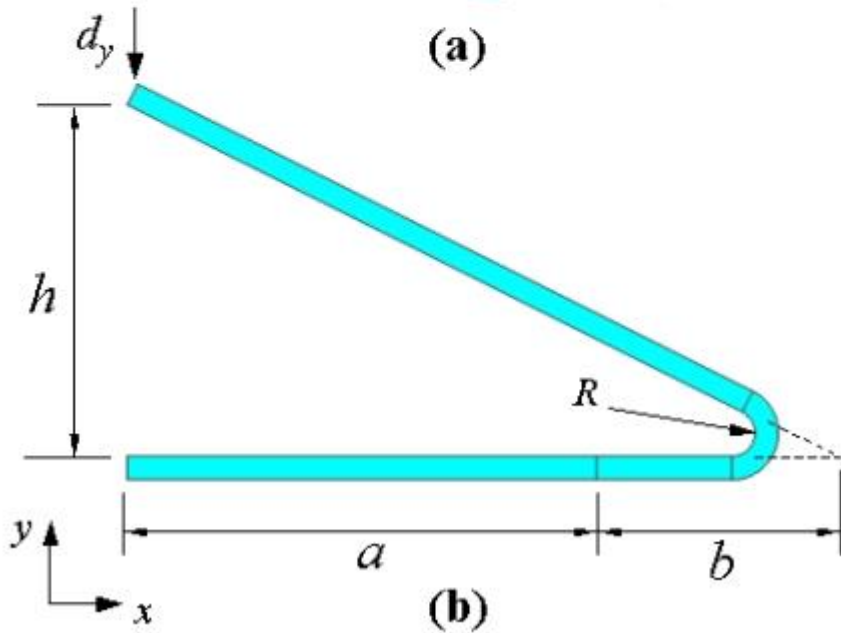
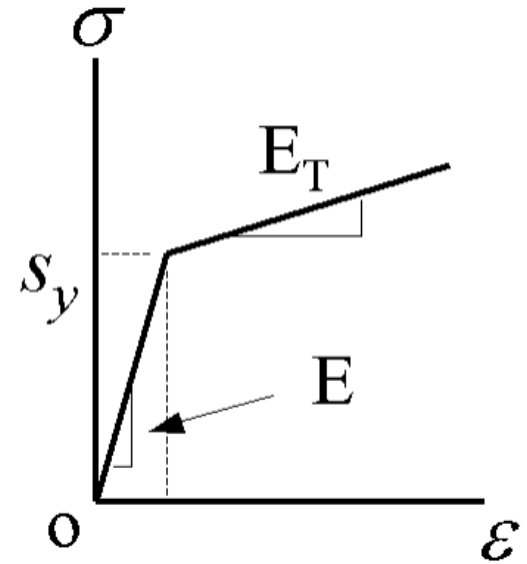

(b)

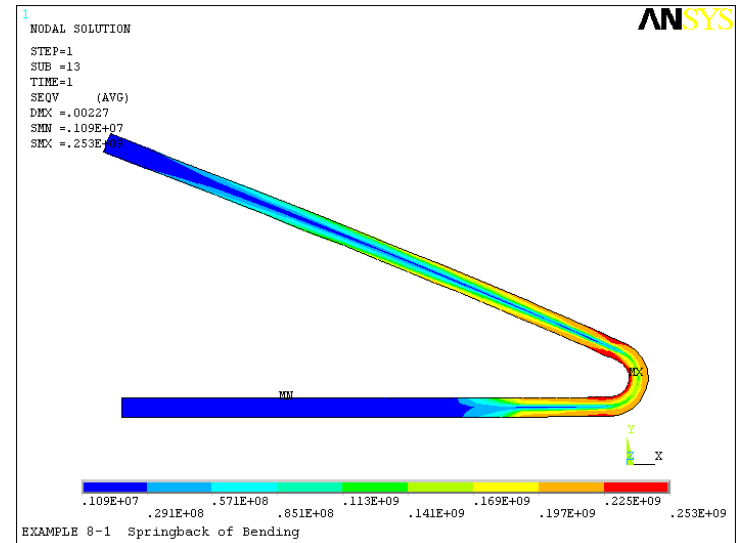

# Adv. solution example: (Ex 13)

- 本例題目如圖所示類似彈簧片的結構，其尺寸為 $l=0.02\text{m}$ ， $h=0.015\text{m}$ ， $a=0.02\text{m}$ ， $b=0.01\text{m}$ ，圓角 $R=0.001\text{m}$ ，厚度 $t=0.001\text{m}$ ，材料之楊氏模數 $E=210000 \times 10^6\text{Pa}$ ，其真應力應變曲線如圖之BISO曲線， $E_T=30000 \times 10^6\text{Pa}$ ，普松比 $\nu=0.3$ ，降伏強度 $S_y=200 \times 10^6\text{Pa}$ 。

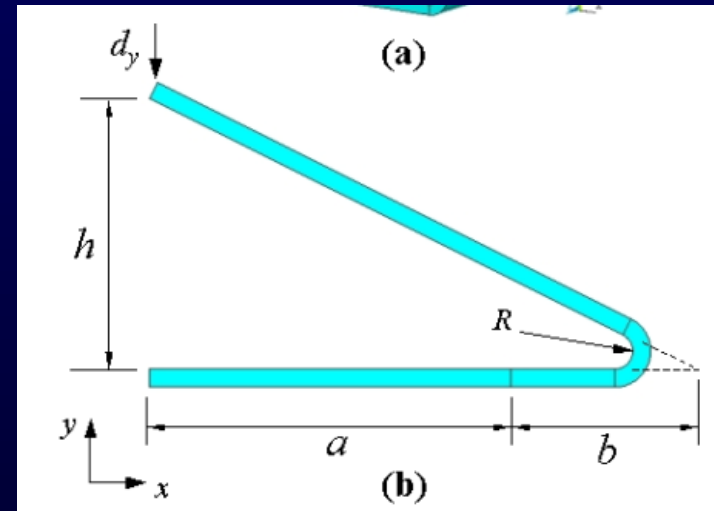
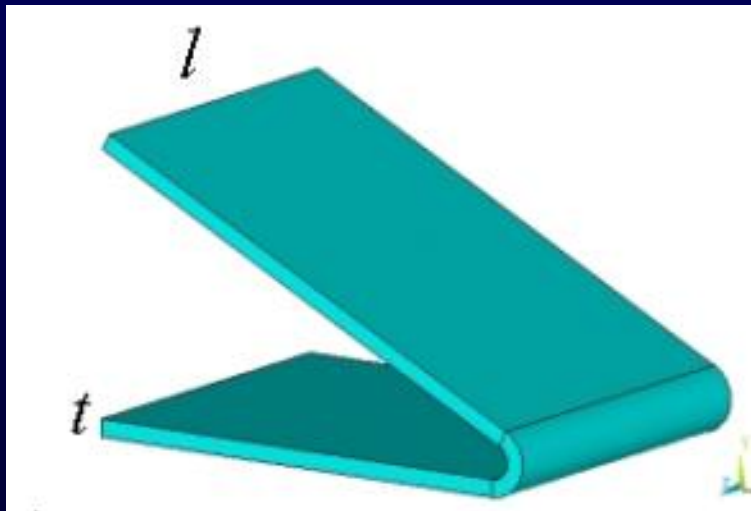

# Adv. solution example: (Ex 13)

- 邊界條件如圖，長度 $a$ 之底面部分全部拘束固定。分析目標：如圖，當給定之 $y$ 方向位移 $d_y = -0.002\text{m}$ 時，該結構若有塑性變形，求出移除負荷後的殘留變形，分析單位：m、N、Pa。

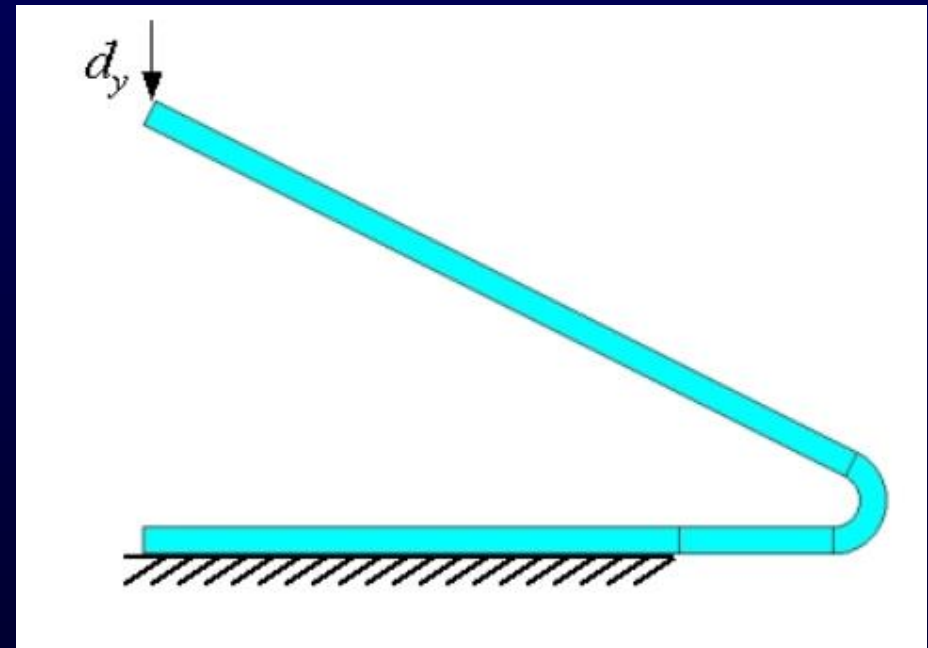
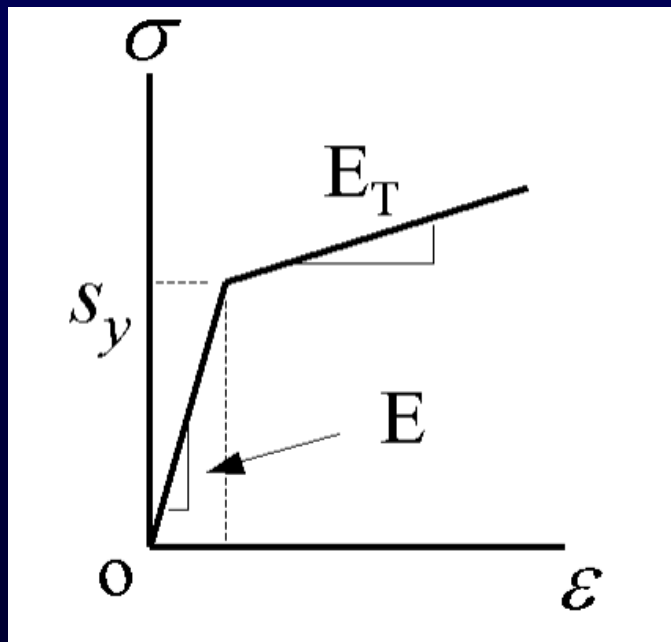

# Adv. solution example: (Ex 13)

## ■ Results

## ■ MainMenu→GeneralPostproc→ResultsSummary

```
***** INDEX OF DATA SETS ON RESULTS FILE *****
```

SET	TIME/FREQ	LOAD STEP	SUBSTEP	CUMULATIVE
1	0.33333E-01	1	1	2
2	0.66667E-01	1	2	3
3	0.11667	1	3	4
4	0.19167	1	4	5
5	0.29167	1	5	6
6	0.39167	1	6	7
7	0.49167	1	7	8
8	0.59167	1	8	10
9	0.69167	1	9	12
10	0.79167	1	10	14
11	0.89167	1	11	16
12	0.94583	1	12	17
13	1.0000	1	13	18

# Adv. solution example: (Ex 13)

- 由圖中可發現彎角部分von Mises等效應力已超過降伏強度 200MPa( $0.2 \times 10^9$ Pa) , 即發生塑性變形 , 而最高等效應力為 253MPa

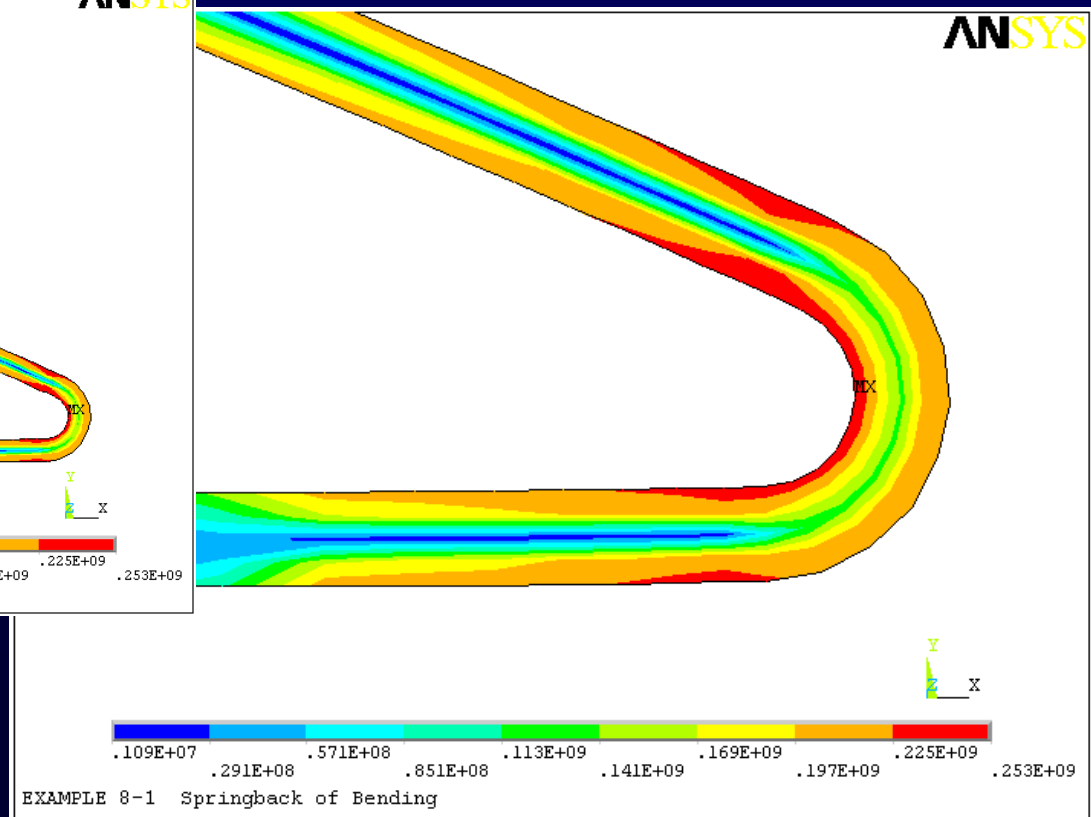
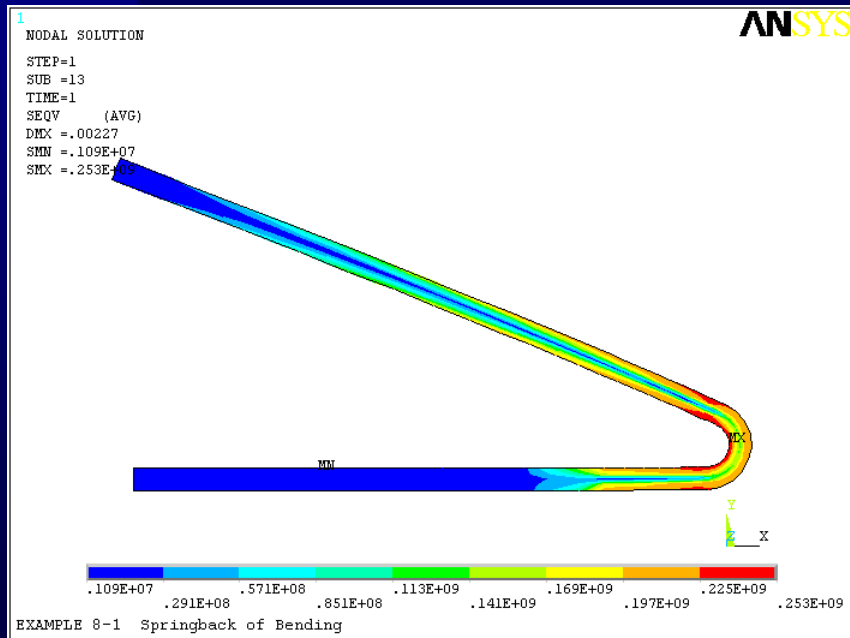

# Adv. solution example: (Ex 13)

## ■ 總應變(彈性+塑性)

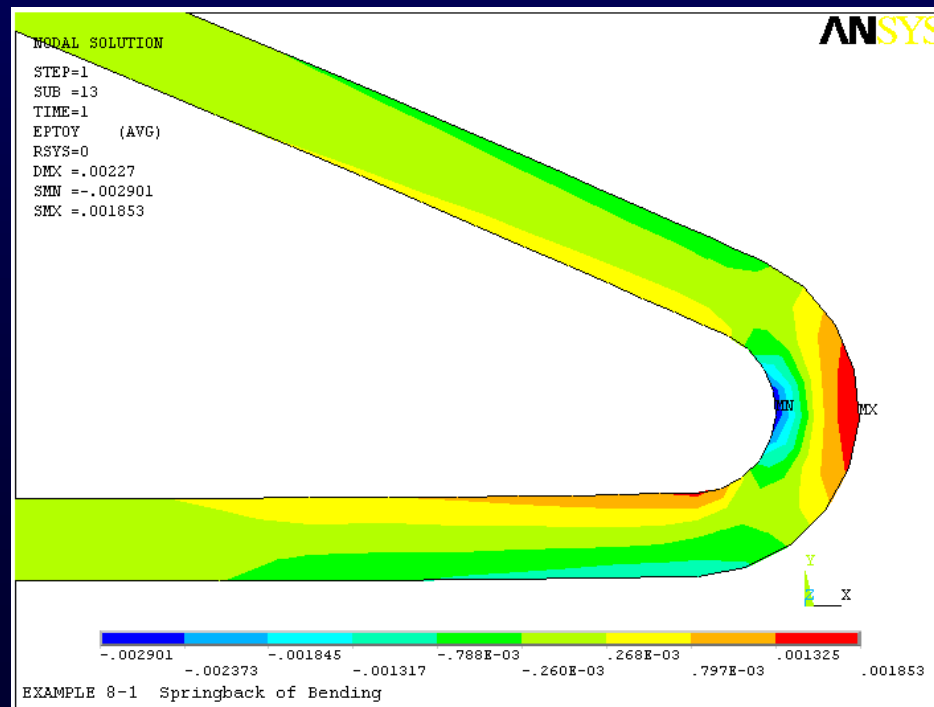
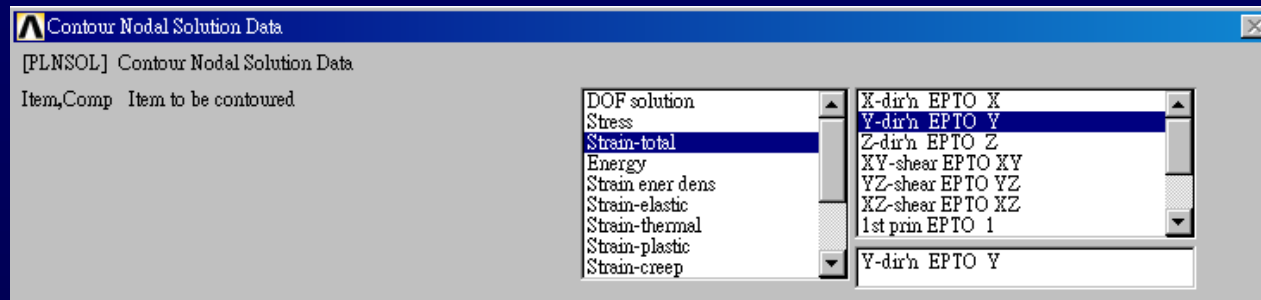

**ANSYS** Read Results by Load Step Number

[SET] [SUBSET] [APPEND]

Read results for: Entire model

LSTEP Load step number: 1

SESTEP Substep number: 4

FACT Scale factor: 1

OK Cancel Help

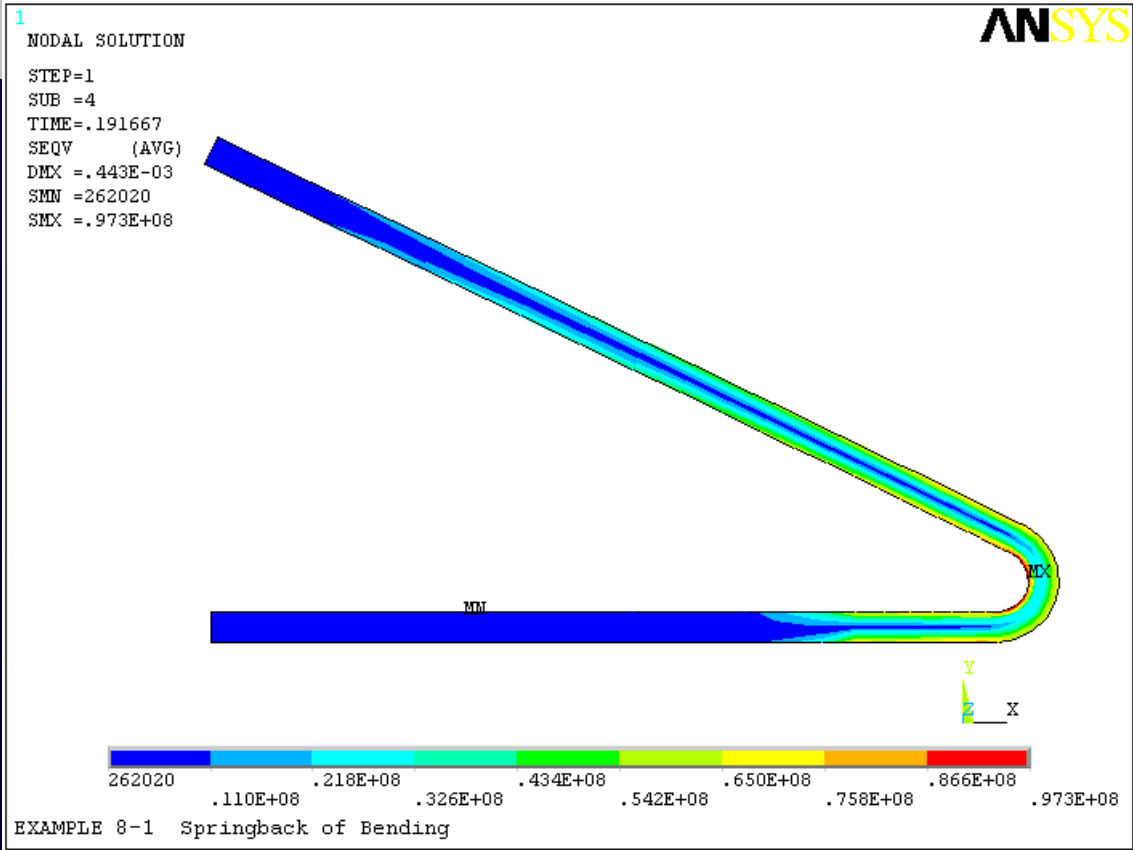

# Contact Problem

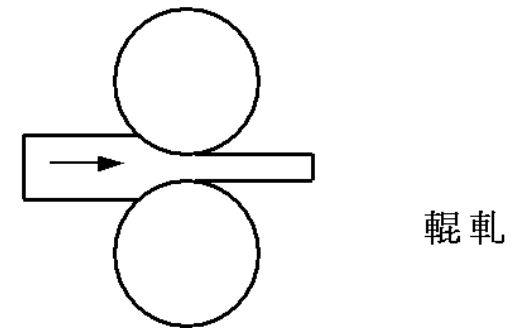
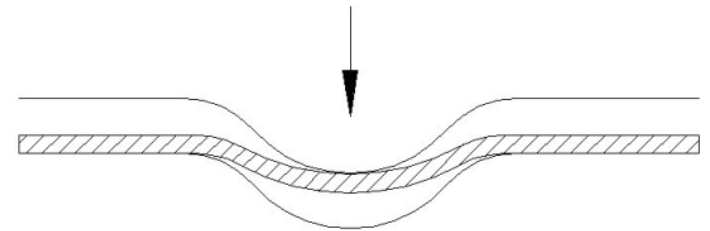
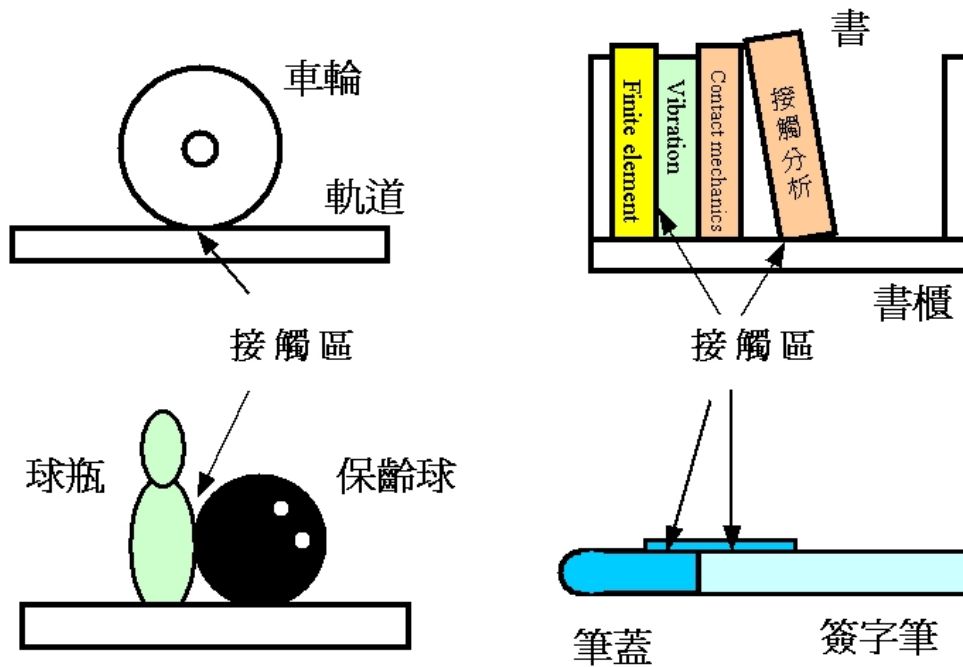

機械加工製程之接觸問題(塑性變形)

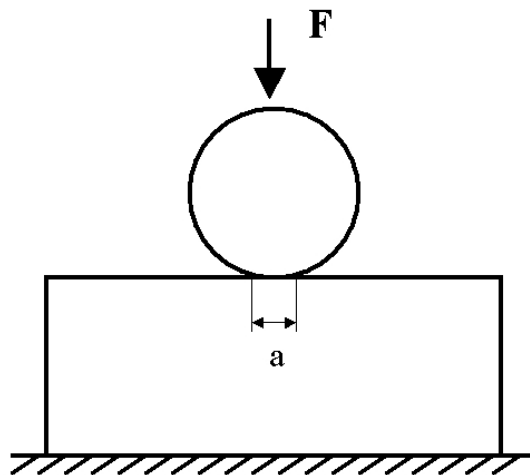

# ANSYS 之接觸元素與觀念

- 有限元素接觸分析是於物體之間的「接觸面」上加入了「非貫穿 (non-penetration)」條件。以下圖之兩物體接觸為例，首先須將  $S_a$  和  $S_b$  兩個面定義為「接觸面」，下令兩接觸面不可貫穿，如此一來，只要圓形物體受力變形，便可透過兩接觸面  $S_a$  和  $S_b$  將力量傳至矩形物體，使得矩形物體也跟著變形，即完成了接觸分析。
- ANSYS 是利用接觸元素 (contact elements) 來模擬接觸面，只要接觸區域的接觸元素一被建立，ANSYS 於計算時就會考慮到接觸條件

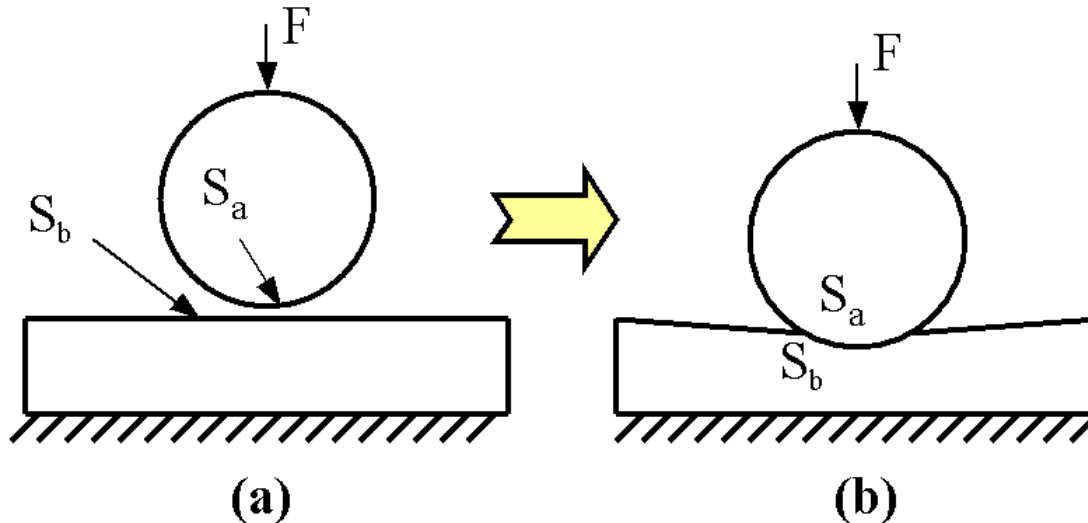

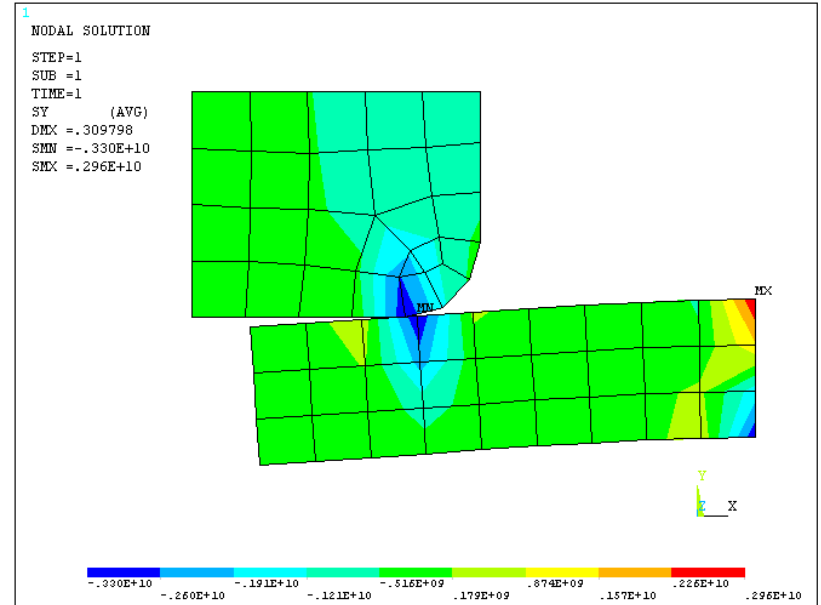
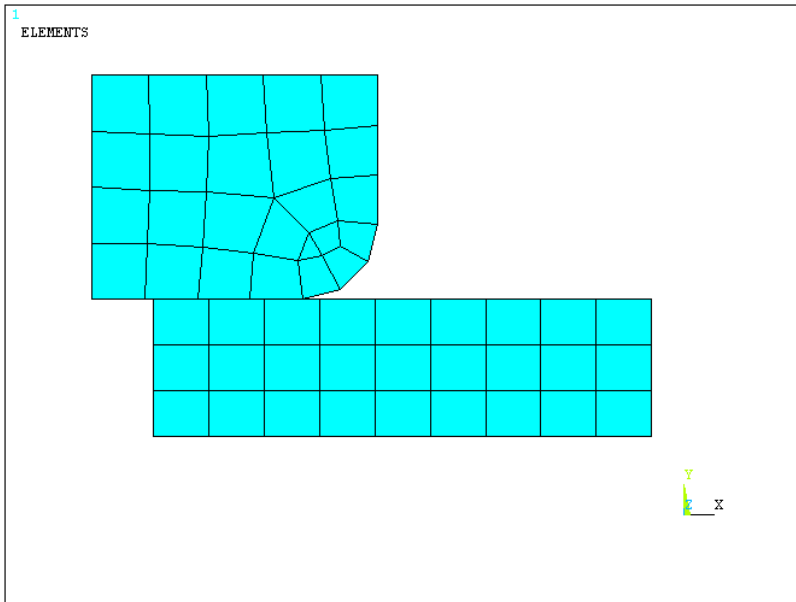

合理之接觸分析結果

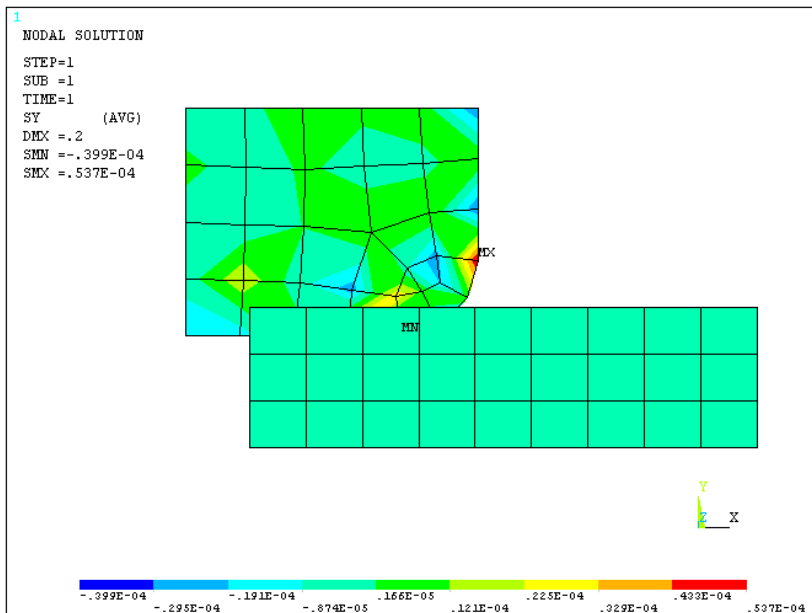

不合理之接觸分析結果  
(未建立接觸元素)

# Contact element type

- ANSYS提供了三大類接觸元素，它們為點對點(node-to-node)接觸元素、點對面(node-to-surface)接觸元素、面對面(surface-to-surface)接觸元素
- 面對面接觸元素建立

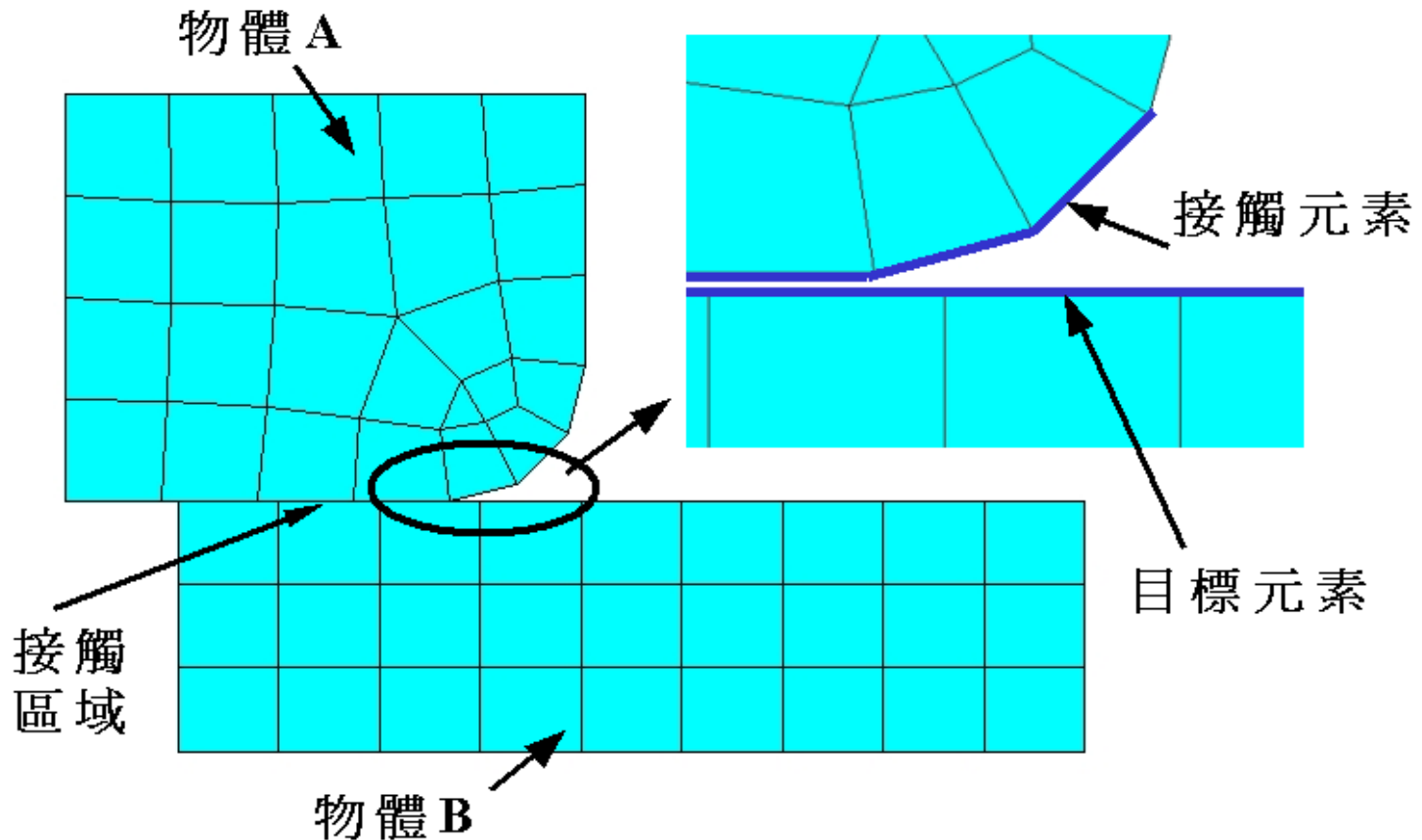

# Contact element type

## ■ Surface to surface

- 面對面接觸元素在使用上比較方便，且模擬接觸面的能力也較強
- 有關面對面接觸元素之接觸分析，可以分為兩大類：
  - ◆ 剛體對變形體(rigid-to-flexible) (R-F)
  - ◆ 變形體對變形體(flexible-to-flexible) (F-F)

■ 面對面接觸元素主要的觀念是「接觸對(contact pair)」，一個接觸對包括目標面(target surface)與接觸面(contact surface)，目標面是由目標元素(target elements)所構成，接觸面則由接觸元素(contact elements)所構成。

■ 目標元素有TARGE169以及TARGE170，接觸元素有CONTA171、CONTA172、CONTA173、CONTA174等，它們形狀如圖

■ 對於R-F接觸問題，目標元素必須建立為剛體，而接觸元素則附著於**變形體**。對於F-F接觸問題，兩變形體均可附著目標元素或接觸元素。

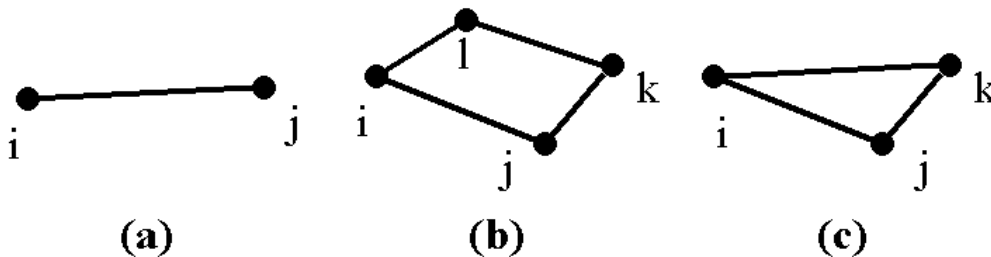

# 接觸對之接觸元素和目標元素建立原則

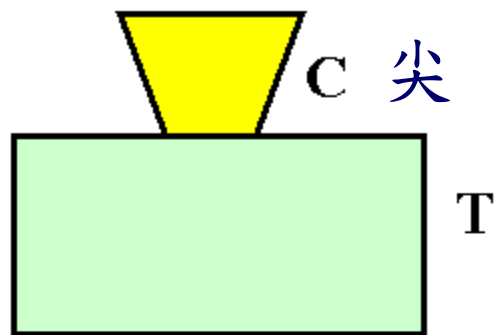

(a)

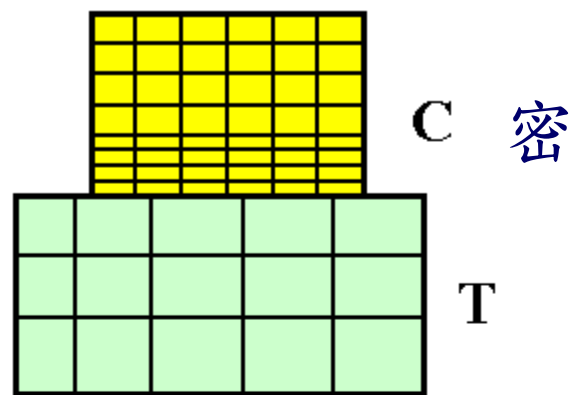

(b)

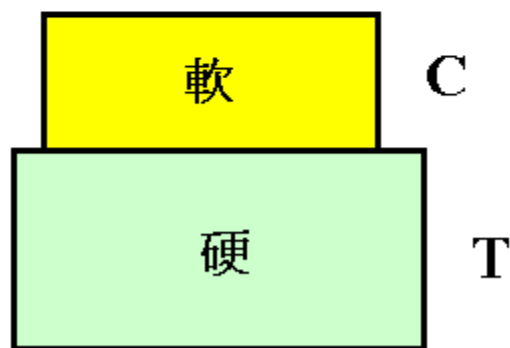

(c)

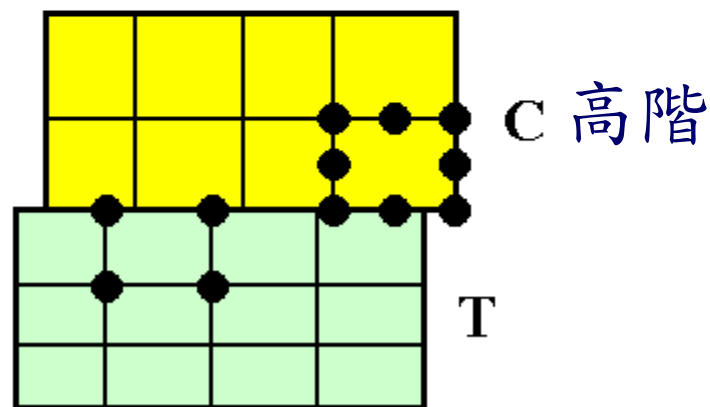

(d)

# 實常數與摩擦係數

- 關於接觸對之非貫穿接觸條件，是由目標元素和接觸元素所共用的實常數(real constants)來決定。
- 而經常設定的實常數有四個，分別為FKN、FTOLN、FKT、TAUMAX，摩擦係數則於材料係數中給定，其符號為MU。
- ANSYS面對面接觸元素內定之計算法則為augmented Lagrangian method，所以必須設定接觸剛度(contact stiffness) KN和貫穿公差(penetration tolerance)兩種計算常數，其在面對面接觸元素之實常數中，接觸剛度和貫穿公差分別使用FKN和FTOLN兩個實常數來設定。
- FKN之意義如圖所示，可想像兩物體有限元素模型接觸對之接觸面上，有一接觸彈簧(contact spring)，其彈簧係數即為接觸剛度，而接觸剛度KN定義為FKN乘以接觸體之剛度

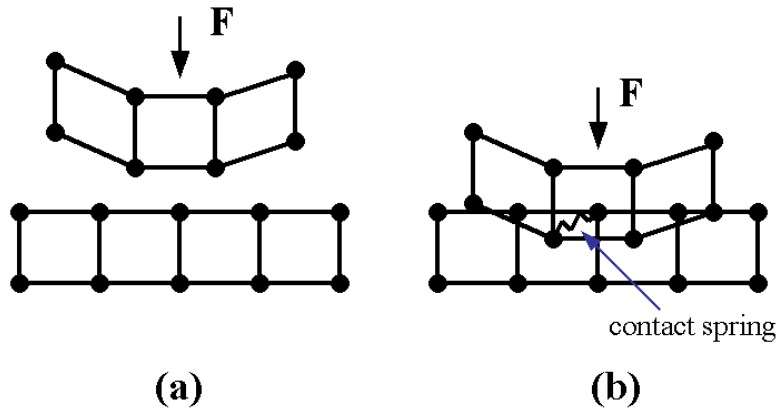

# FKN 經驗值

- 一般經驗值為：**(a)**針對有大體積變形(bulk deformation)之接觸狀況，例如圖上之兩物體接觸，先設定 $FKN=1$ ，再測試答案合理性；**(b)**若兩物體之接觸情形有彎曲(bending)狀況，例如圖下的彎曲接觸，先設定 $FKN=0.01\sim 0.1$ ，再測試答案合理性。

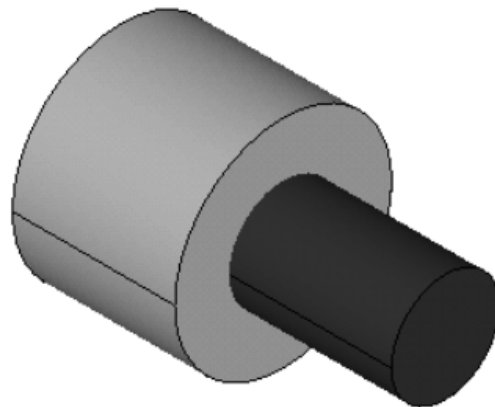
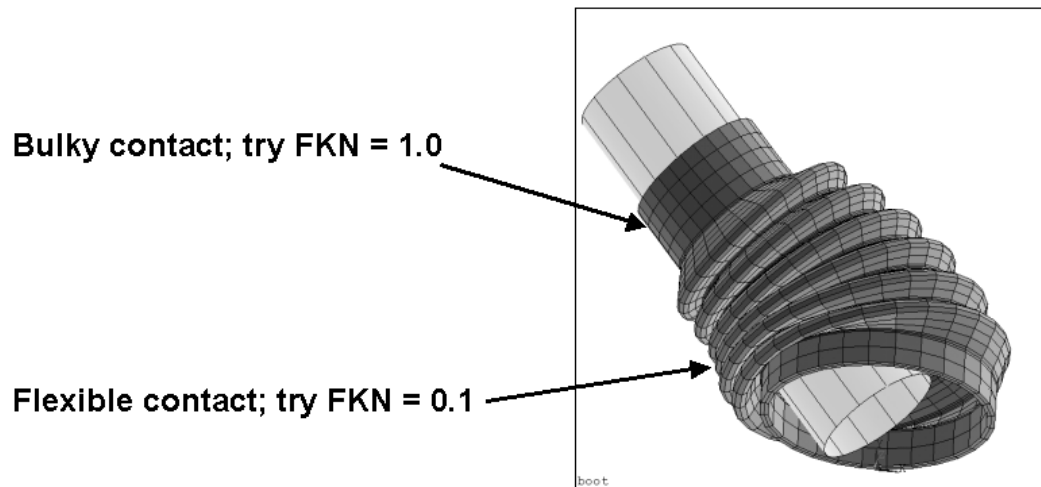

FKN	Max. SEQV
0.001	4,000
0.01	20,000
0.1	65,000
1	91,000
10	92,900
100	93,000

# FTOLN

- 在接觸面的計算上，兩物體接觸貫穿量必須小於貫穿公差才算是接觸
- 而FTOLN代表了貫穿公差之計算參數，ANSYS定義之貫穿公差為FTOLN乘以接觸面底下元素深度h，如圖所示。
- ANSYS以庫倫摩擦模型(Coulomb friction model)來模擬接觸摩擦現象，公式為：
- 越小的貫穿公差(越小的FTOLN)越接近實際接觸情況，過小的貫穿公差會造成數值無法收斂，FTOLN內定值為0.1(常設定範圍0.01-0.05)

$$\text{penetration tolerance} = (\text{FTOLN}) * h$$

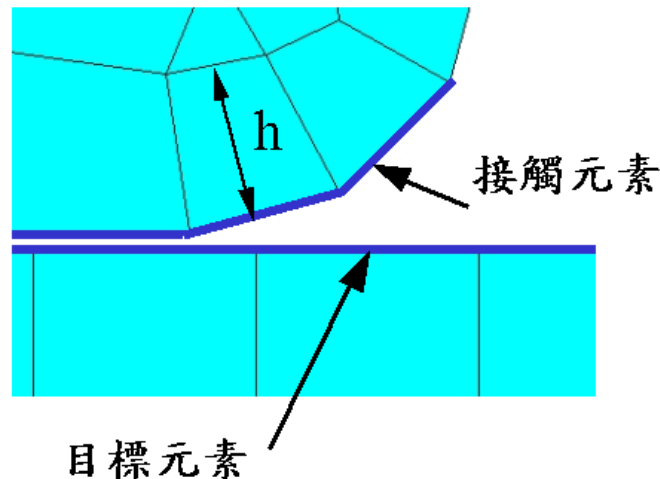

# Ex 14:3D Pin-hole contact problem

## Chapter 8. Contact Tutorial

### ■ Problem Description

- This is a 3-D analysis of a steel pin contacting a smooth pinhole in a block. Because of the inherent symmetry of the model, you will perform the analysis on a quarter symmetry model. You will define two different load steps. The objective of the first load step is to observe the interference fit stresses of the pin which is geometrically thicker than its pinhole. The objective of the second load step is to observe the stresses, contact pressures and reaction forces due to the motion of the pin being pulled out from the block.

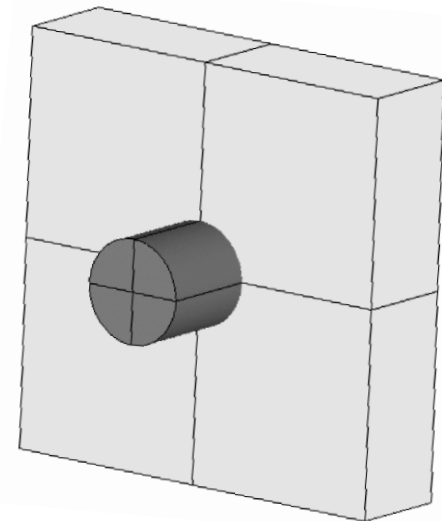

- **The dimensions of the model are as follows: PIN radius = 0.5 units, length = 2.5 units. BLOCK width = 4 units, length = 4 units, depth = 1 unit. PINHOLE radius = 0.49 units, depth = 1 unit. Both solids are made of structural steel (stiffness = 36e6, Poisson's ratio = 0.3) and are assumed to be flexible.**
- **Approach and Assumptions**
  - **A quarter symmetry model is appropriate to simulate the contact phenomena. You will use two load steps to set up the analysis: Load Step 1: Interference Fit -- solve the problem with no additional displacement constraints. The pin is constrained within the pinhole due to its geometry. Stresses are generated due to the general misfit between the target (pinhole) and the contact (pin) surfaces. Load Step 2: Pull-out -- move the pin by 1.7 units out of the block using DOF displacement conditions on coupled nodes. Explicitly invoke Automatic Time Stepping to guarantee solution convergence. Read results for every 10th substep during solution.**

# Introduction of ANSYS - post processing

## ■ Animation

### ■ Utility Menu>PlotCtrls>Animate

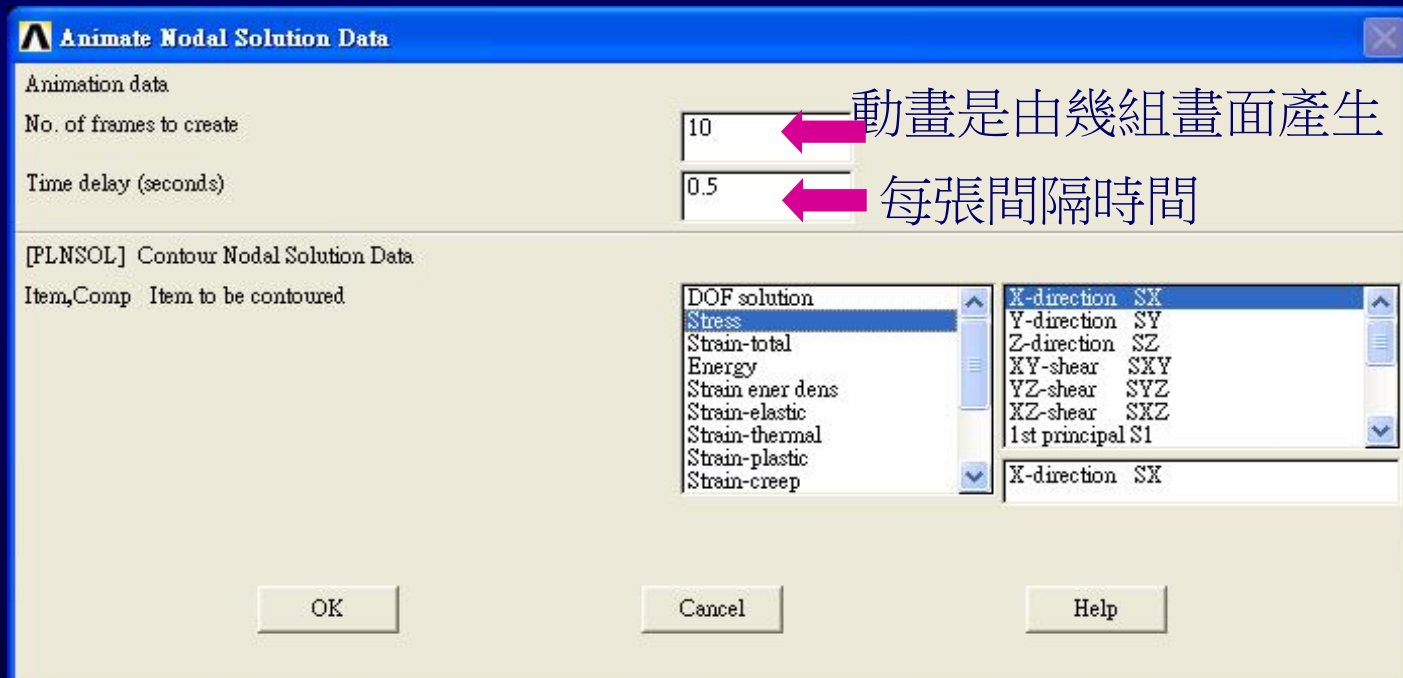

### ■ Utility Menu>PlotCtrls>Animate>Save

### ■ Demo

