

CAD/CAE/CAM and RE/RP/RT (3C/3R)於 顱顏牙科力學之應用研究及醫療器材法規介紹

The Application of CAD/CAE/CAM and RE/RP/RT (3C/3R) in Dental/Craniofacial Biomechanics and Introduction of Medical Device Regulations for Implant

林峻立 教授

國立陽明大學生物醫學工程學系

Chun-Li Lin, Ph.D.

Department of Biomedical Engineering,

National Yang-Ming University, Taiwan

CAEB Lab.Website <http://caebserver.weebly.com/>

Outline

- **3C (CAD\CAE\CAM)**
 - **Computer Aided Design**
 - **Computer Aided Engineering**
 - **Computer Aided Manufacture**
- **Medical Device Regulations for Implant**
- **3R (RE\RP\RT)**
 - **Reverse Engineering**
 - **Rapid Prototyping (3D-printing)**
 - **Rapid Tooling**

醫療器材重要性 (Importance of Medical Device)



全球醫療器材市場概況 (Global Market)

• 全球市場規模

根據BMI 2013研究數據指出, 2012年全球醫療器材市場規模為 3,046億美元, 2016年CAGR = 6.9% , 達到3,983億美元

• 區域市場分析

- 美洲地區 : 45.8%
- 歐洲地區 : 29.5%
- 亞太地區 : 17.8%
- (台灣市場佔亞太的2.74%)

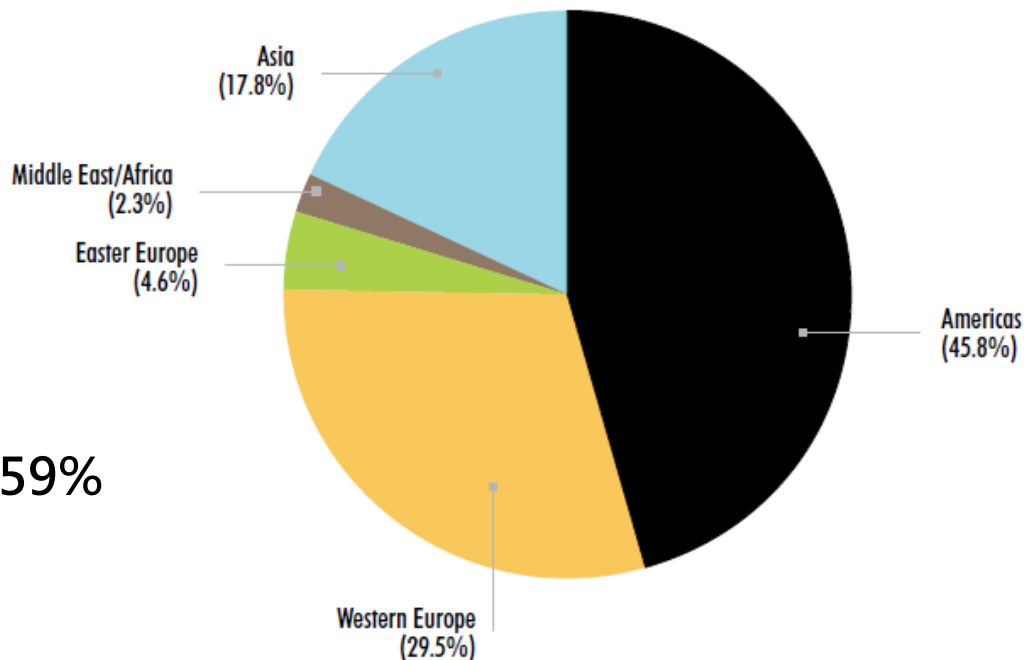

台灣市場佔全球醫材市場0.59%



全球排名第23位

台灣生物科技產業現況-多元化發展

生技產業範疇

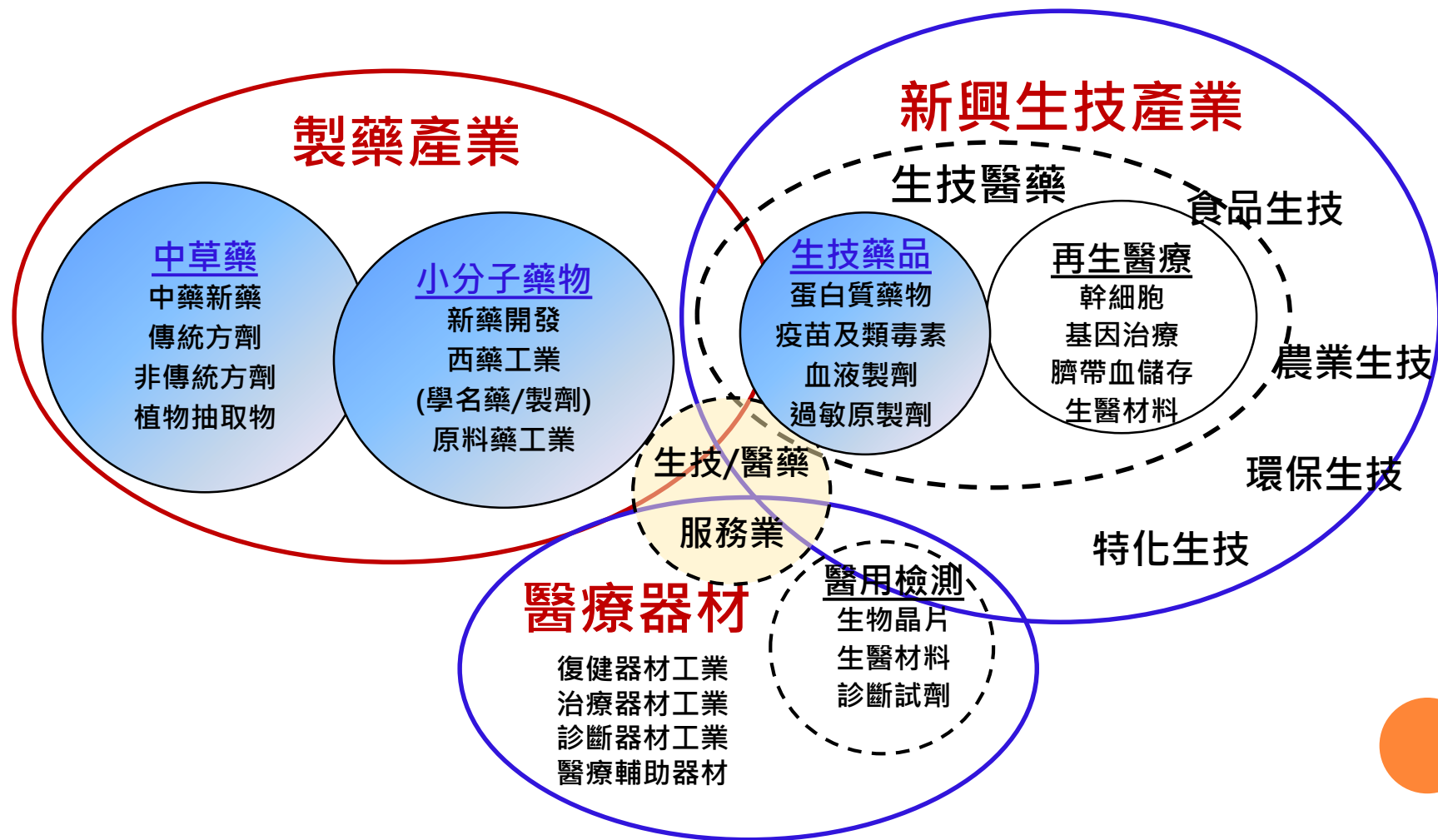

台灣生技醫藥產值

- 醫療器材2007~2011年平均成長率為 7%
- 2006年起我國醫療器材產業已經超越製藥產業，成為我國生技醫藥產業之龍頭

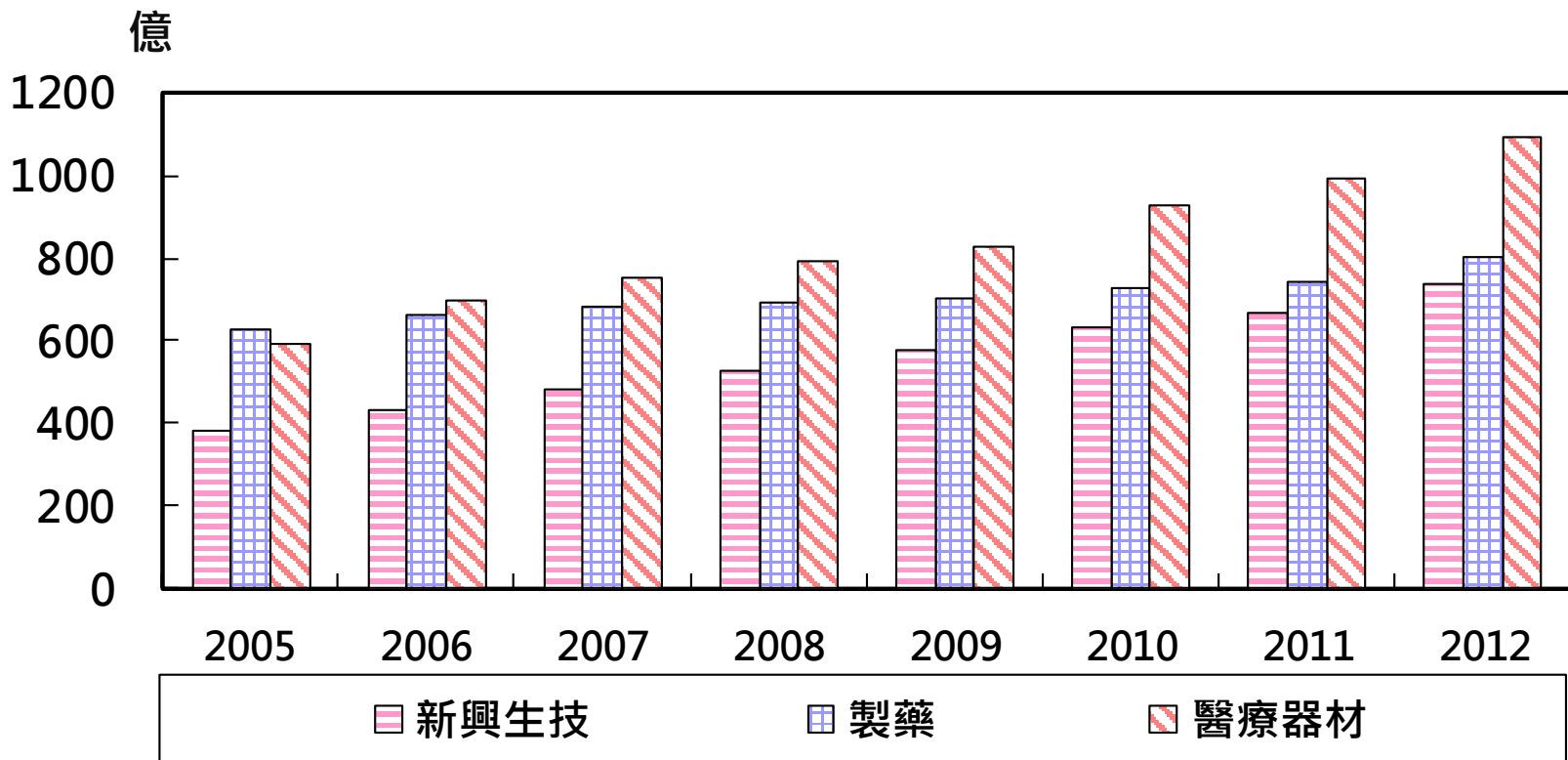

資料來源：經濟部生技與醫藥推動小組 2005年至2013年白皮書產值

全球vs台灣醫療器材市場

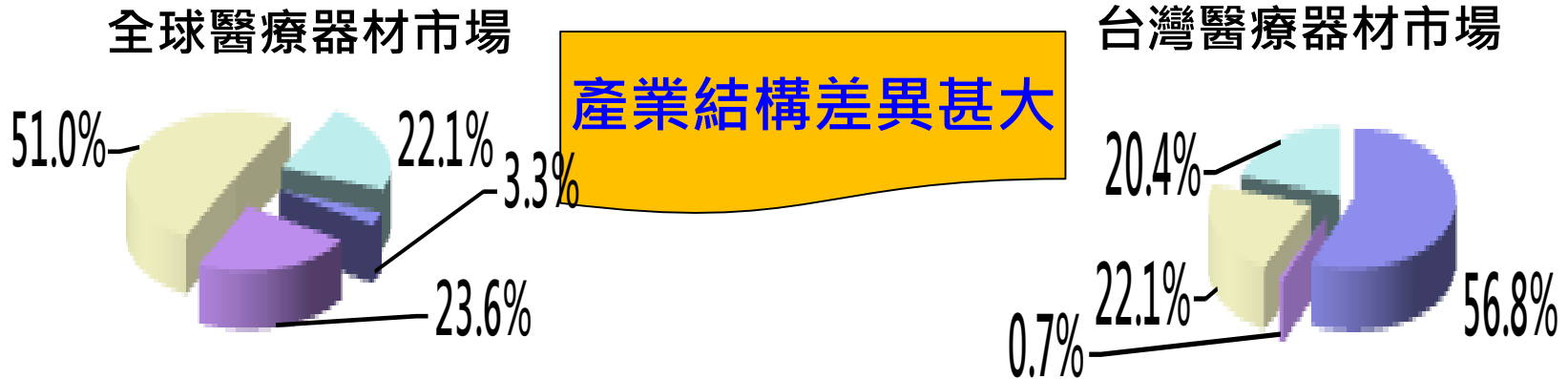

居家用消費型醫材：台灣56.8% vs. 全球 3.3%

醫院用診斷監測設備：台灣0.7% vs. 全球 23.6%

醫院治療用產品：台灣22% vs. 全球 51.0%

- 居家用消費型醫材：輪椅、代步車、血壓計、體溫計、血糖計等。
- 醫院用診斷監測設備：X光儀器設備、心電圖、超音波、MRI、生理監視器等。
- 醫院治療用產品：牙科、眼科與骨科儀器設備、手術器械、骨科與牙科彌補物等。
- 耗材：手套、注射器與導管、急救箱、包紮敷料等。

目前台灣醫材產業，逐漸由居家用醫材，轉換為高階醫材(較高風險)發展，企圖有效提升醫材產值與市場佔有率。

GHTF (Global Harmonization Task Force) 醫療器材分類

- 1992 年由美國、歐盟、日本、加拿大與澳洲五個成員發起成立
- GHTF 全球醫療器材法規調和會

Class	Risk Level	Medical Device Examples
A	Low-Risk	Surgical retractors / tongue depressors
B	Low-moderate Risk	Hypodermic Needles / suction equipment
C	Moderate Risk	Lung ventilator / orthopedic implants
D	High Risk	Heart Valve / Implantable defibrillator

US FDA 分類醫療器材 (Taiwan TFDA)

- **Class I:** simple, low risk devices
 - General control to ensure safety and effectiveness
 - Mostly exempt from Premarket Notification [510(k)]
- **Class II:** more complex, moderate risk devices
 - General control and Special control
 - Require 510(k) → **Substantial Equivalence (as safe and effective as legally marketed device, SE)**
- **Class III:** most complex, highest risk devices
 - General control
 - Premarket Approval (PMA) → **Safety & Effectiveness**



Low risk medical device development

❖ 口腔開合運動復健器設計開發及臨床測試

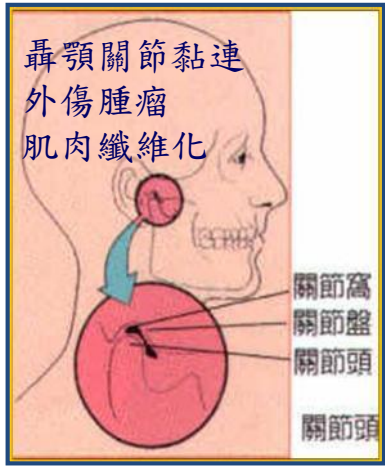

顳顎關節障礙

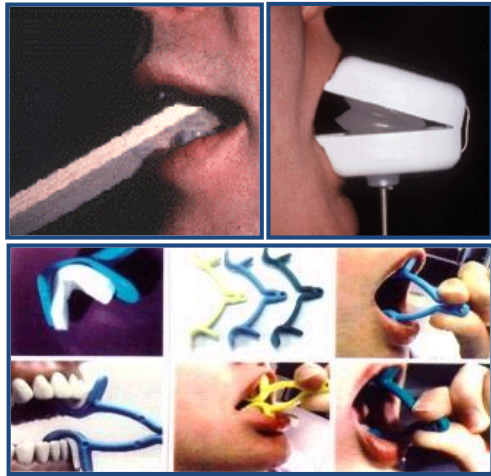

CAD

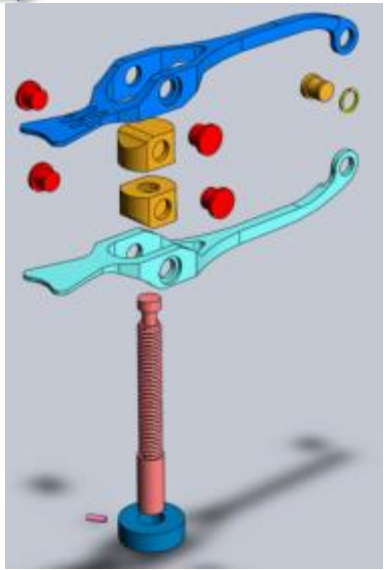
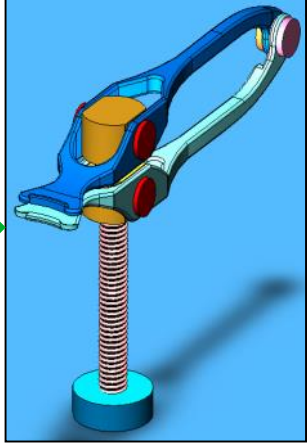

CAM



Clinical Test

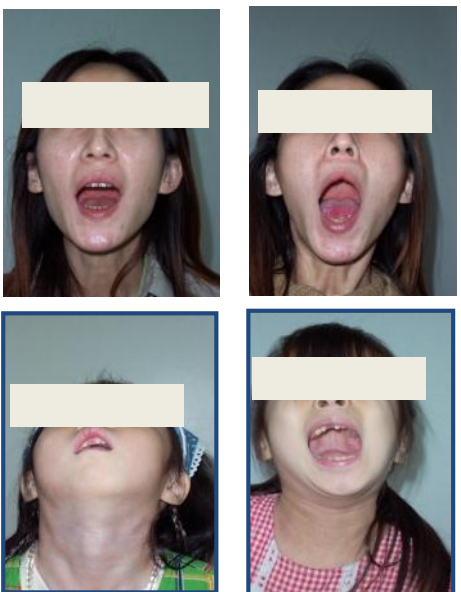

3C/3R (CAD/CAM/CAE, RE/RP/RT)

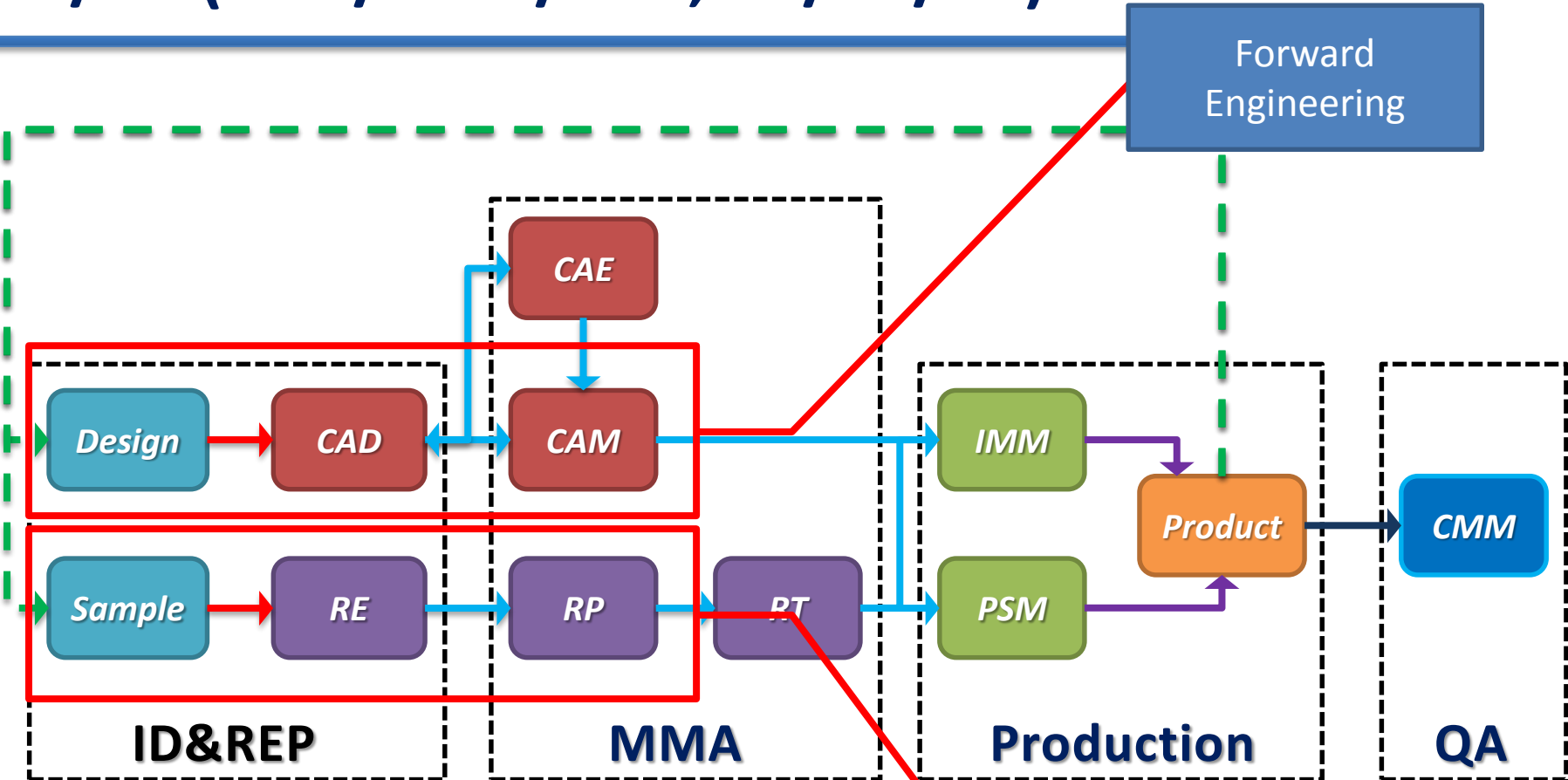

ID : Industrial design

IMM : Injection mould machine

QA : Quality assurance

MMA : Mold manufacturing & analysis

PSM : Pressing/shearing machine

Reverse Engineering

CAD/CAM clinical application

❖ 下頷角整形手術輔助器具設計

國字臉矯正手術

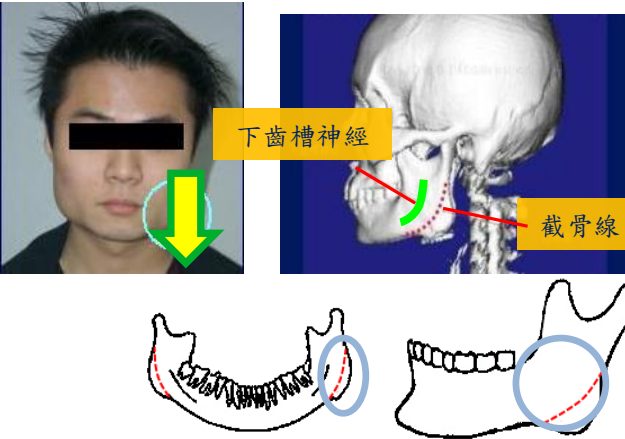

下頷角量測輔助器械



皮膚保護套

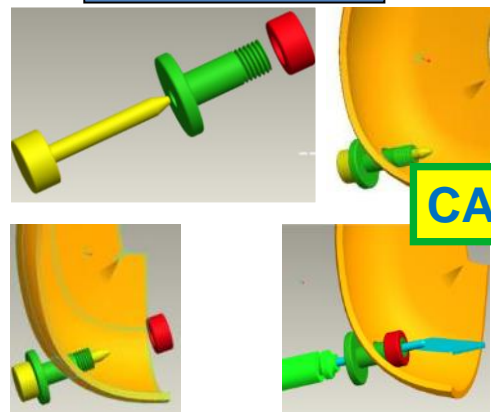

CAM

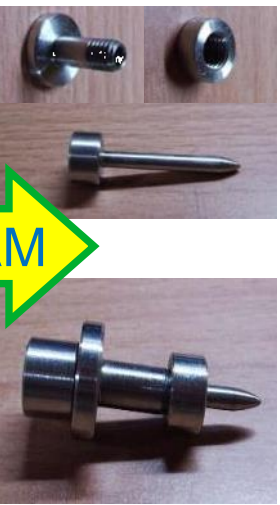

Clinical Test

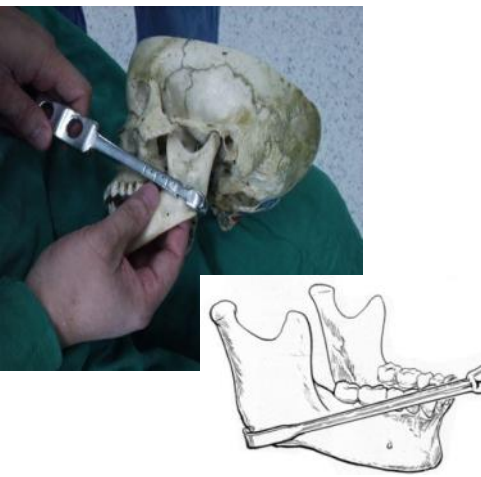

術前

術後



3C(CAD/CAM/CAE)

❖ 電腦輔助設計 (Computer Aided Design, CAD)

→ 運用工程圖學原理-應用幾何、正投影、剖視圖、尺度標註、公差、表面符號

→ 透過手繪(早期)或電腦軟體製圖 (AutoCAD)

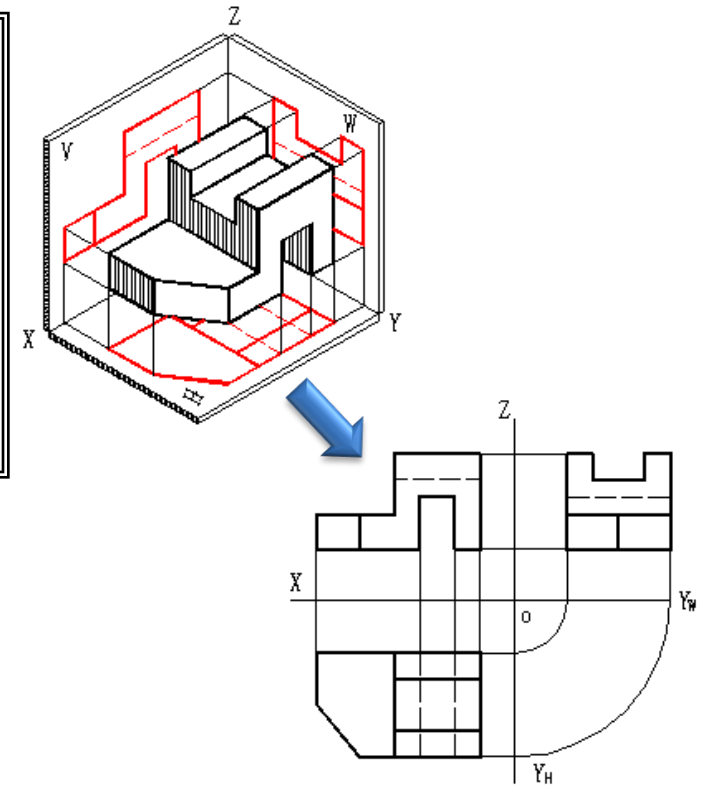
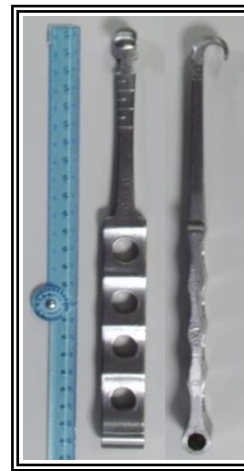
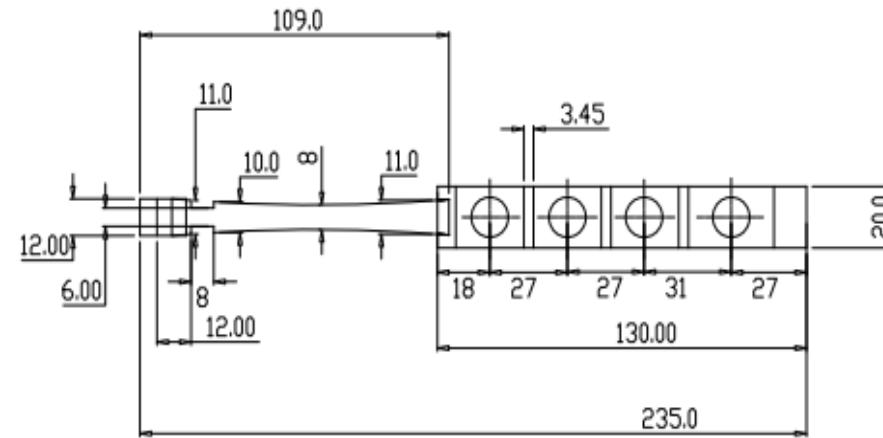



2D三視工程圖

3C (CAD/CAM/CAE)

❖ 電腦輔助設計 (Computer Aided Design, CAD)

→ 運用 **電腦參數化軟體** 進行實體設計 (Pro/Engineering、Solidworks)

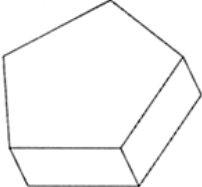
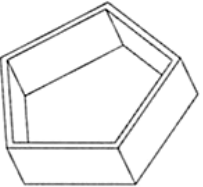
→ 參數化繪圖原理採 “特徵” (Feature) 為基礎之特性，利用一般自然的機械物件之觀念，如 引伸、旋轉、掃描、導圓角、薄殼、鑽孔 等，以最自然的思考方式從事設計工作。擺脫了傳統以點、線、面為主的系統架構，目前的3D CAD系統皆採用 “特徵” 的原則。

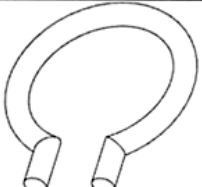
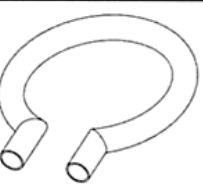
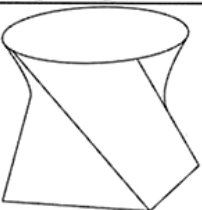
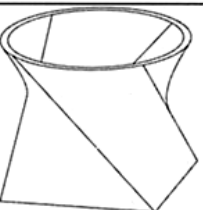
■長肉 (加材料) -Protrusion		
	實體 (Solid)	薄長薄肉 (Thin)
引伸 (Extrude)		
旋轉 (Revolve)		
掃描 (Sweep)		
混合 (Blend)		

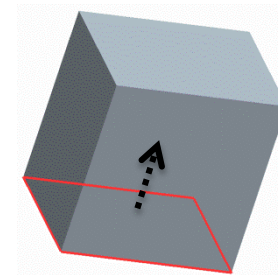

長出

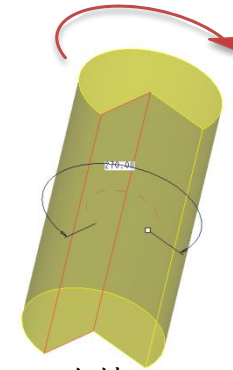

旋轉

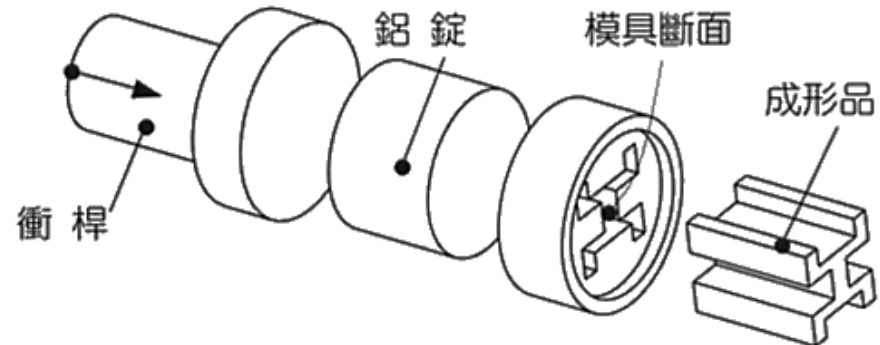

3C (CAD/CAM/CAE)

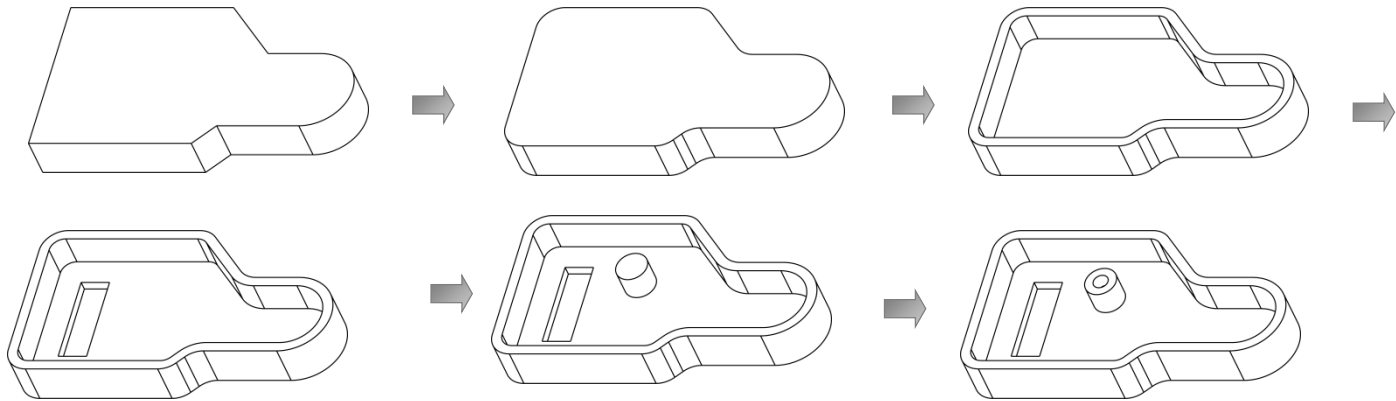

1個「零件」= 特徵1 + 特徵2 + 特徵3 + ... + 特徵N

1個「組立件」= 零件1 + 零件2 + 零件3 + ... + 零件N

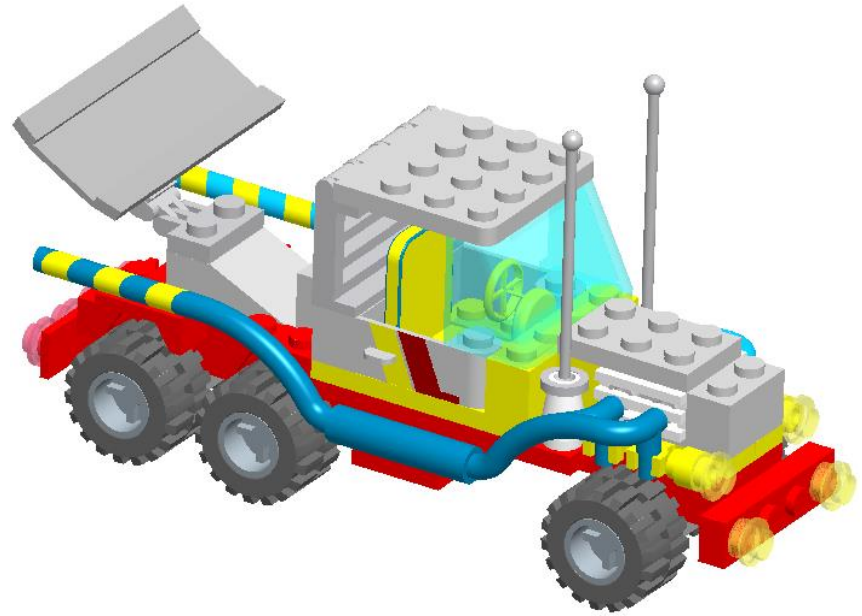
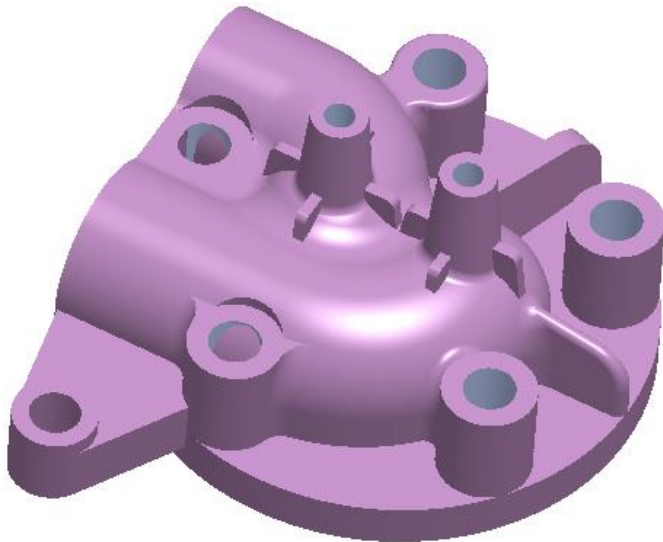

3C (CAD/CAM/CAE)

❖ 電腦輔助設計 (Computer Aided Design, CAD)

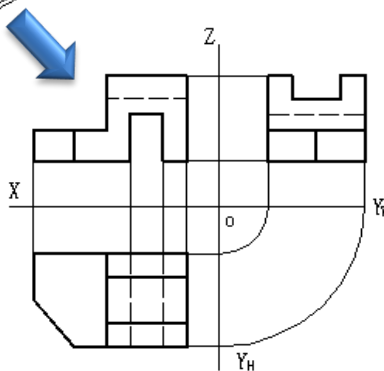
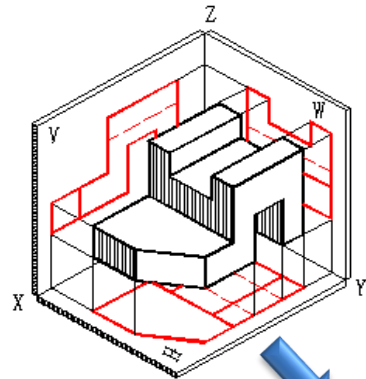
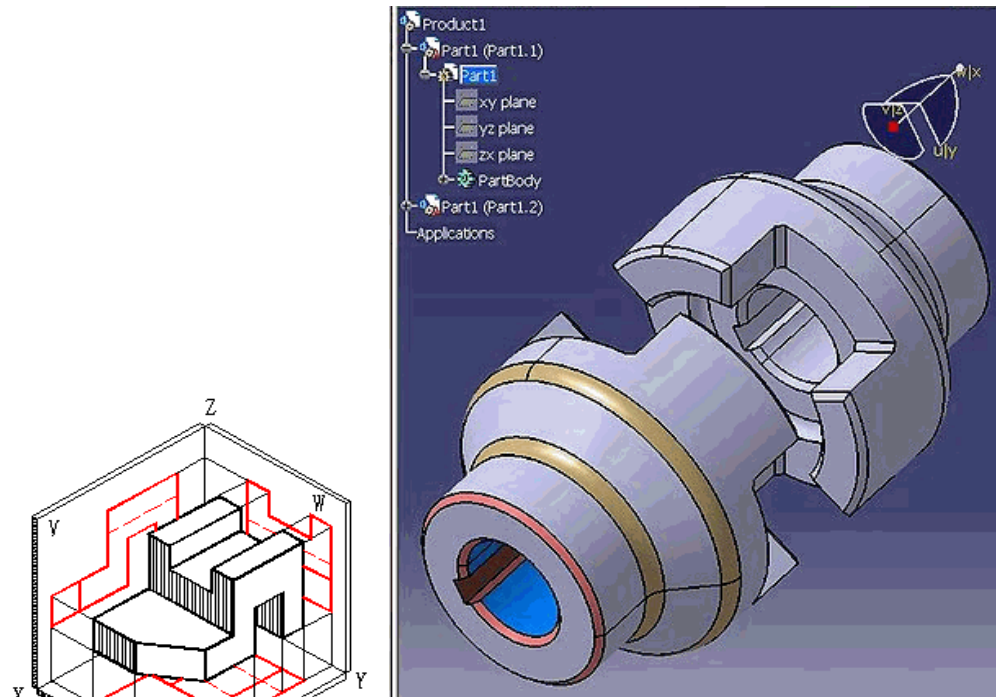

實體/模型

三視工程圖

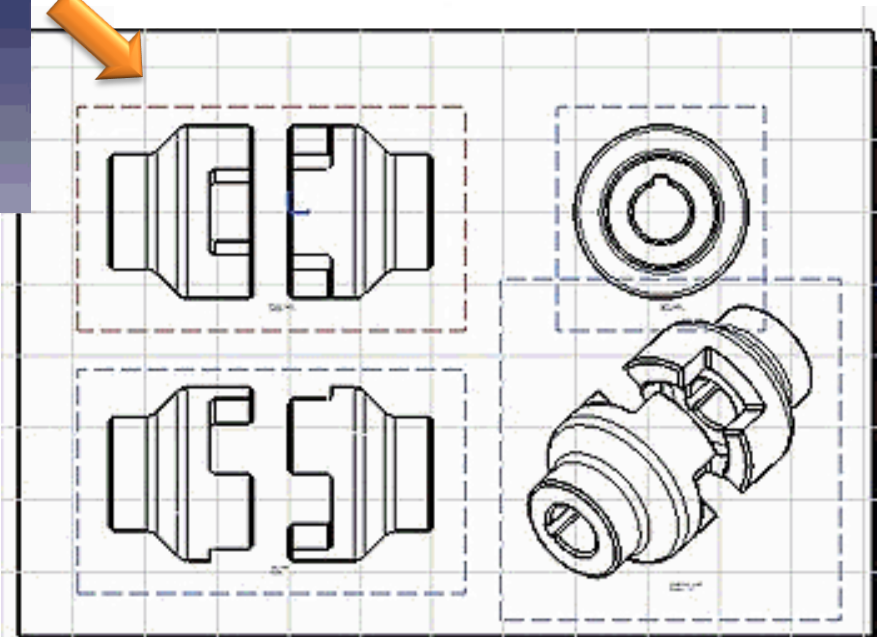
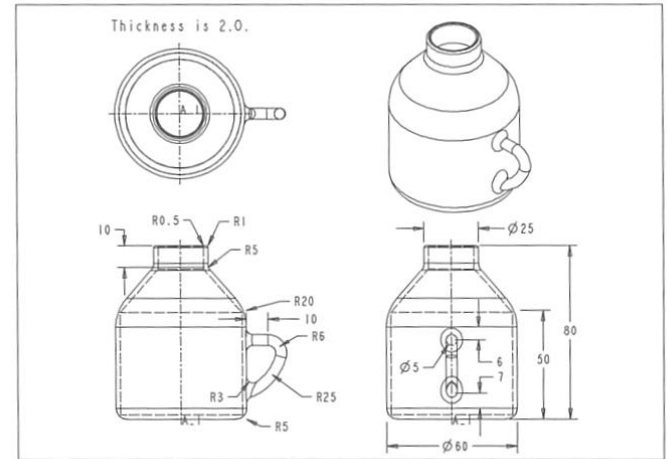

3C (CAD/CAM/CAE)

- ❖ 電腦輔助設計 (Computer Aided Design, CAD)
- ❖ 機構設計原理

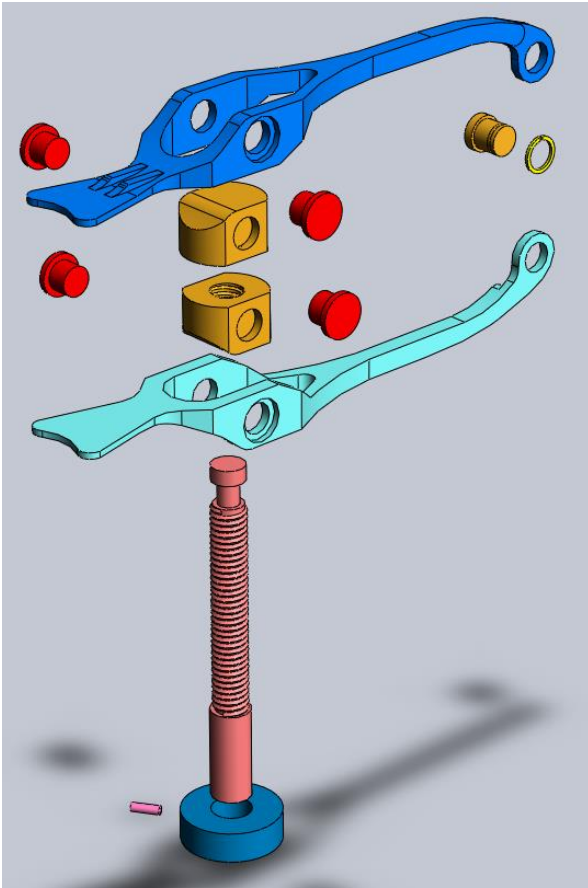

3D 模型繪圖

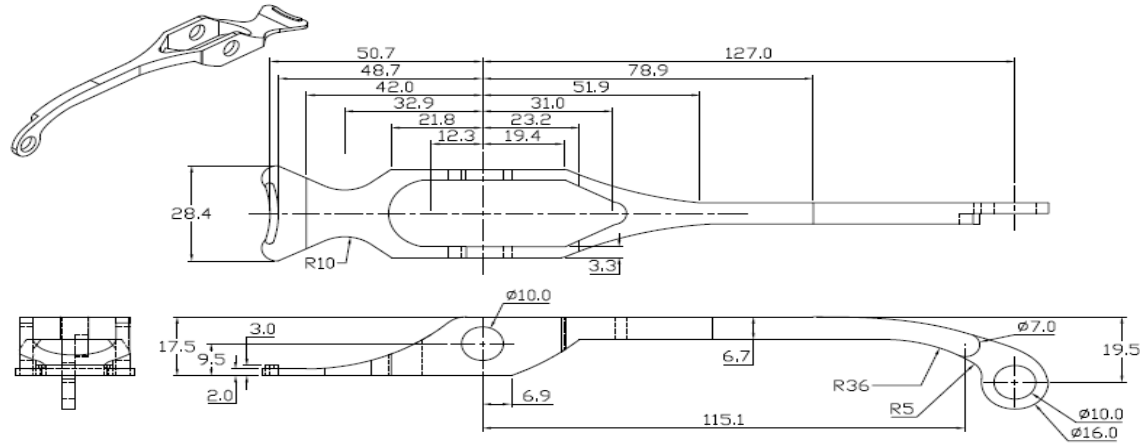

2D三視工程圖



衛署衛署醫器製壹字第003944
 世亨科技股份有限公司 (02)-29



行政院衛生署第一等級醫療器材許可證

醫療器材製壹字第 003944 號

中文名稱：「世亨」一般手術用手術器具組(非滅菌)

英文名稱："SHIH HENG" Manual Surgical Instrument for General Use(Non-Sterile)

類別：第1類：一般及醫用外科手術器具

廠商名稱：世亨科技股份有限公司

規格：空白

製造廠名稱：世亨科技股份有限公司

製造廠地址：新北市新莊區福營路145巷25號

效能：照醫療器材管理辦法「一般手術用手術器具組(400)」第一等級組別規定。
 處方：空白。

前項醫療器材經本署審核與醫事法之規定相符應發給許可證以資證明

行政院衛生署署長



邱文達

發證日期 中華民國 年 月 日
 有效日期 中華民國 年 月 日

核准日期				
核准地點				
核准人員				
核准日期				

CAD/CAM clinical application

❖ 仰躺式肘關節手術輔助器械之設計與開發手肘



雛形
機構
設計

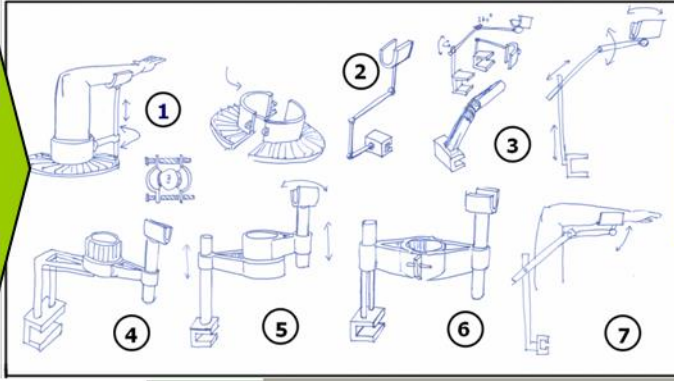

可行
方案
整合

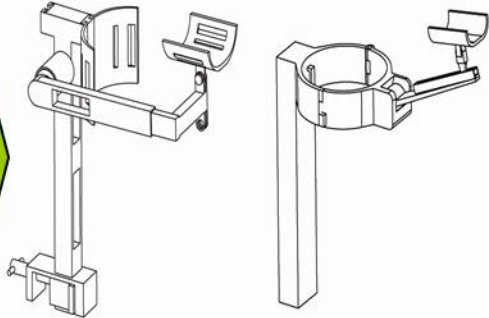

CAD
及
動畫
模擬

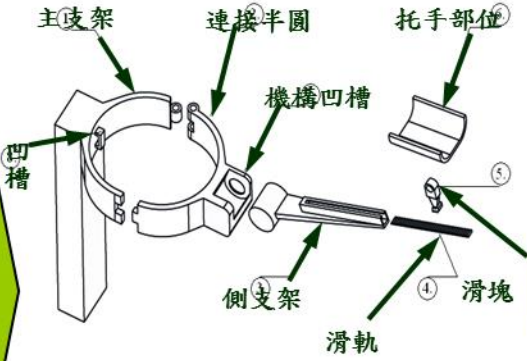

機構
模擬

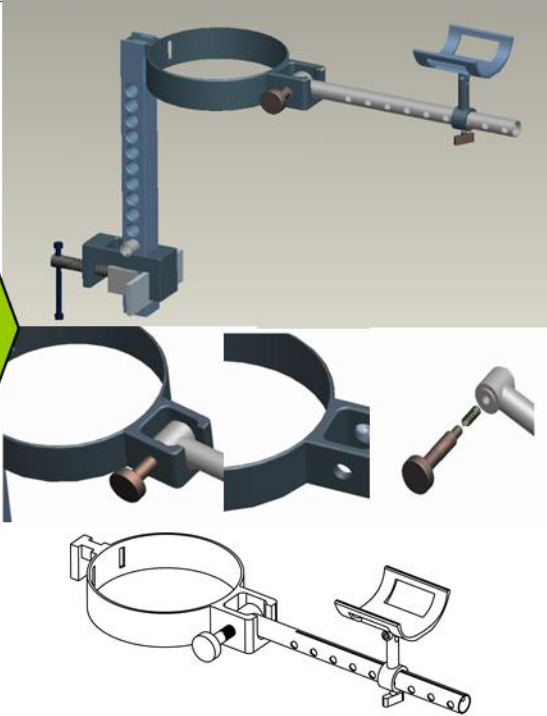

CAM
及
臨床
測試

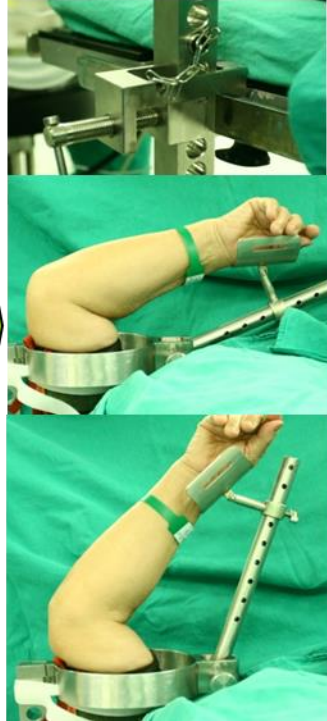

3C (CAD/CAM/CAE)

❖ 電腦輔助製造 CAM (Computer Aided Design)

❖ CNC車銑床、複合切削機(3, 4, 5, 6軸)、精度

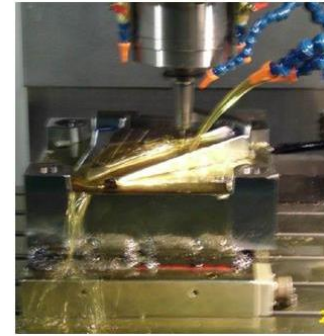
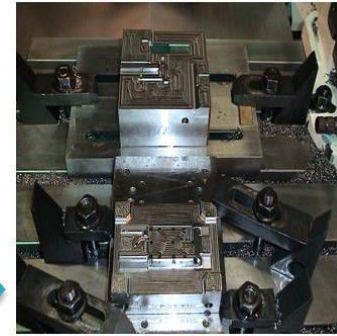
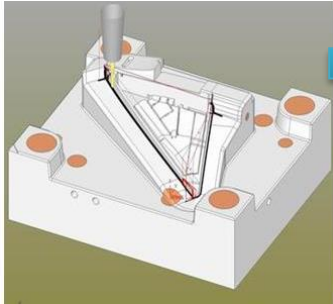

電腦製造路徑規劃

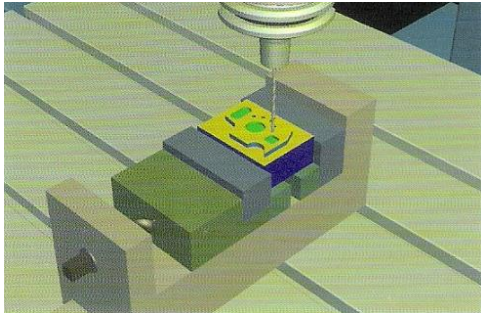

工具機



3C (CAD/CAM/CAE)

❖ 電腦輔助製造 CAM

❖ CEREC (CAD/CAM)

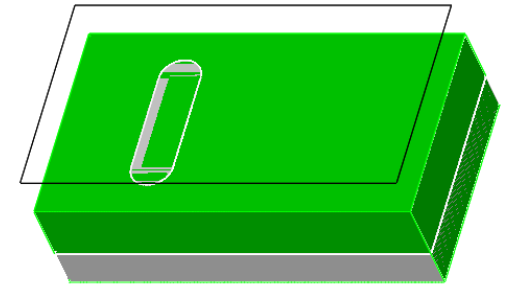

Dental Biomechanics



Orthodontic mini screw

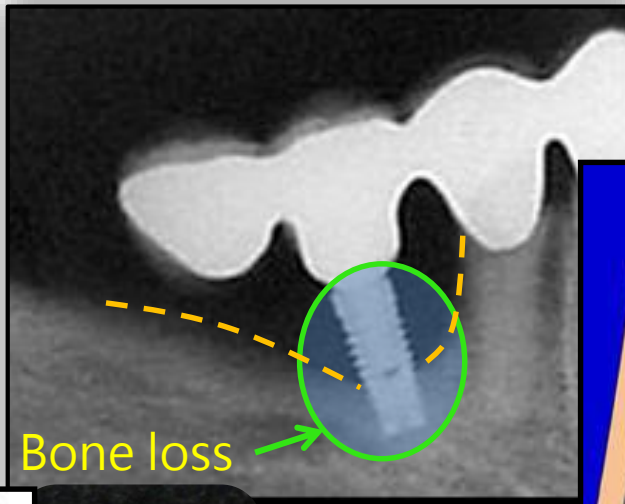

Bone loss

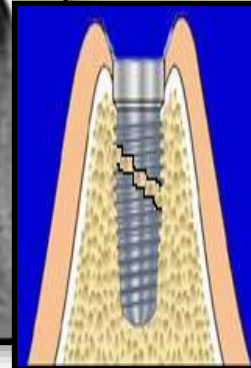

Dental implant

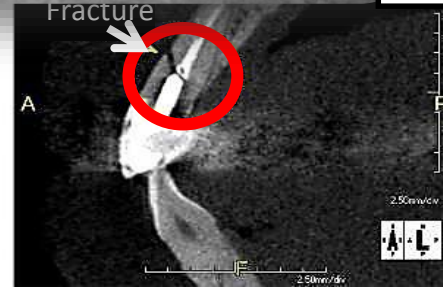
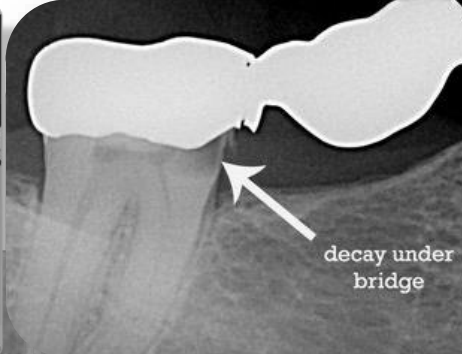
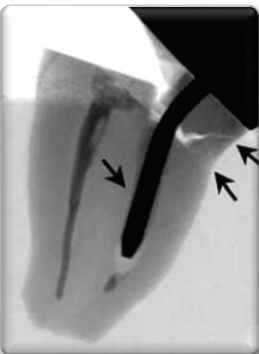

OD & Prosthetic

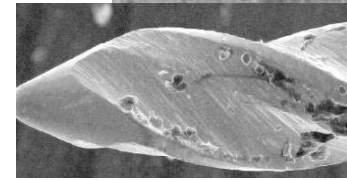
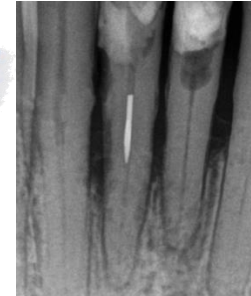
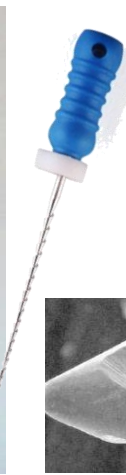
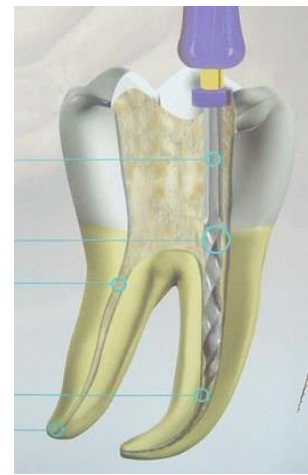

Endodontic

Moderate/High Risk Medical Devices

★安全有效★



工業用螺絲

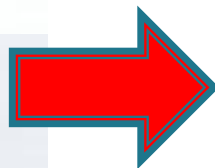

人工牙根

NT0.X→NTX0000

3C/3R (CAD/CAM/CAE, RE/RP/RT)

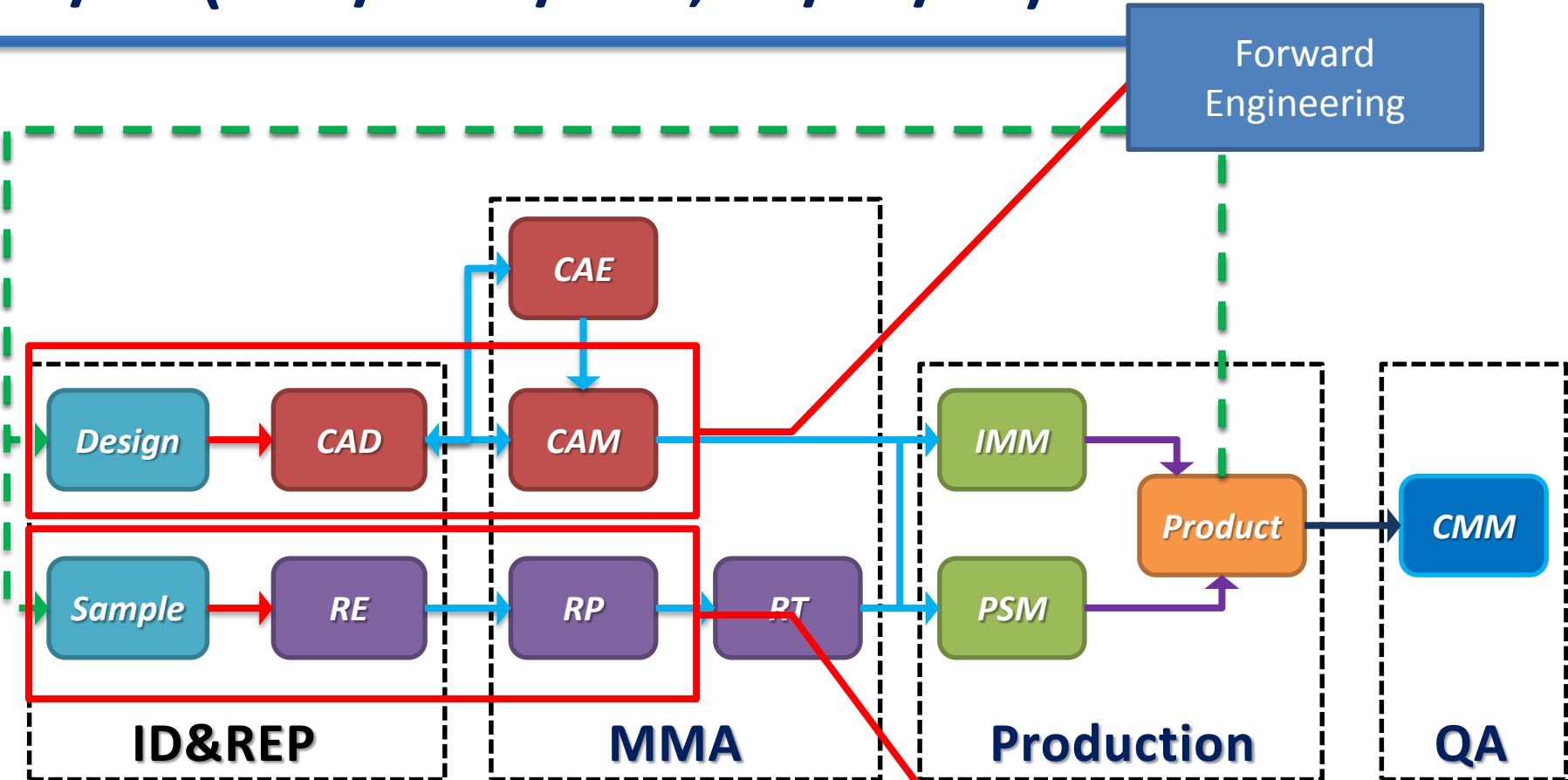

ID : Industrial design

IMM : Injection mould machine

QA : Quality assurance

MMA : Mold manufacturing & analysis

PSM : Pressing/shearing machine

Reverse Engineering

Computer aided engineering (CAE)

- Biological and engineering aspects are suitable but difficult to evaluate by experimental techniques
 - limited information
 - stress, strain, energy, etc.*
 - variation within samples
 - size, age, biochemical, morphologic, etc.*
- Relevant biomechanical rationales still unclear

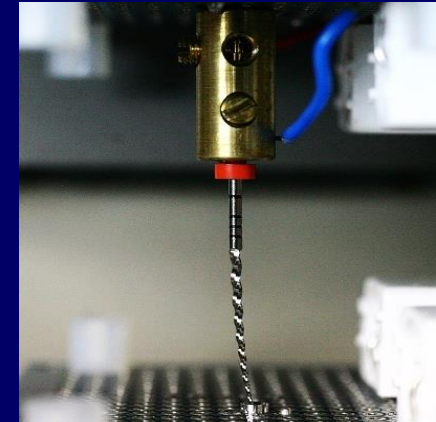
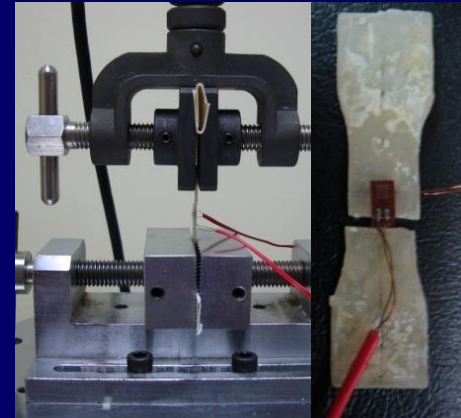
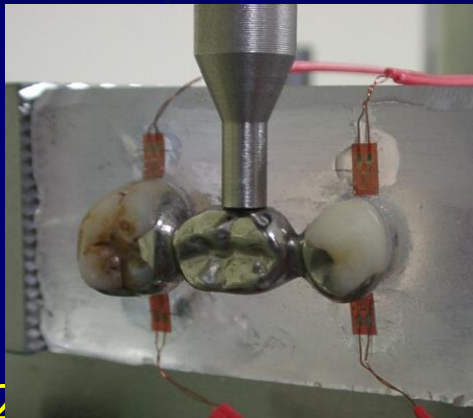
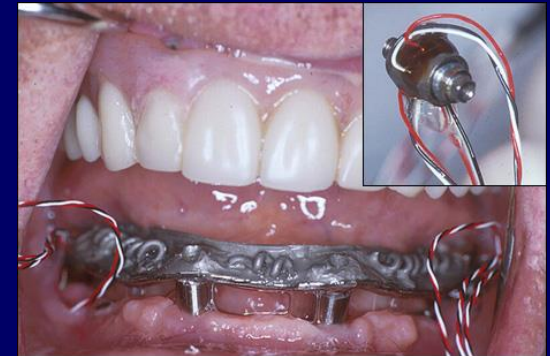

Computer Aided Engineering (CAE)

❖ 電腦輔助工程 (Computer Aided Engineering, CAE)

傳統工程分析

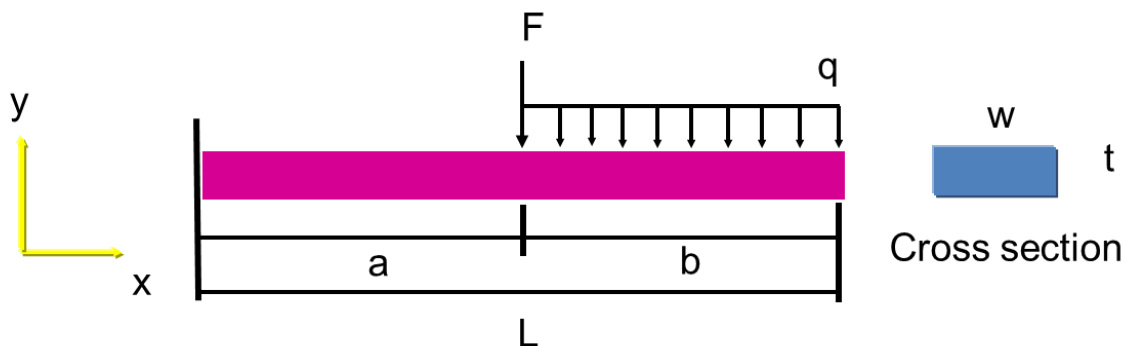
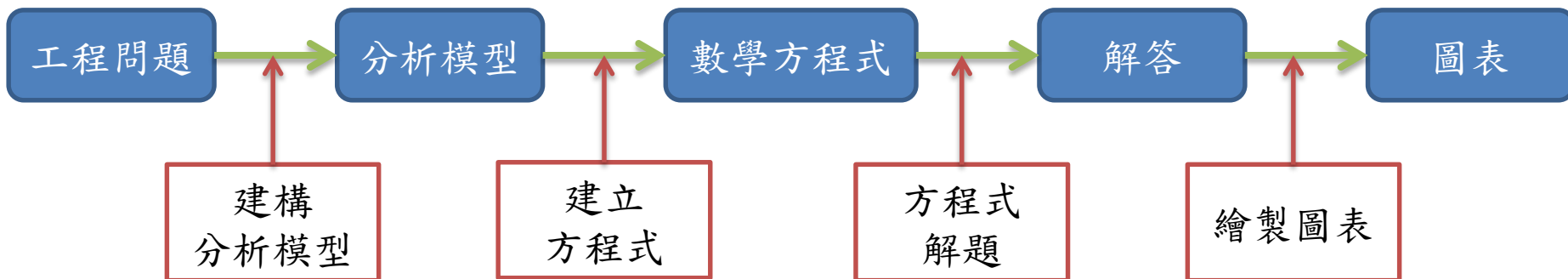

$$y = Fa^3(3L-a)/6EI + q(3L^4 - 4a^3L + a^4)/24EI$$

Analytical analysis



Experimental approach

Computer aided engineering (CAE)

■ Fundamental concepts in FEM

- 實際的物理問題很難利用單一的微分方程式描述，更無法順利求其解析解(analytical solution)
- 有限元素法的精神是將複雜的幾何外型的結構物體切割成許多簡單的幾何形狀稱之為元素(element)
- 元素與元素間以“節點”(node)相連
- 由於元素是簡單的幾何形狀，可順利寫出元素的力平衡方程式並求得節點上之變位、應變及應力等
- 藉由內插法求得元素內任意點的變位、應變及應力等

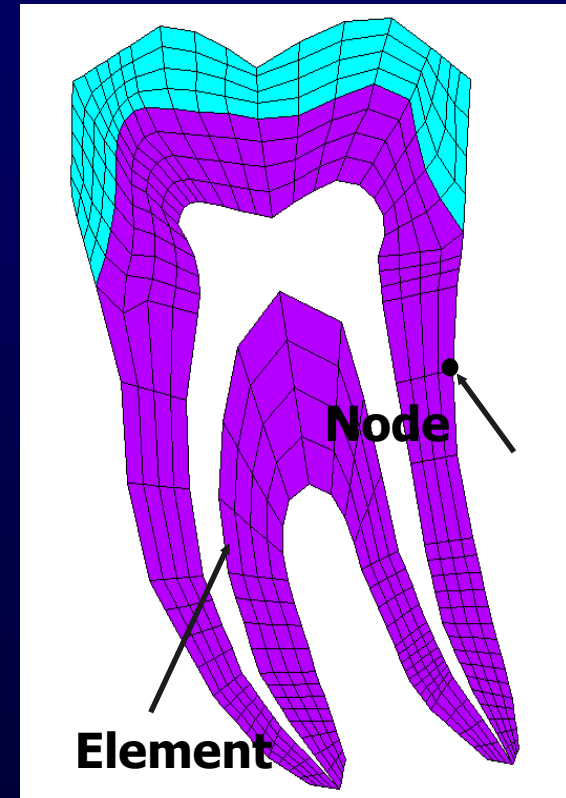

Computer Aided Engineering (CAE)

■ Pre-processing

- Geometry
- Mesh (Element type)
- Materials
- Boundary and loading conditions

■ Solution

■ Post-processing

- Present the results by graphs...

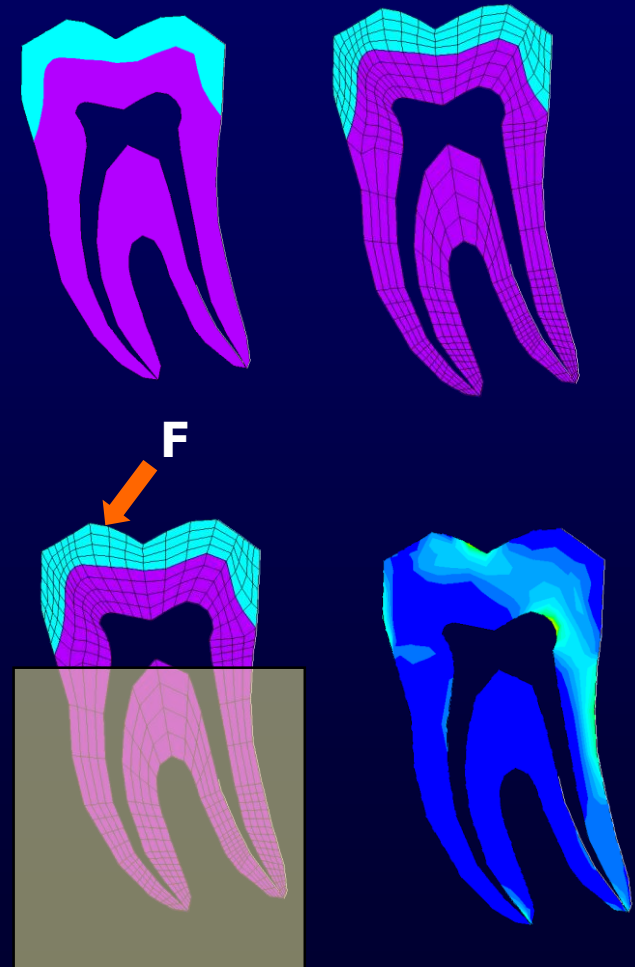

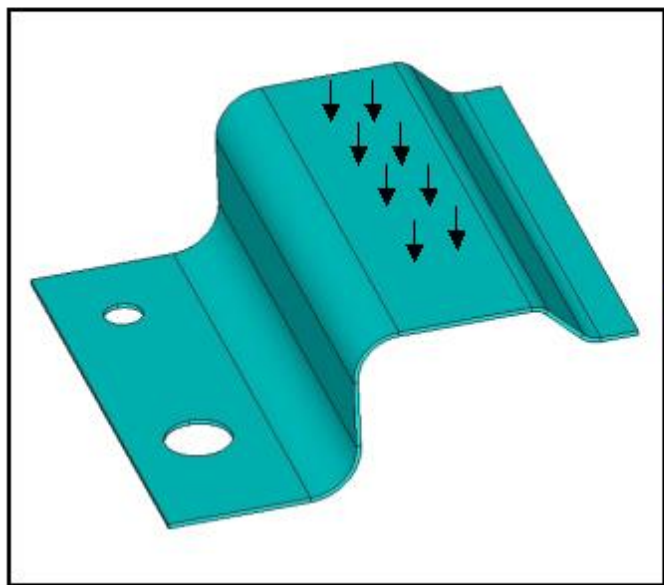

(a) 實際工程問題

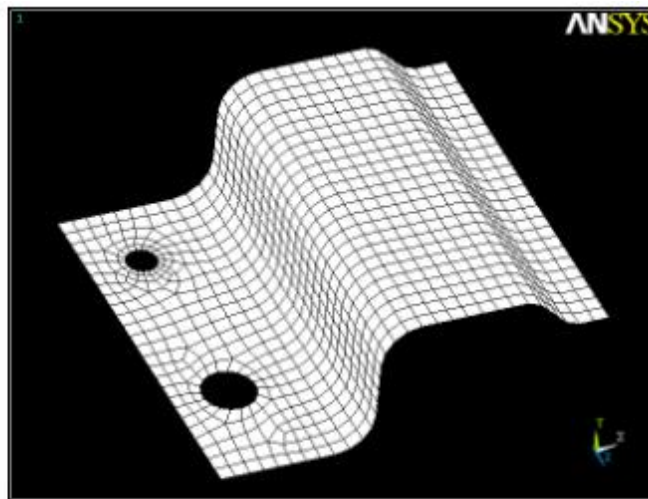

(b) 元素網格

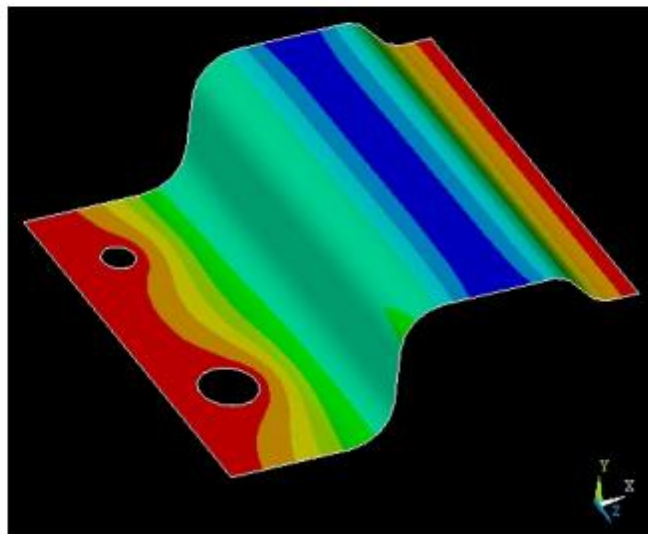

(c) 模擬之變形

CAE general applications

❖ 電腦輔助工程 (Computer Aided Engineering, CAE)

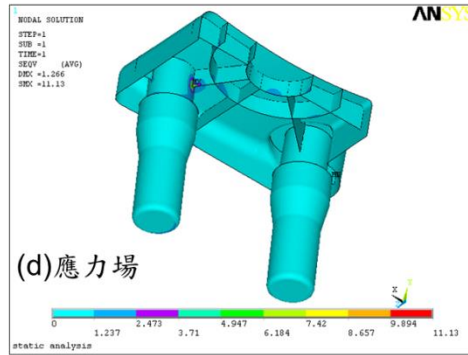
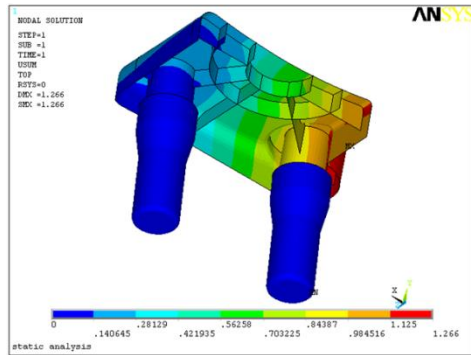
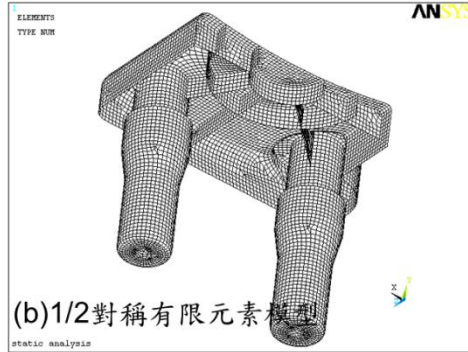
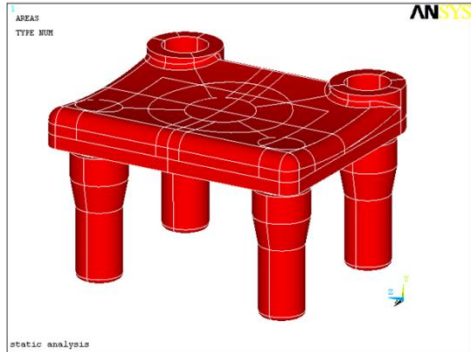

塑膠椅之力學分析

散熱風扇之模態分析

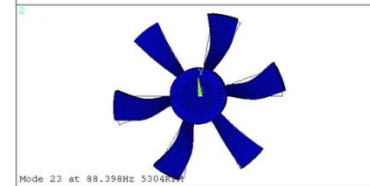
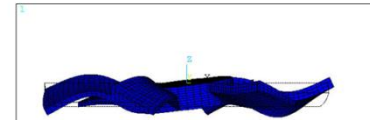
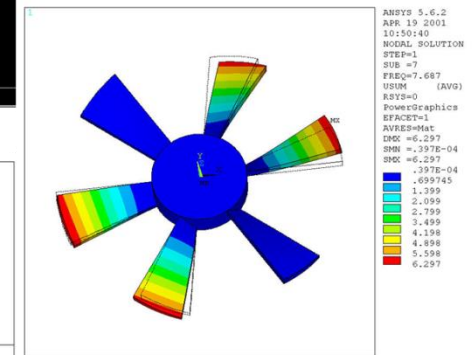
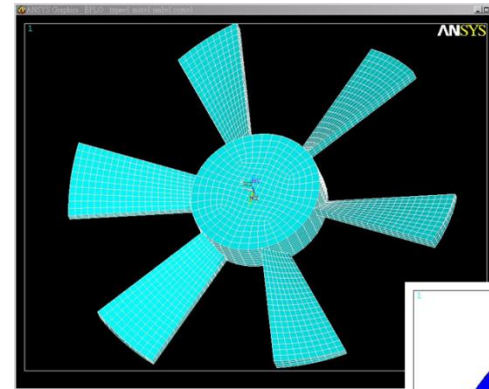

Computer aided engineering (CAE)

- **Computer Aided Engineering**
 - CAE (Finite Element Method)
- **Finite Element Method (FEM)**
 - FEM is suitable theoretically for any structure
 - ⤵ irregular geometry
 - ⤵ inhomogeneity, anisotropy material properties
 - ⤵ complex loading
 - Powerful analytical tool in biomechanics

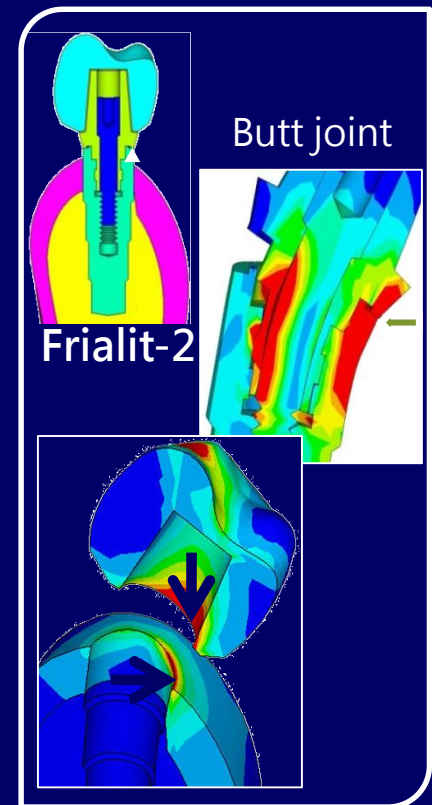
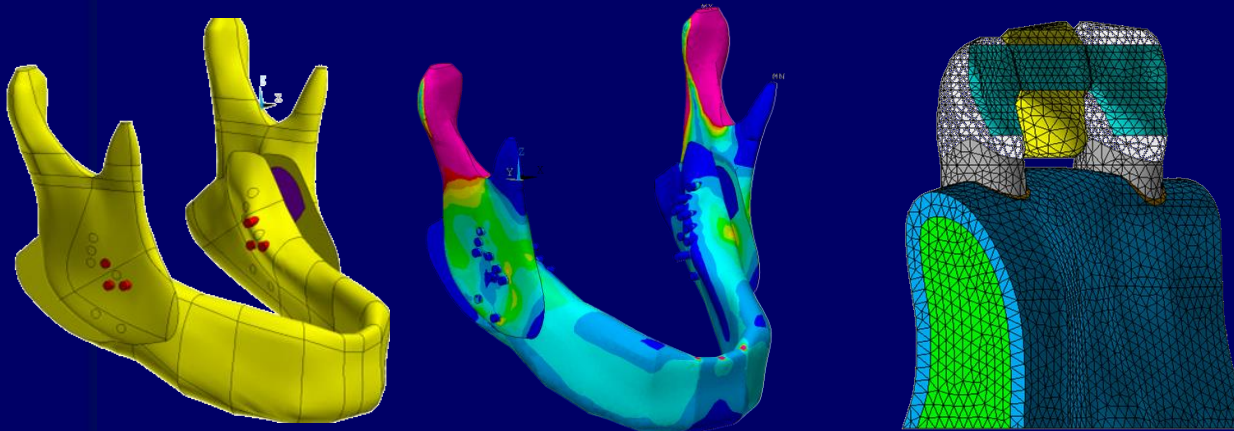

3D modeling for biological structure

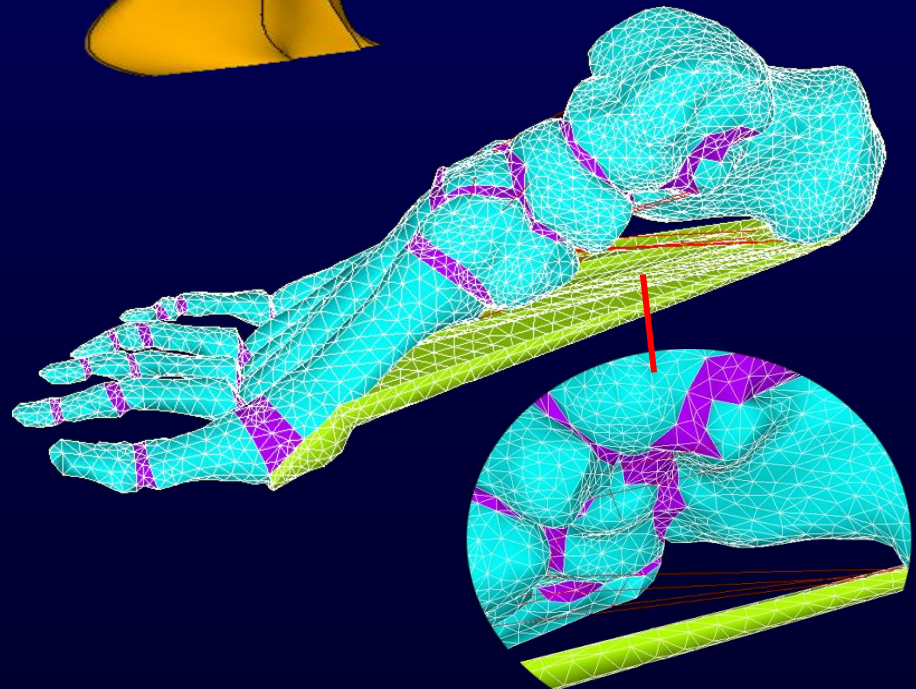
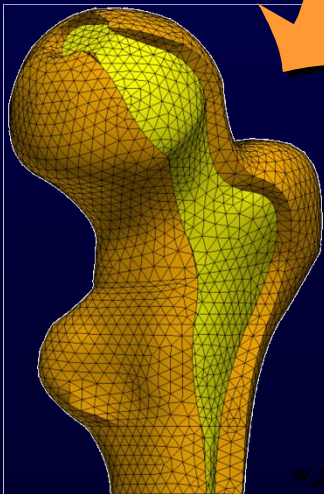
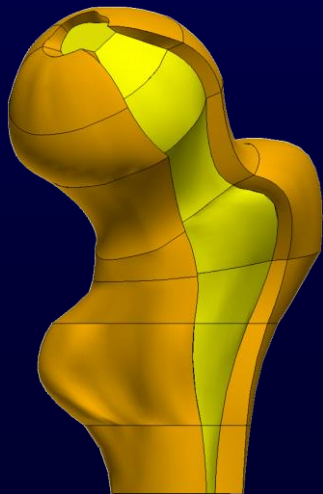
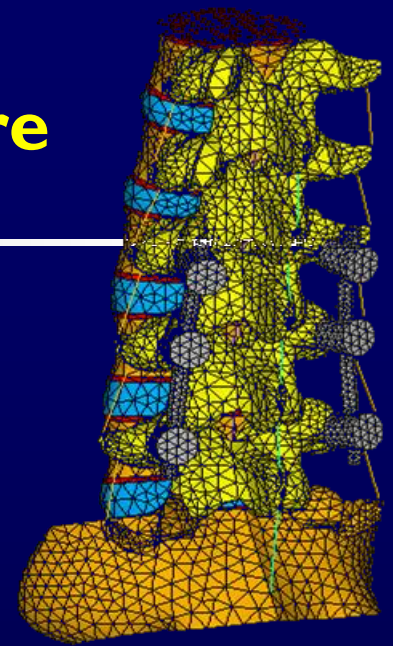
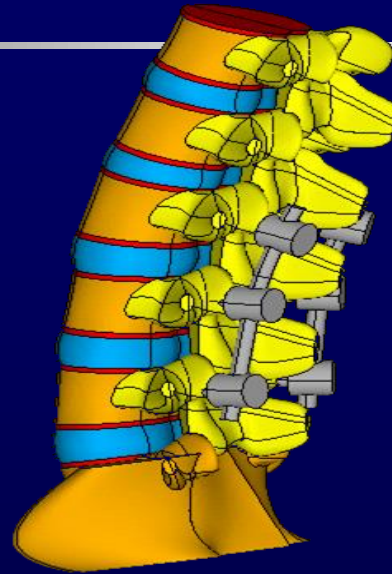
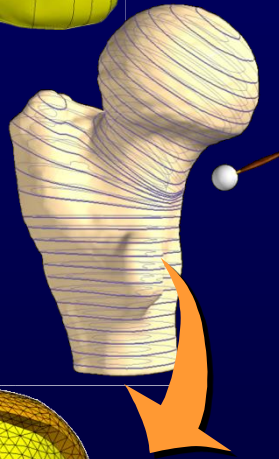
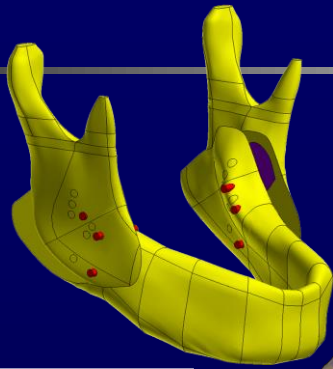

3C

Forward Engineering

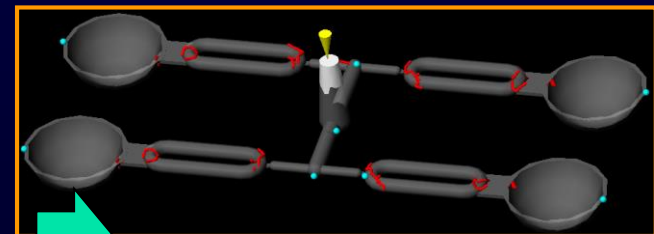
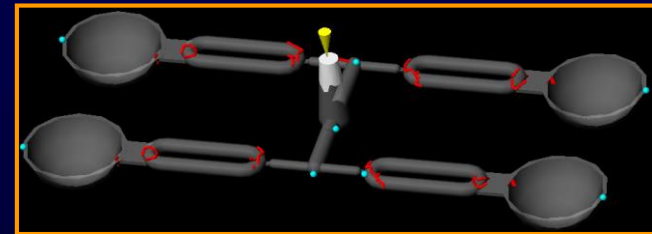
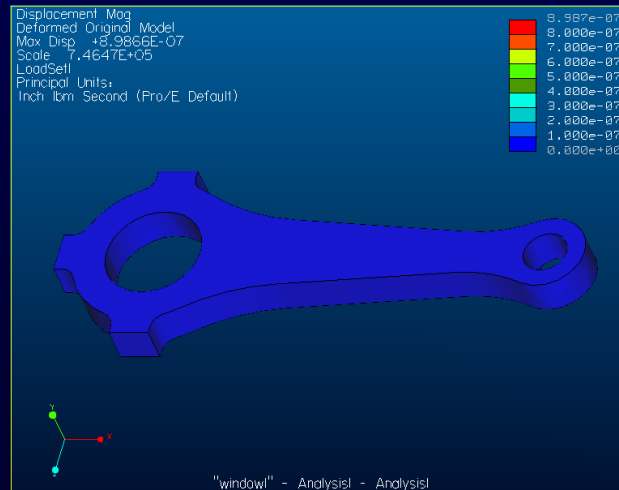
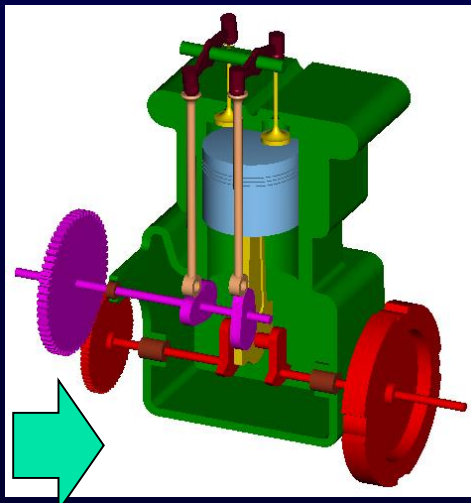
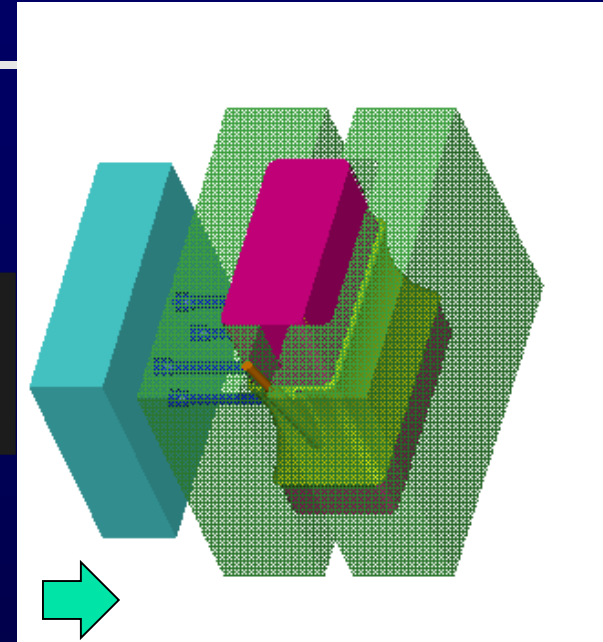

CAE key factors

❖ 電腦輔助分析 (Computer Aided Engineering, CAE)

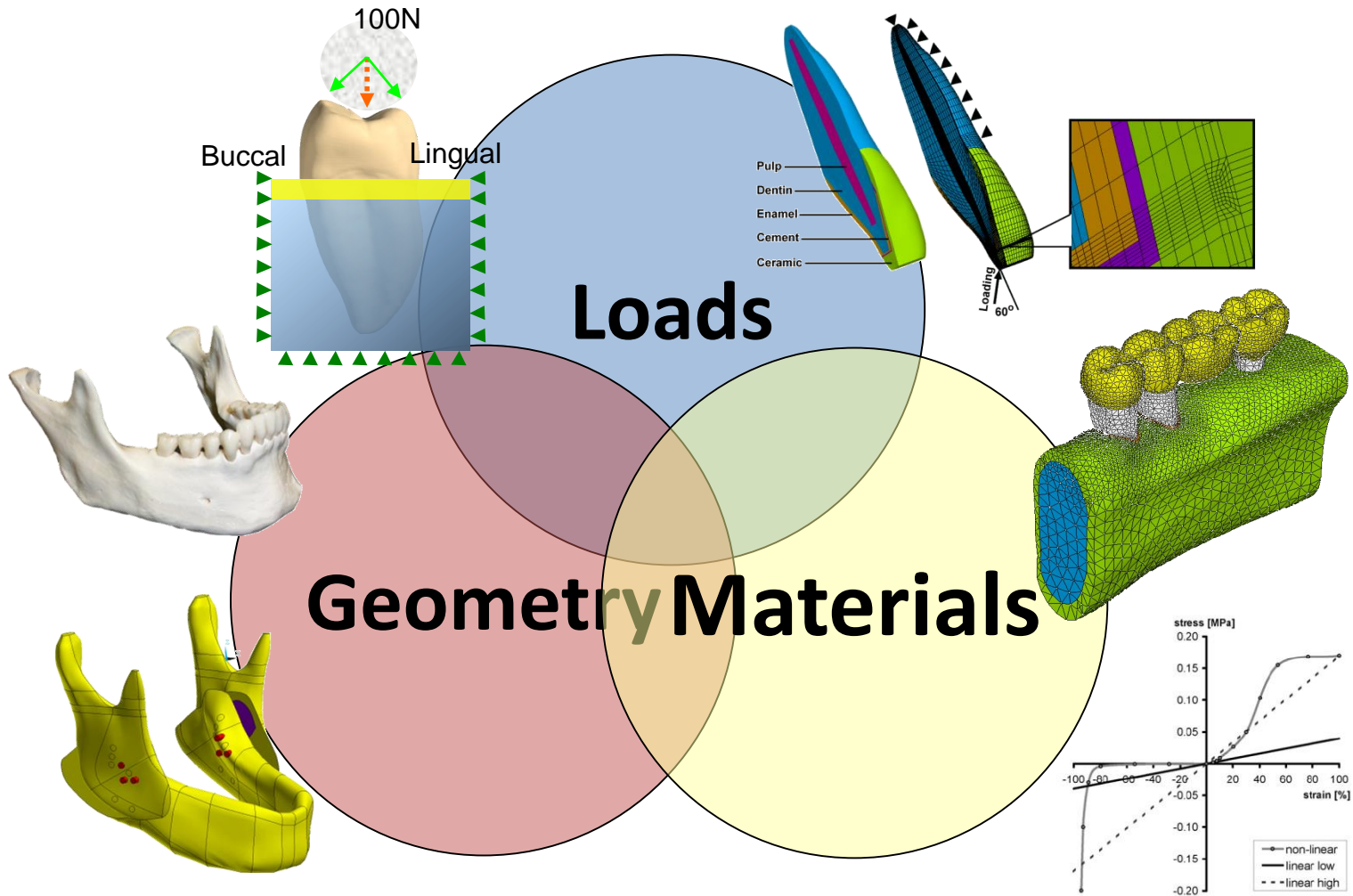

3D modeling for biological structure

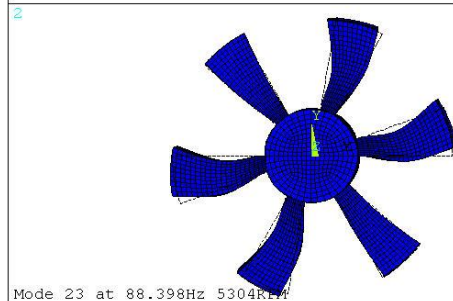
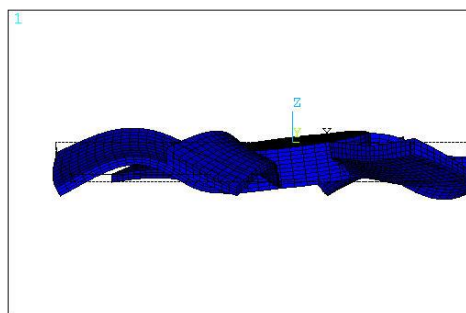
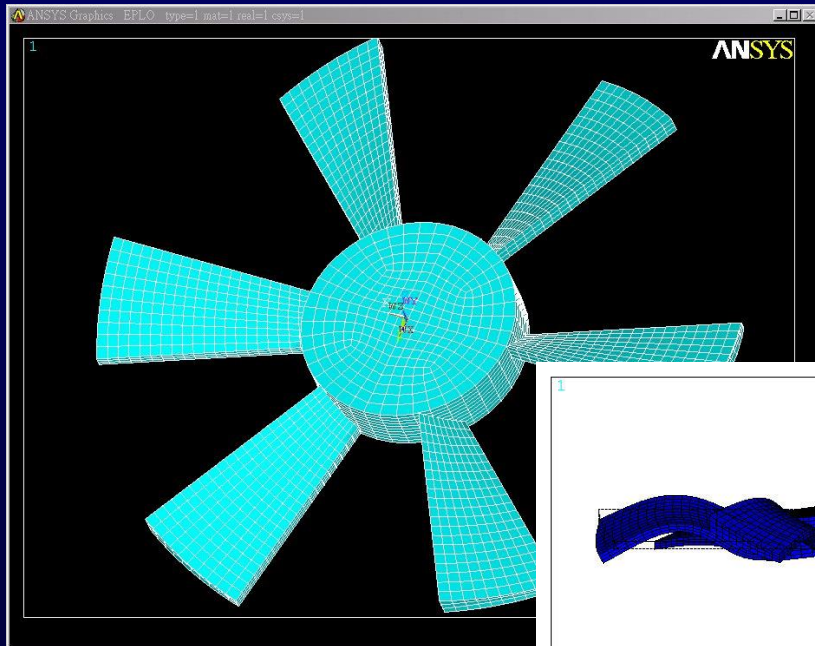

Mode 23 at 88.398Hz 5304REV

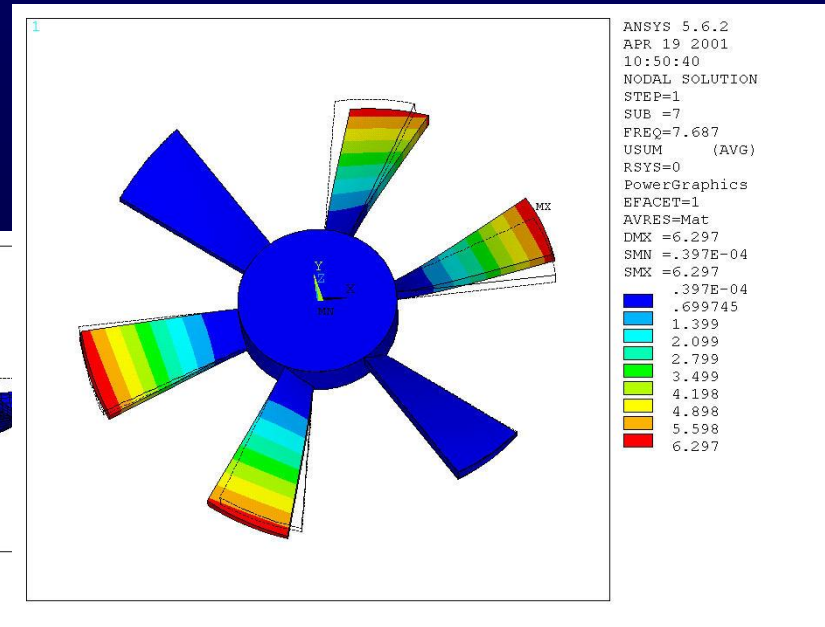

DSCA=.983199
ZV =1
DIST=65.522
XF =.766196
YF =-.613508
ZF =-5.376
Z-BUFFER

3D modeling for biological structure

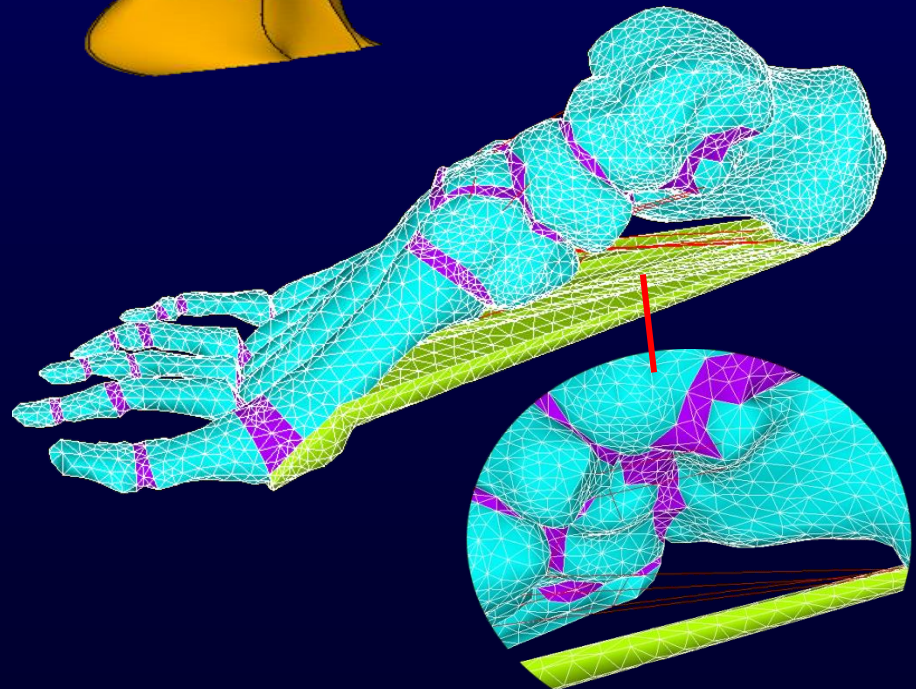
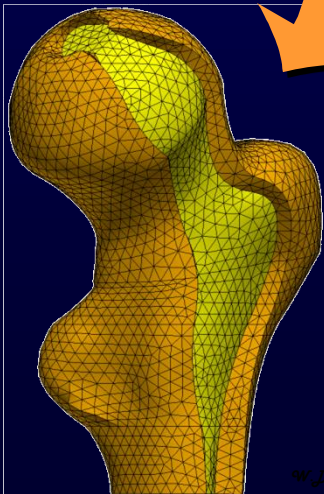
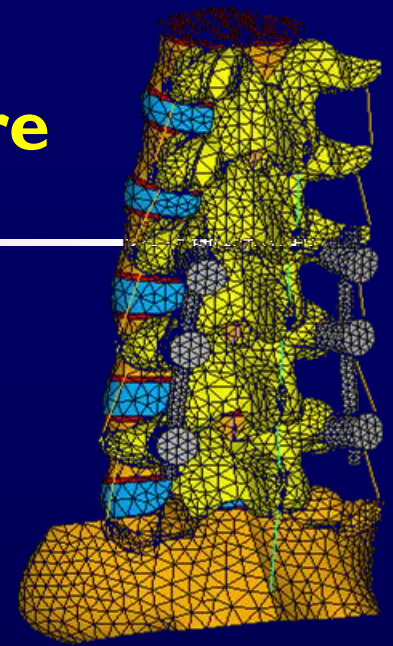
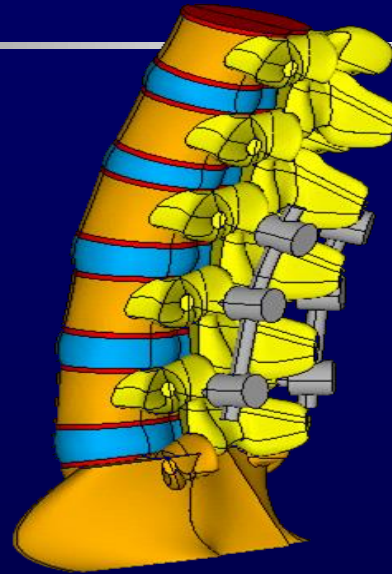
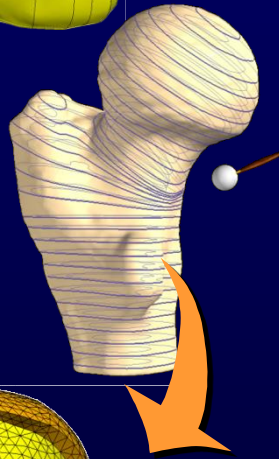
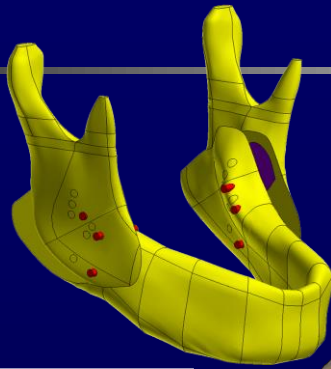

3D modeling for biological structure

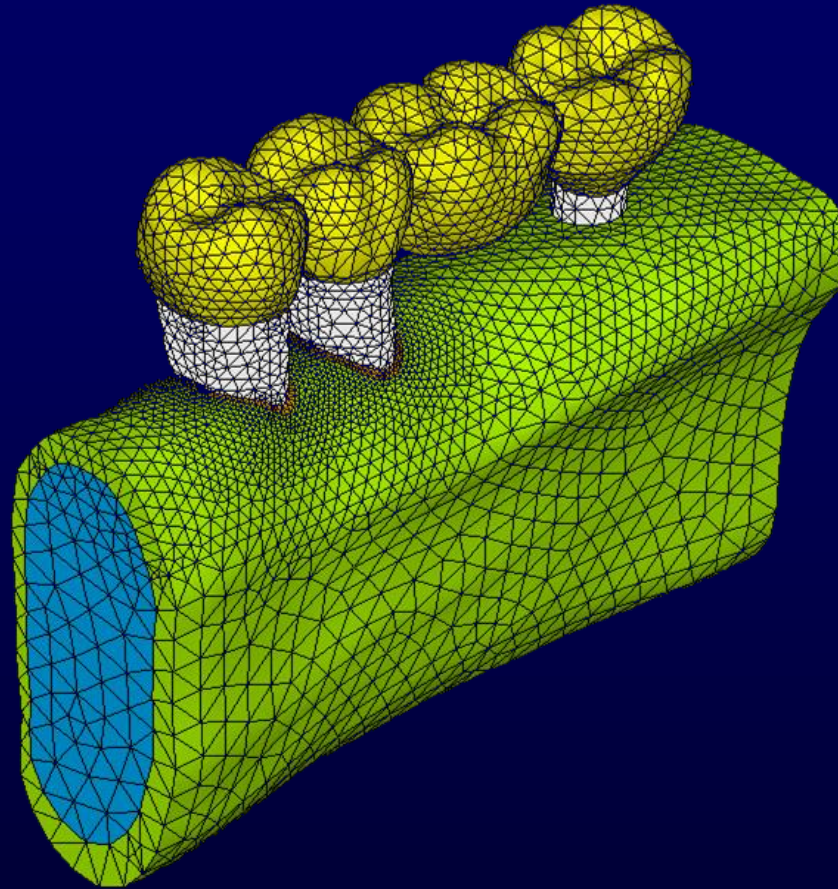

C.L. Lin, J.C. Wang*, S.T. Chen, "Evaluation of stress induced of implant type and number of splinted teeth in different periodontal supported tooth-implant supported FPDs: a nonlinear finite element analysis", *Journal of Periodontology*, Vol. 81, pp.121-130, 2010.

CAE key factors

❖ 電腦輔助分析 (Computer Aided Engineering, CAE)

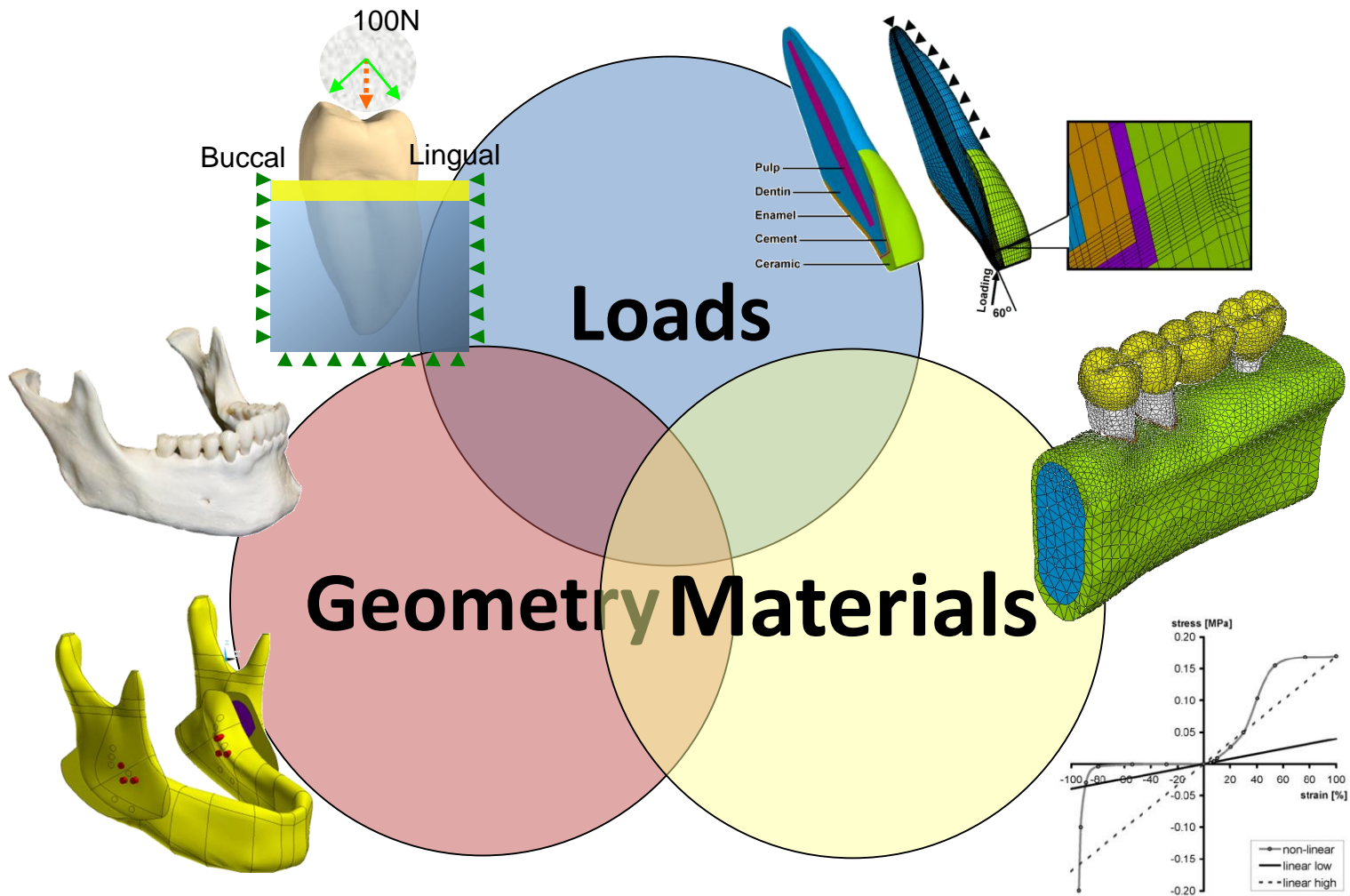

Non linear analysis

■ Material property

- Non-homogeneous, anisotropic
- Viscous-elastic, Hyperelastic (PDL)

■ PDL

Authors	Elastic modulus (MPa)	Poisson's ratio
Vollmer	0.05/0.22	0.3
Andersen	0.07/0.8-68.9/13.8	0.49/0.3-0.45/0.49
Yettram	0.18	0.49
Tanne	0.67	0.49
Williams	1.5/100	0-0.45
Korioth	2.5-3.2	0.45
Farah	6.9	0.45
Takahashi	9.8	0.45
Ree	50	0.49
Cook	68.9	0.49
Ko	68.9	0.45
Atmaram	171.6	0.45
Thresher	1379	0.45
Goel	1750	0.49

CAE-material

❖ 電腦輔助分析 (Computer Aided Engineering, CAE)

Materials

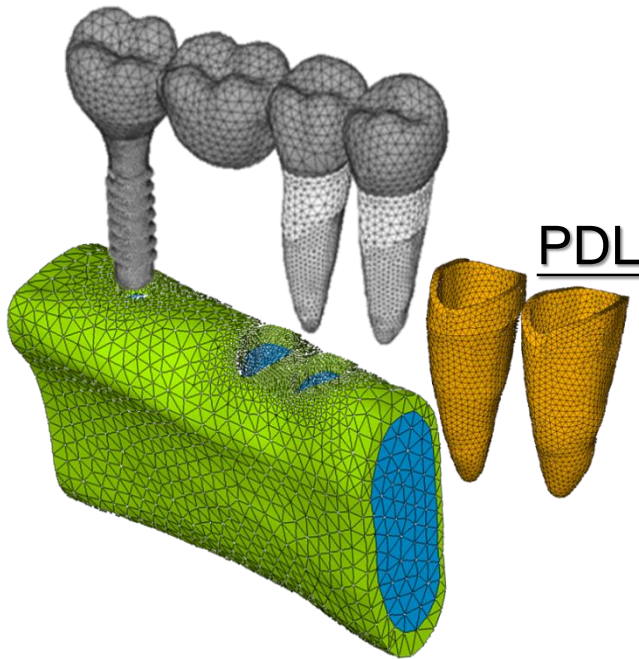

Nonlinear material property

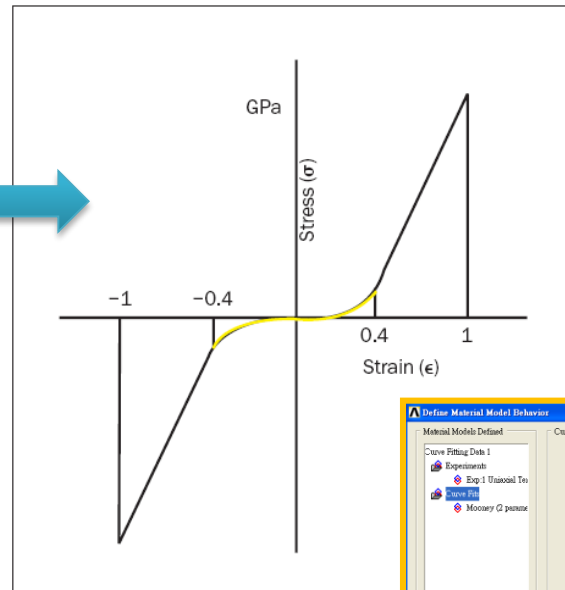

$$\sigma = 1.498246 \times 10^{-2} \epsilon^3$$

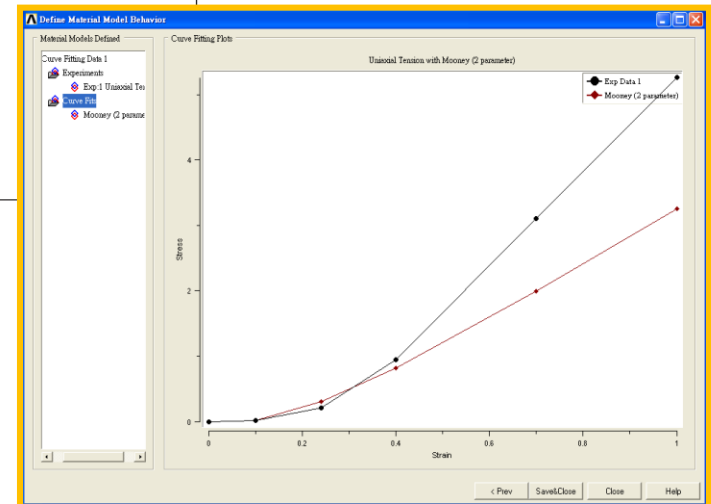

Material property simulation

CAE-material

❖ 電腦輔助分析 (Computer Aided Engineering, CAE)

Materials

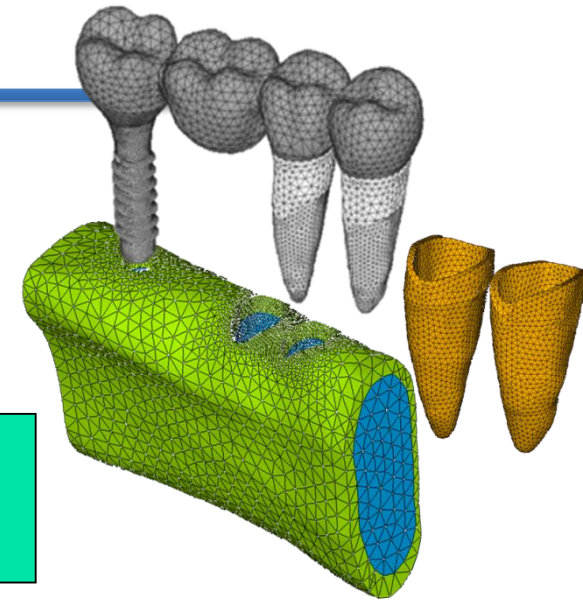

Hyper Max Dis = -10.31
Normal Max Dis = -1.23

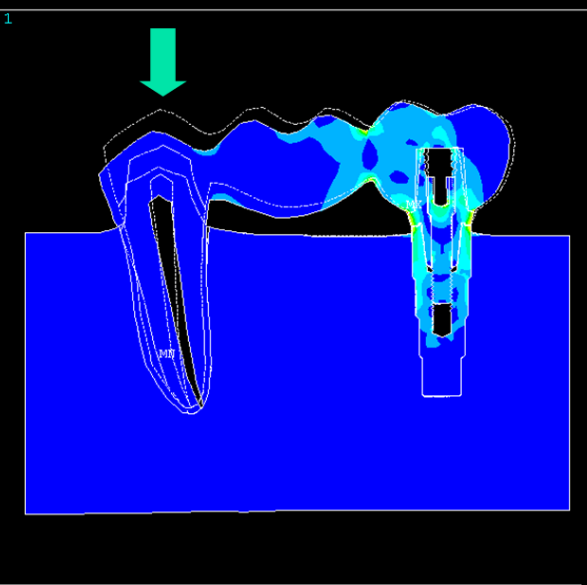

```
ANSYS 11.0  
APR 6 2009  
13:38:28  
NODAL SOLUTION  
STEP=1  
SUB =24  
TIME=1  
SEQV (AVG)  
PowerGraphics  
EFACET=1  
AVRES=Mat  
DMX =.01054  
SMN =.272E-04  
SMX =10.744  
.272E-04  
1.194  
2.388  
3.581  
4.775  
5.969  
7.163  
8.357  
9.55  
10.744
```

Displacement 及 stress
均有極大差異

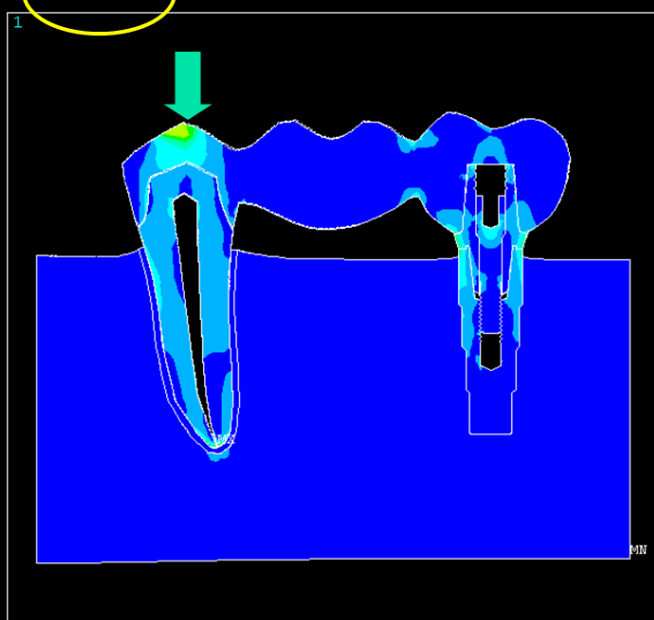

```
ANSYS 11.0  
APR 6 2009  
13:42:57  
NODAL SOLUTION  
STEP=1  
SUB =1  
TIME=1  
SEQV (AVG)  
PowerGraphics  
EFACET=1  
AVRES=Mat  
DMX =.621E-03  
SMN =.001249  
SMX =1.125  
.001249  
.126165  
.251081  
.375997  
.500913  
.625829  
.750745  
.875661  
1.001  
1.125
```

Easy to do, hard to do well!

Validation with experiments

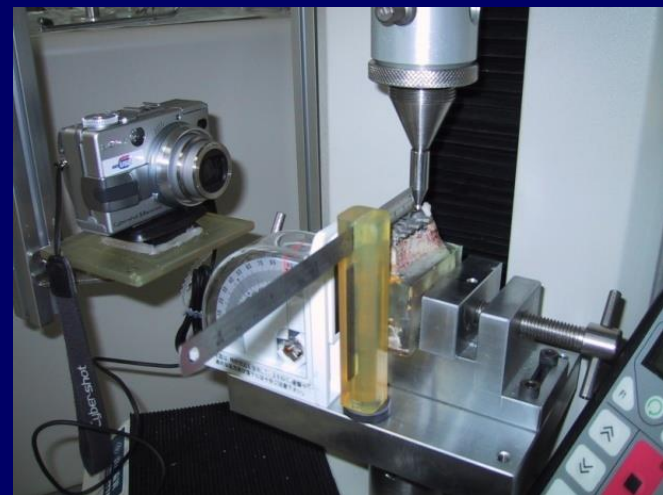
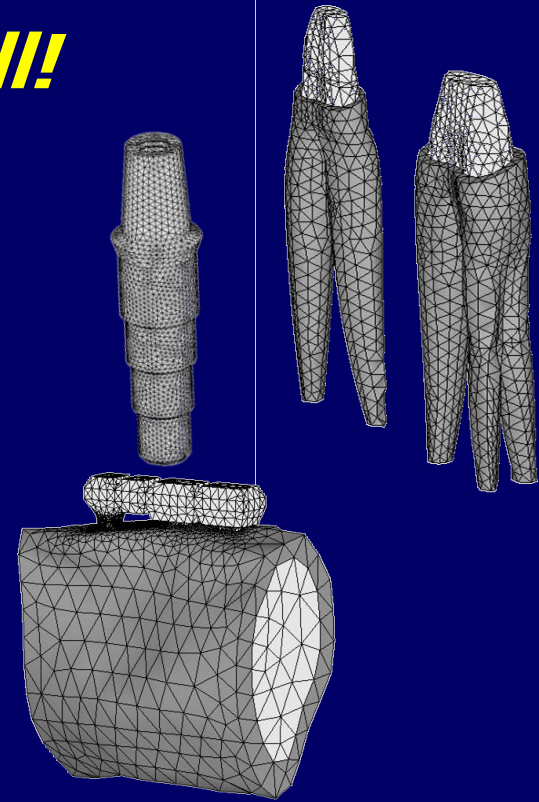

自然牙齒構造

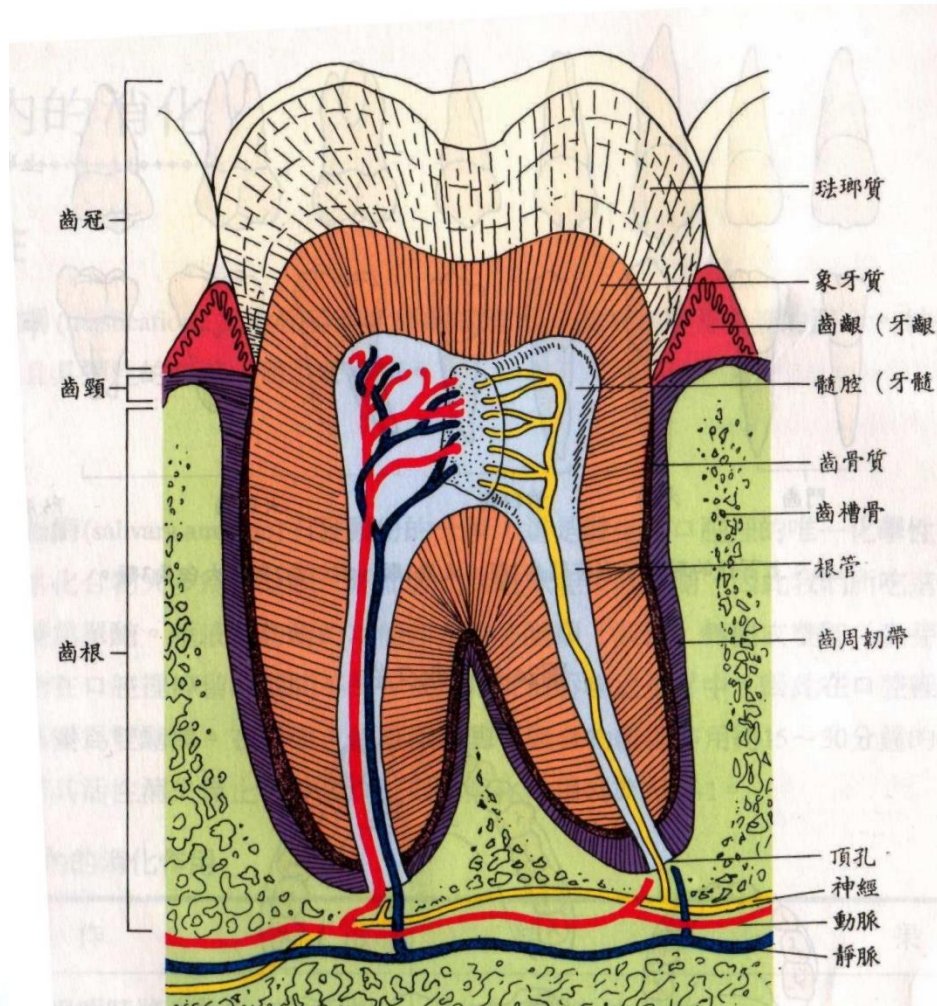

自然牙齒

- 第一套乳牙- 20顆
- 第二套恆牙- 32顆

齒槽骨

- 由膠質、礦物質、纖維蛋白和基質所組成。
- 牙齒脫落會發生骨吸收現象

何謂人工牙根？

- 以純鈦金屬或鈦合金人工牙根種植到缺牙區的齒槽骨
- 人工牙根與骨細胞產生緊密的結合(骨整合)
- 在人工牙根表面必須經過特殊的處理



Tooth Replacement with Dental Implants

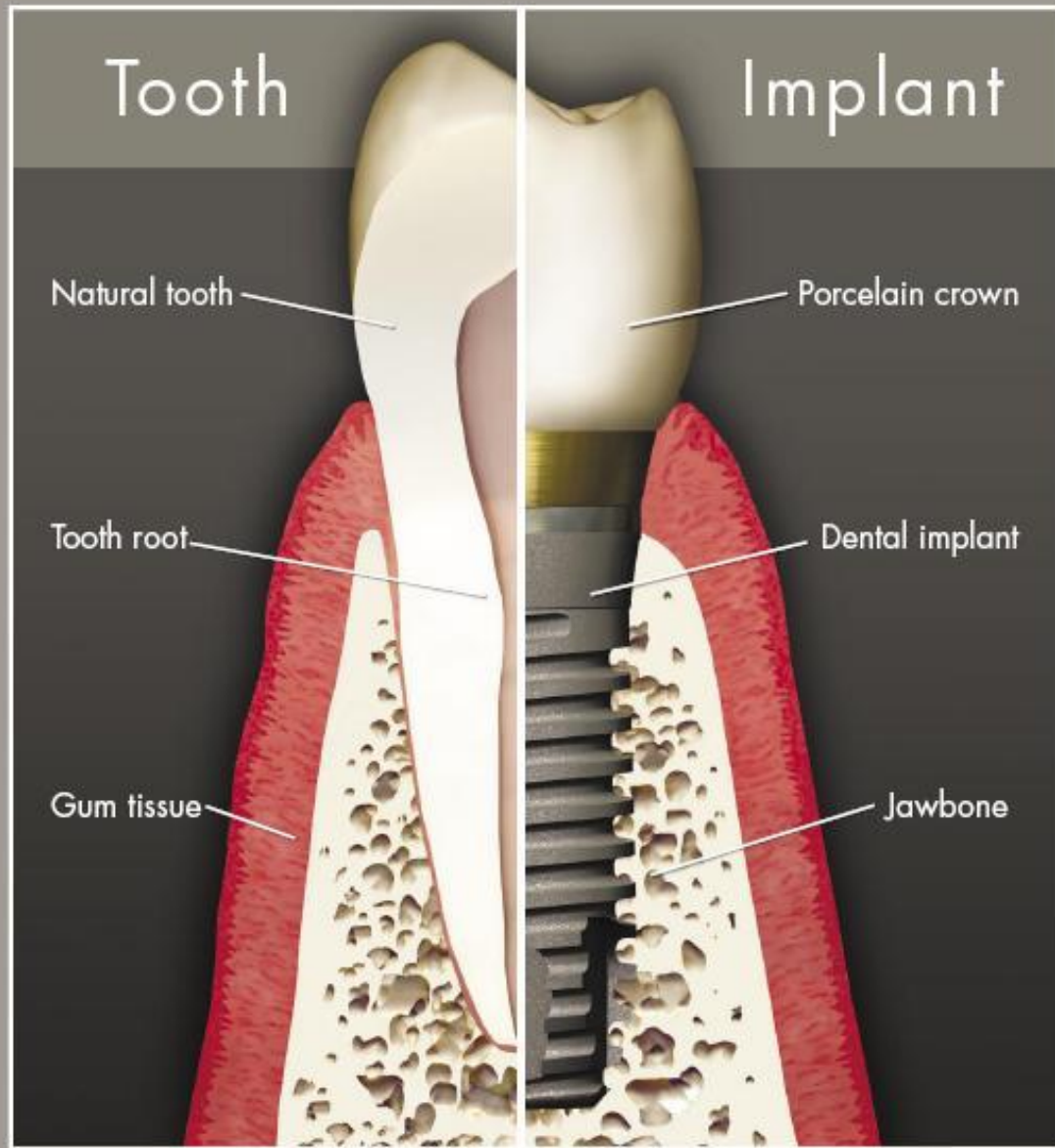

人工牙根簡要

● 人工牙根

● 定義

- 以人工替代物種植到缺牙區的齒槽骨以取代原本牙齒的功能

● 目的

- 恢復口腔中牙齒咀嚼之功能

● 骨整合機制

- 必須經過3至6個月人工牙根的表面與骨細胞產生緊密的結合

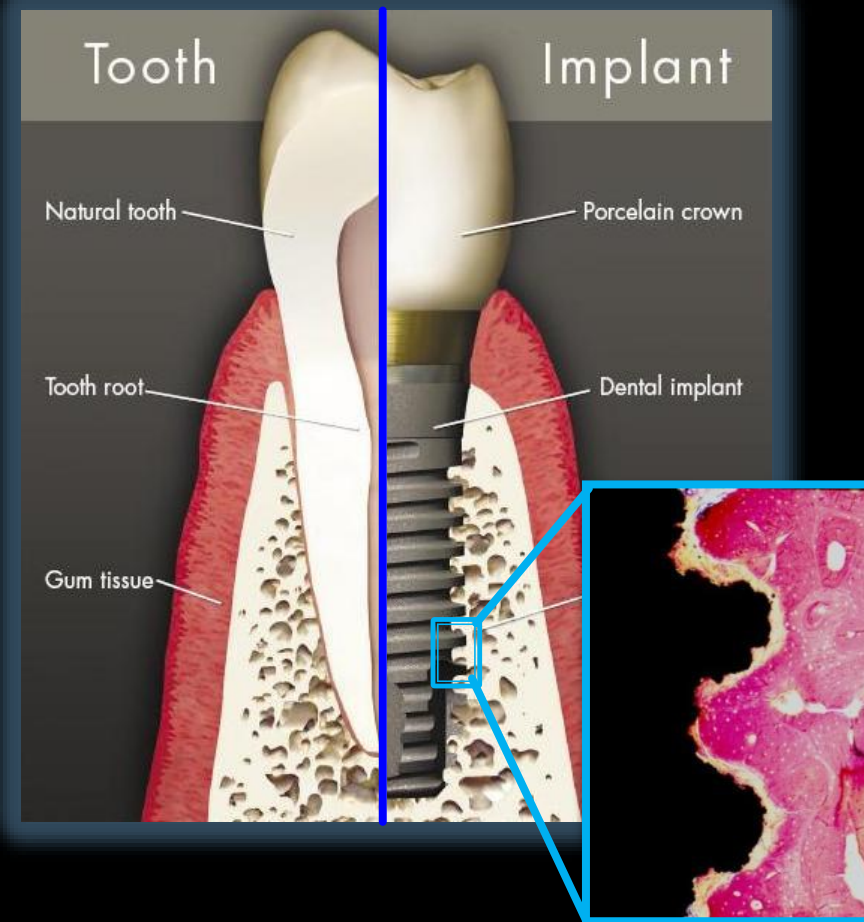

人工牙根成功條件

●人工牙根成功條件

- 初期：良好的骨整合效果
- 長期：避免骨整合流失

●影響骨頭受力之因素

●生物力學因素

- 人工牙根及支台外形設計
- 人工牙根植入形式
- 咬合力形式

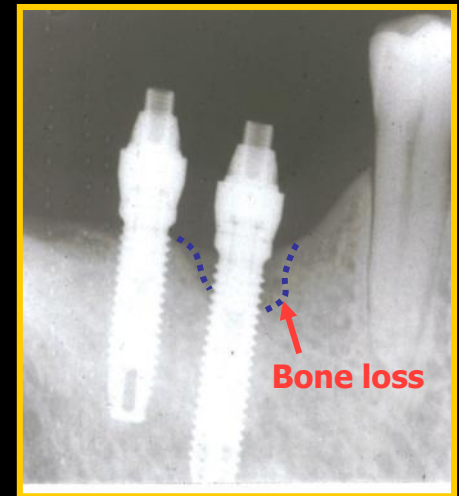
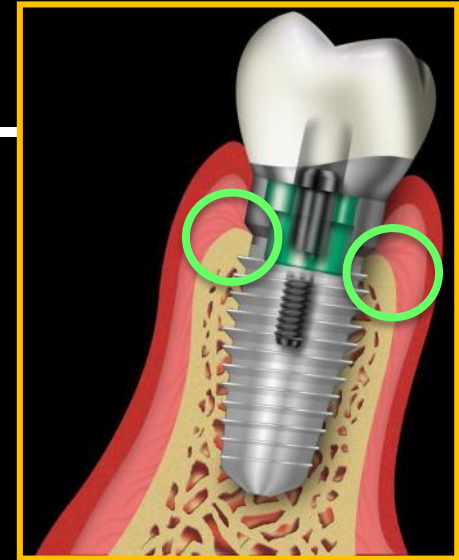

Dental Implant

Surgical classification

Feature classification

1 stage

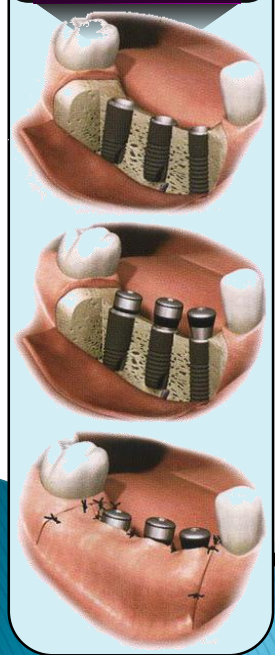

2 stage

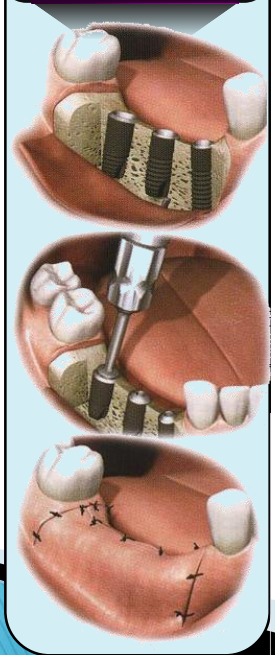

Immediate placement



1 piece



2 piece



3 piece

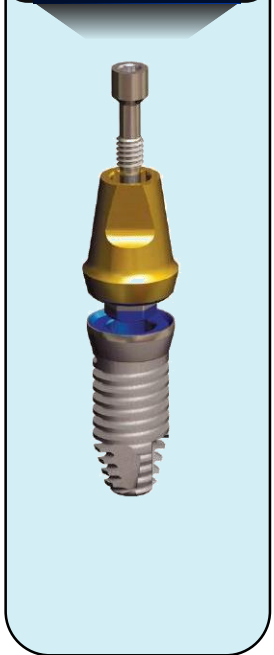

Success rate & factors

Immediate placement 80%
Traditional placement 95%

Initial stability

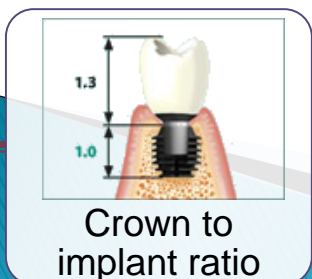
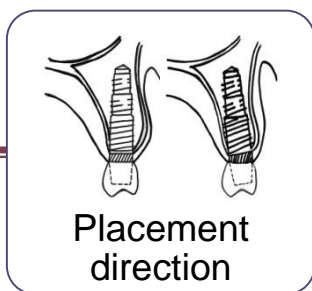
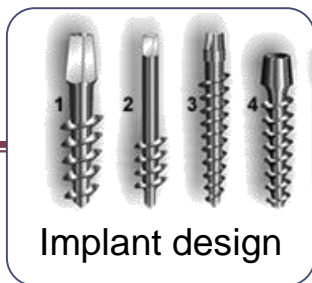

Bone situation

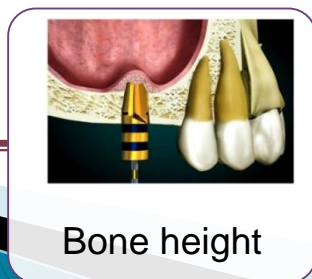
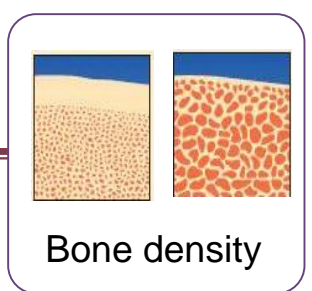
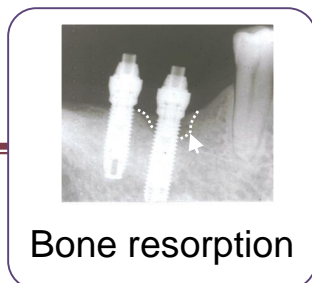

Clinical factor



Patient habits

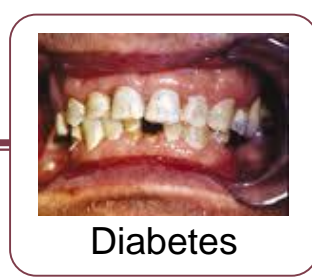
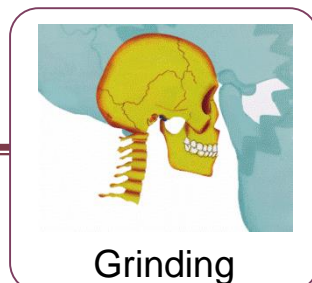

Biomechanical factors

Initial stability

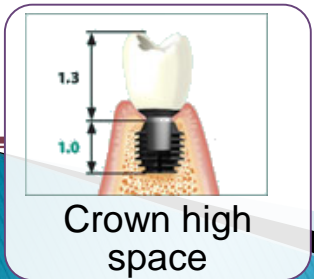
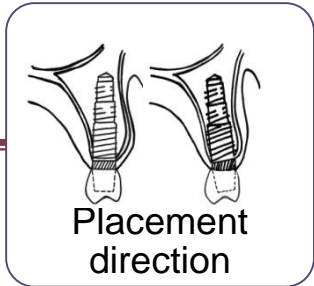
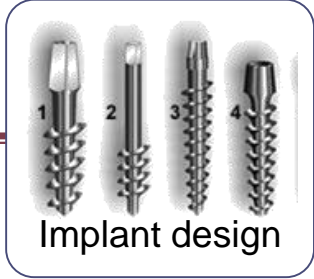

Bone situation

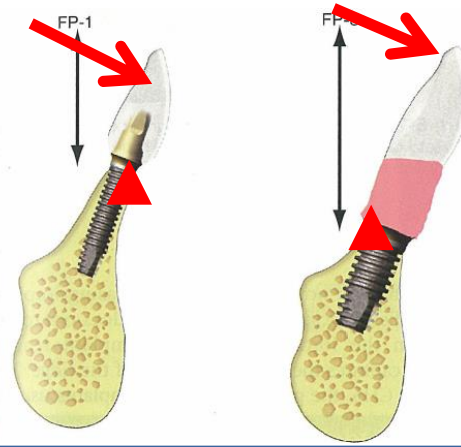
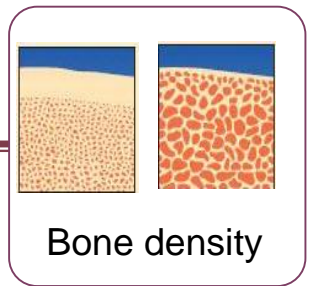
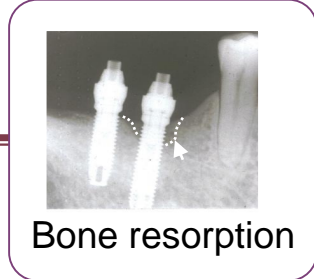

CHS 會產生“槓桿”現象
越高的CHS會產生越大的應力

CHS: Crown Height Space 冠高空間

生物力學&生理機械

Biomechanics & Mechano biology

- 人工牙根設計
- 骨質流失
- 骨質密度



病患生理&醫師考量

- 植體植入位置
- CHS
- 牙周狀態 / 骨質密度

生物力學&生理機械-人工牙根設計綱要

巨觀考量

連結器 (Connection)

頸部設計 (Crest design)

主體螺牙 (Body thread)

植體外型 (Implant shape)

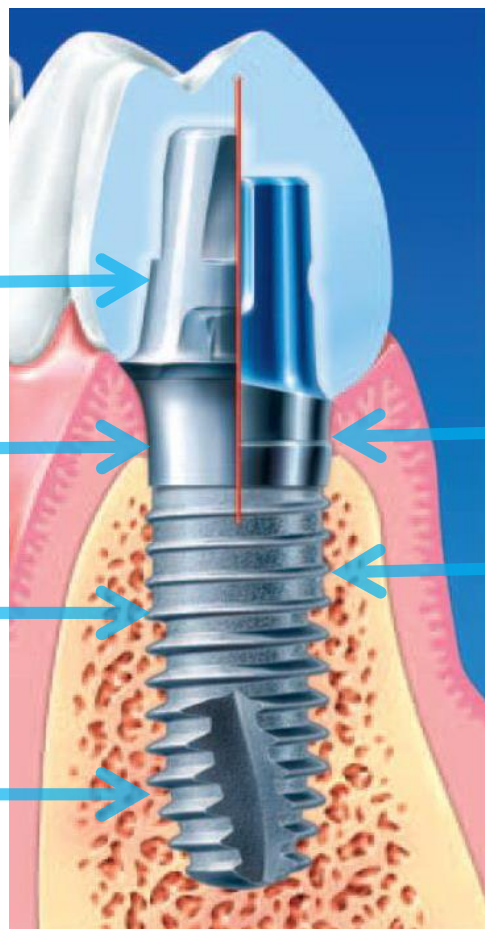

微觀考量

近端螺紋 (Proximal thread)

表面處理 (Surface treatment)

人工牙根設計 (1/2)

	Nobel Biocare	Straumann (ITI)	Innovations (3i)	Densply (Frialit-2)	Astra Tech (Astra)
植體圖					
植體外型	斜錐狀	圓柱狀	斜錐狀	階梯狀	斜錐狀
主體螺牙	深螺紋 自攻設計	淺螺紋	深螺紋 自攻設計	無	深螺紋 自攻設計
頸部設計	無	無	Platform switching	無	Platform switching

人工牙根設計 (2/2)

	Nobel Biocare	Straumann (ITI)	Innovations (3i)	Densply (Frialit-2)	Astra Tech (Astra)
植體圖					
連結器設計	三瓣式 搭配螺絲	Morse taper	內六角 搭配螺絲	內六角 搭配螺絲	內十二角 搭配螺絲
近端細螺紋	有	無	無	無	有

醫學影像掃描及處理

● 醫學影像掃描

● 上/下顎骨

- 健康40歲男性
- 小白齒區無牙狀態
- CT掃描間隔：1mm

● 人工牙根

● 廠牌：

- Nobel Biocare (Replace)
- Straumann (ITI)
- Biomet (3i)
- Densply (Frialit-2, XiVE)
- Astra Tech (Astra)

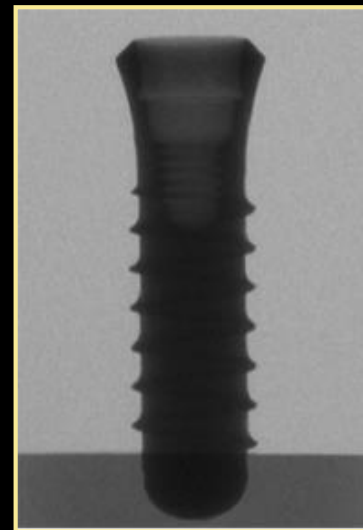
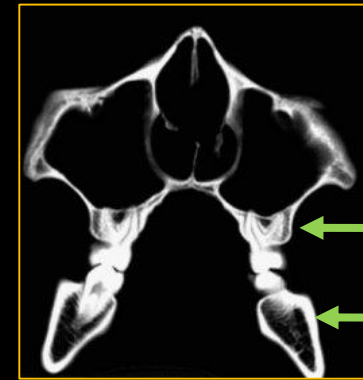

醫學影像掃描及處理

● 上顎骨醫學影像掃描及處理

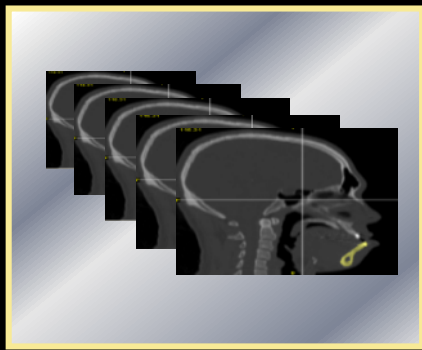

醫學影像處理

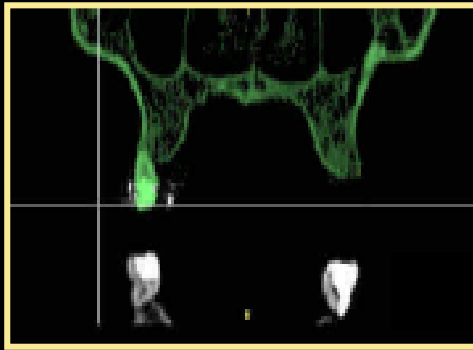

閾值調整及部位選取

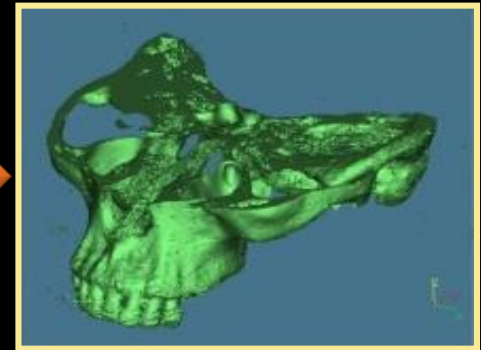

影像重組

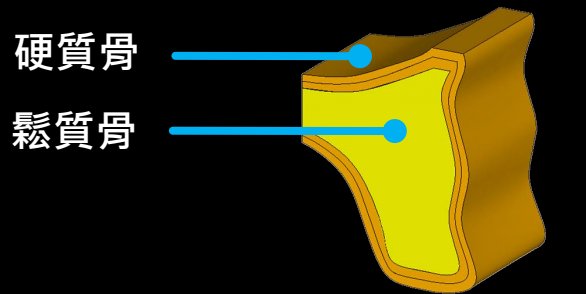

上顎第二小白齒區
顎骨外型建構

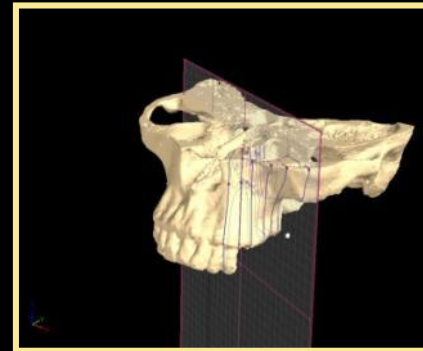

輪廓外形擷取

電腦輔助工程設計(CAD)

五大廠牌植體模型建構

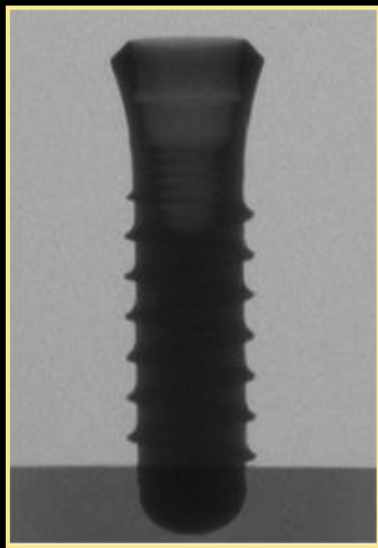

醫學影像處理

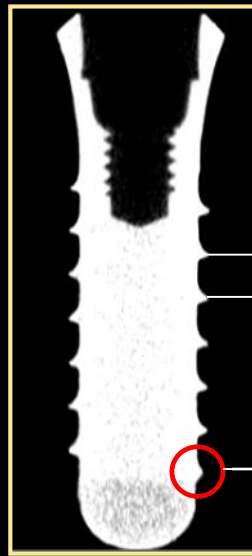

各部位尺寸量測

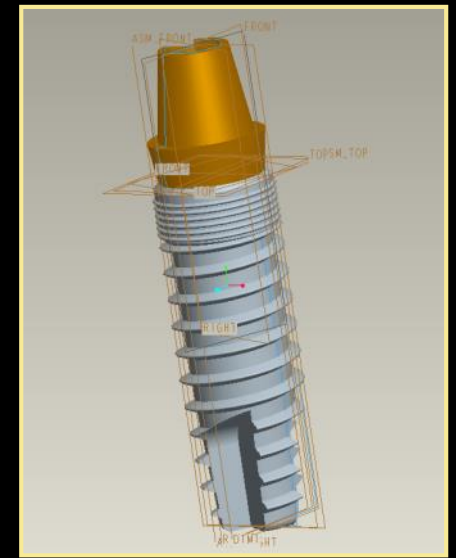
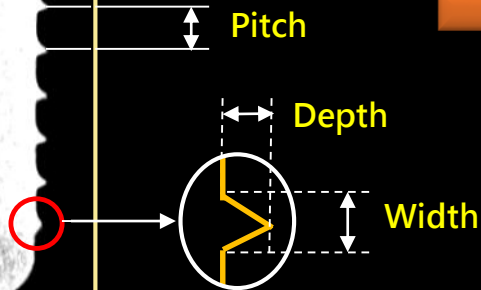

電腦輔助設計 (CAD)

設計 (三瓣搭配螺絲)

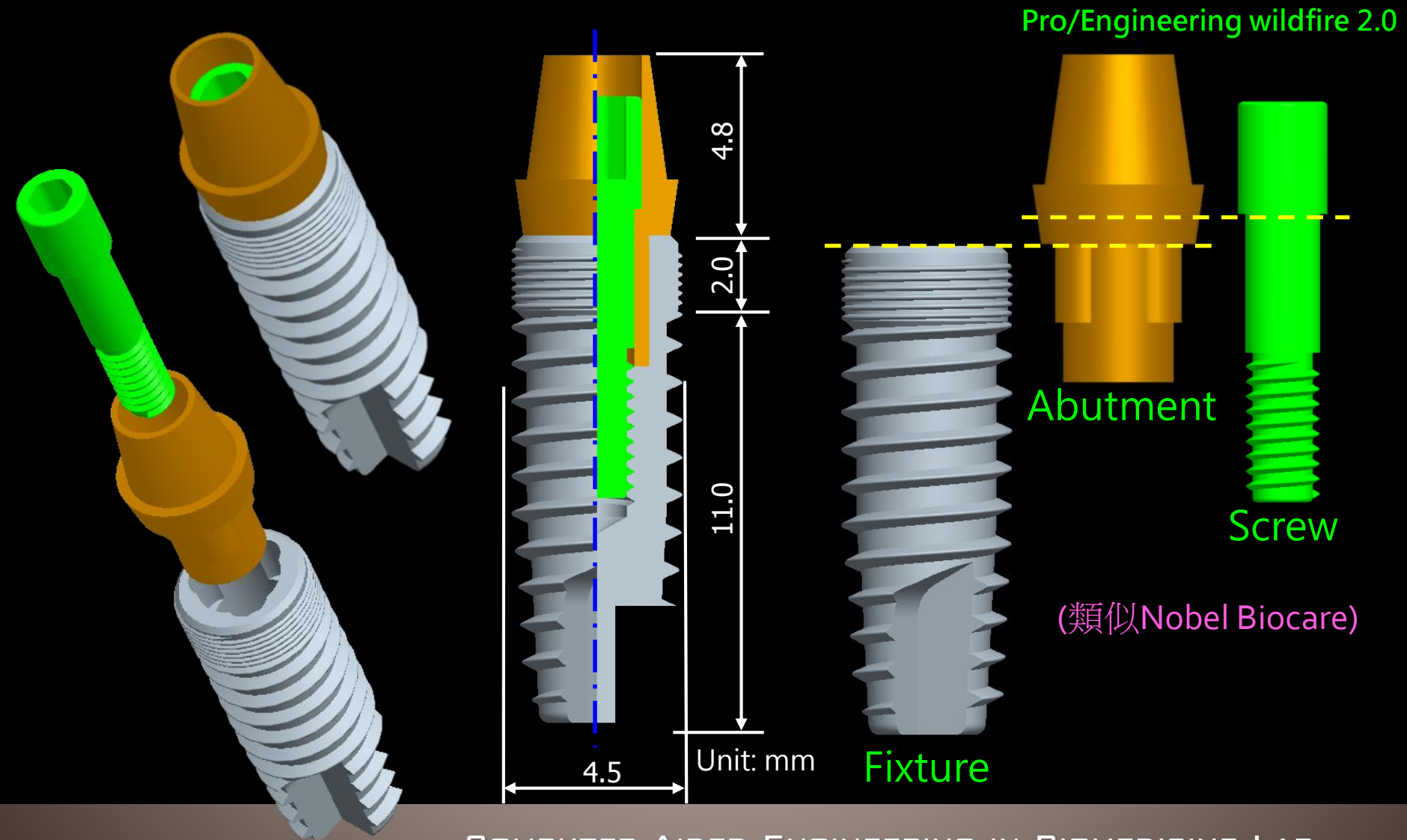

電腦輔助工程設計(CAD)

●人工植體模型

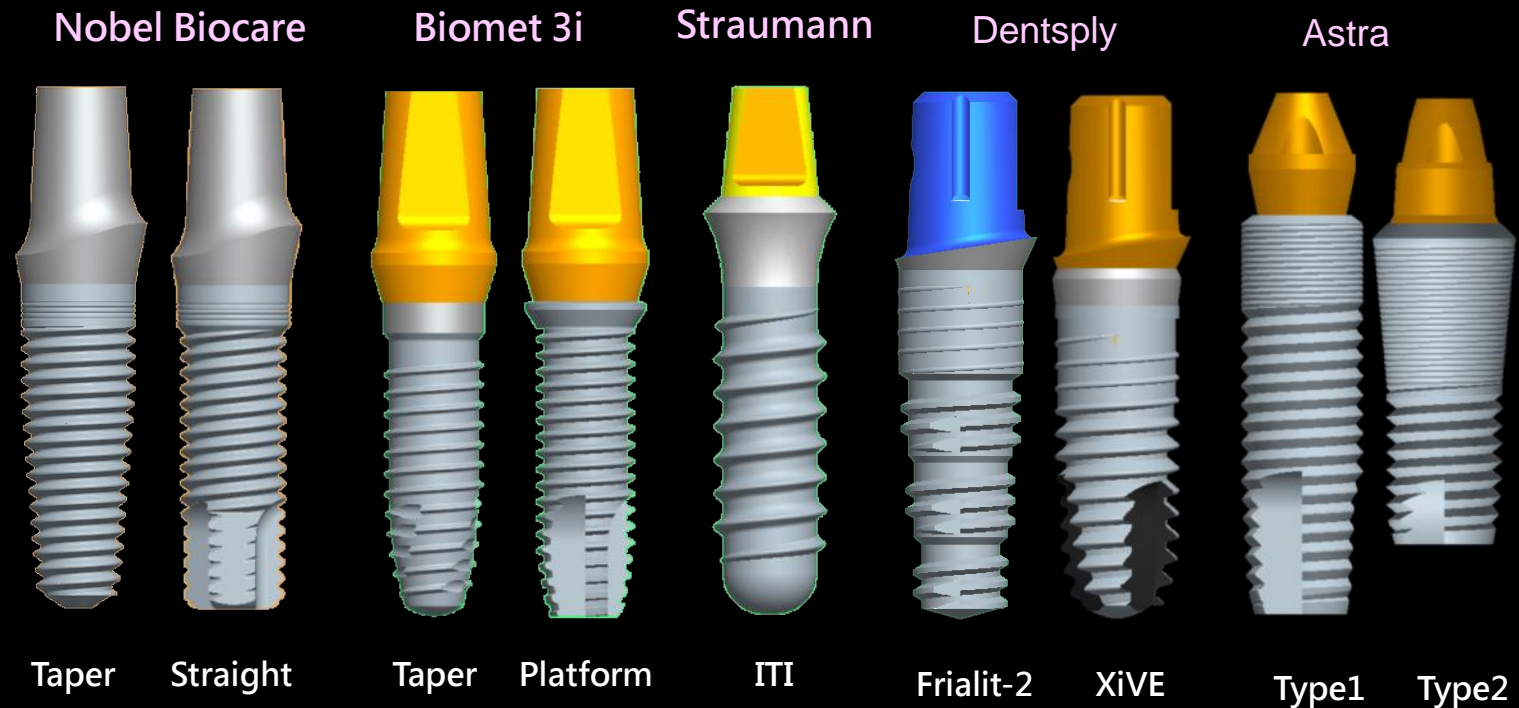

有限元素模型建構

- 上顎骨與人工牙根模型組合
- 各部位模型位置確立及布林運算

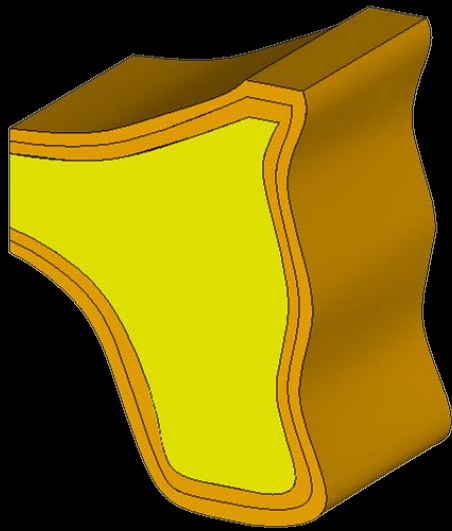

上顎骨模型



人工植體模型

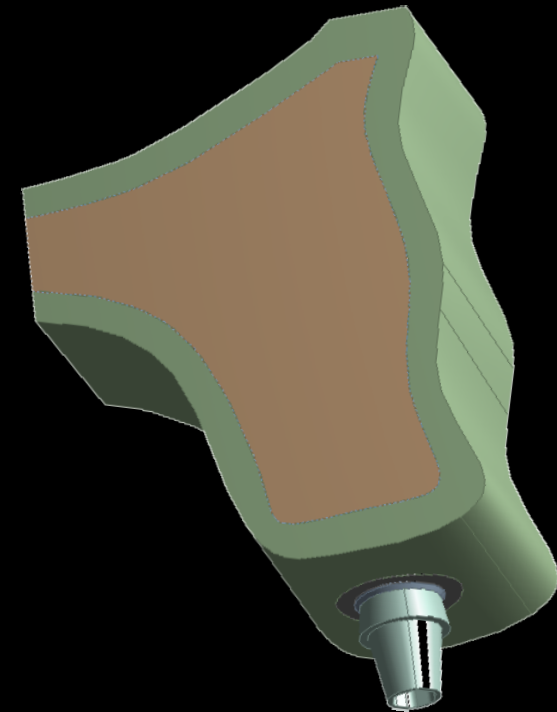

顎骨/人工植體模型

有限元素非線性模擬分析

● 模型網格化

- 使用三維四面體十節點元素(Solid 92)進行自由化網格

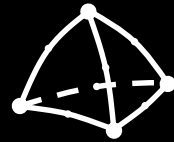

● 材料特性給定

- 硬質骨、鬆質骨及植體皆為等向均質材料

	彈性係數 (MPa)	樸松比
■ 硬質骨	14700	0.3
■ 鬆質骨	1470	0.3
■ 鈦合金	110000	0.35

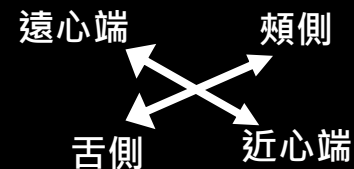
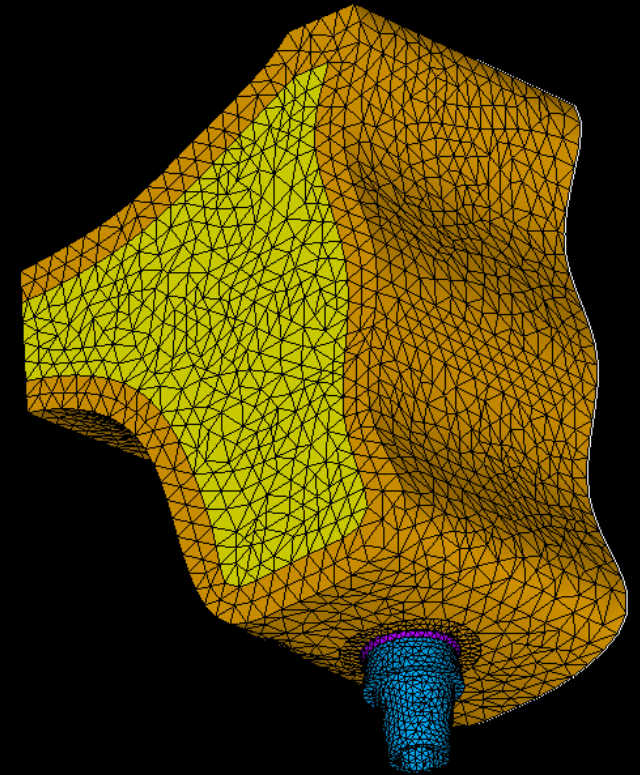

有限元素非線性模擬分析

- 邊界條件給定

- 近遠心端處節點自由度為零

- 負載條件給定

- 軸向負載：100N
- 側向負載：100N

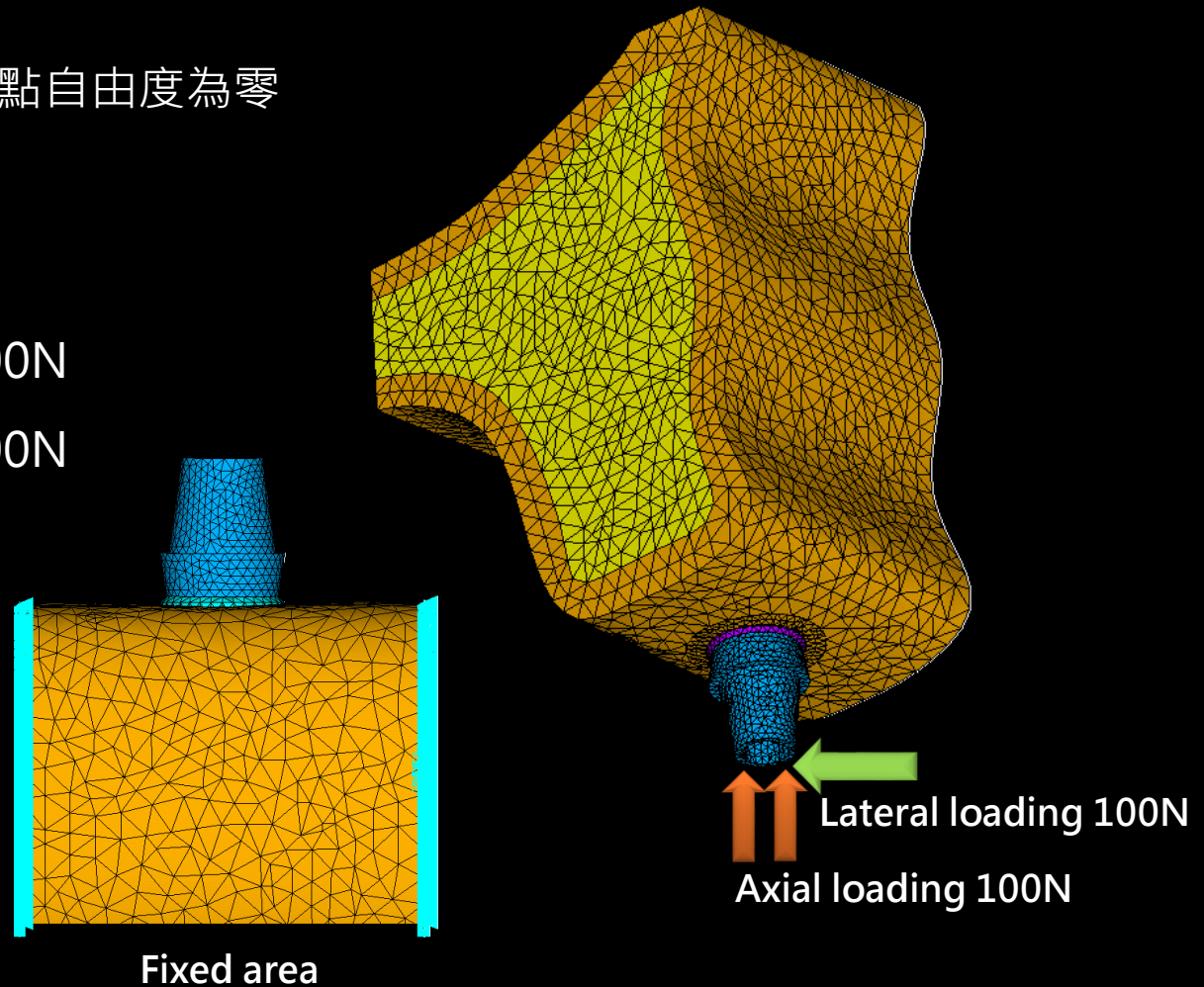

模擬分析觀察數值

● 人工牙根成功條件

- 避免骨整合流失
- 避免植體元件斷裂



● 觀察結果

● 骨頭應變值

- 骨頭應變值(ustrain)超過4000時

Frost. et. 2004

● 人工植體應力值

- 鈦金屬之破壞強度為 1000 MPa

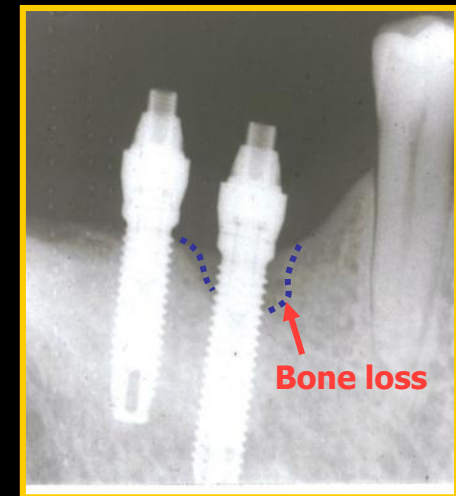

有限元素模擬分析結果(上顎)

● 植體應力分佈圖-側向負載

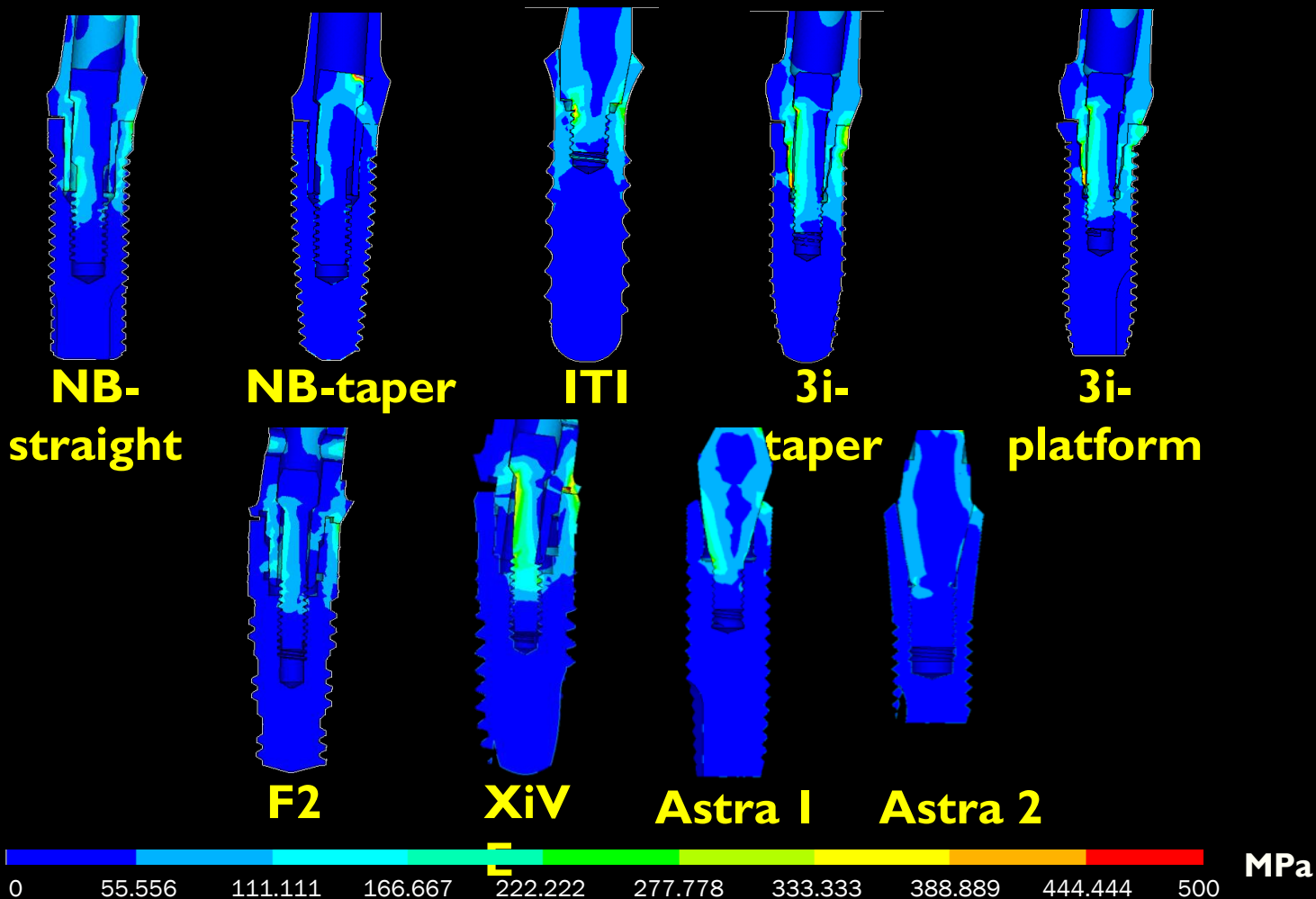

有限元素模擬分析結果-側向負載之植體應力值

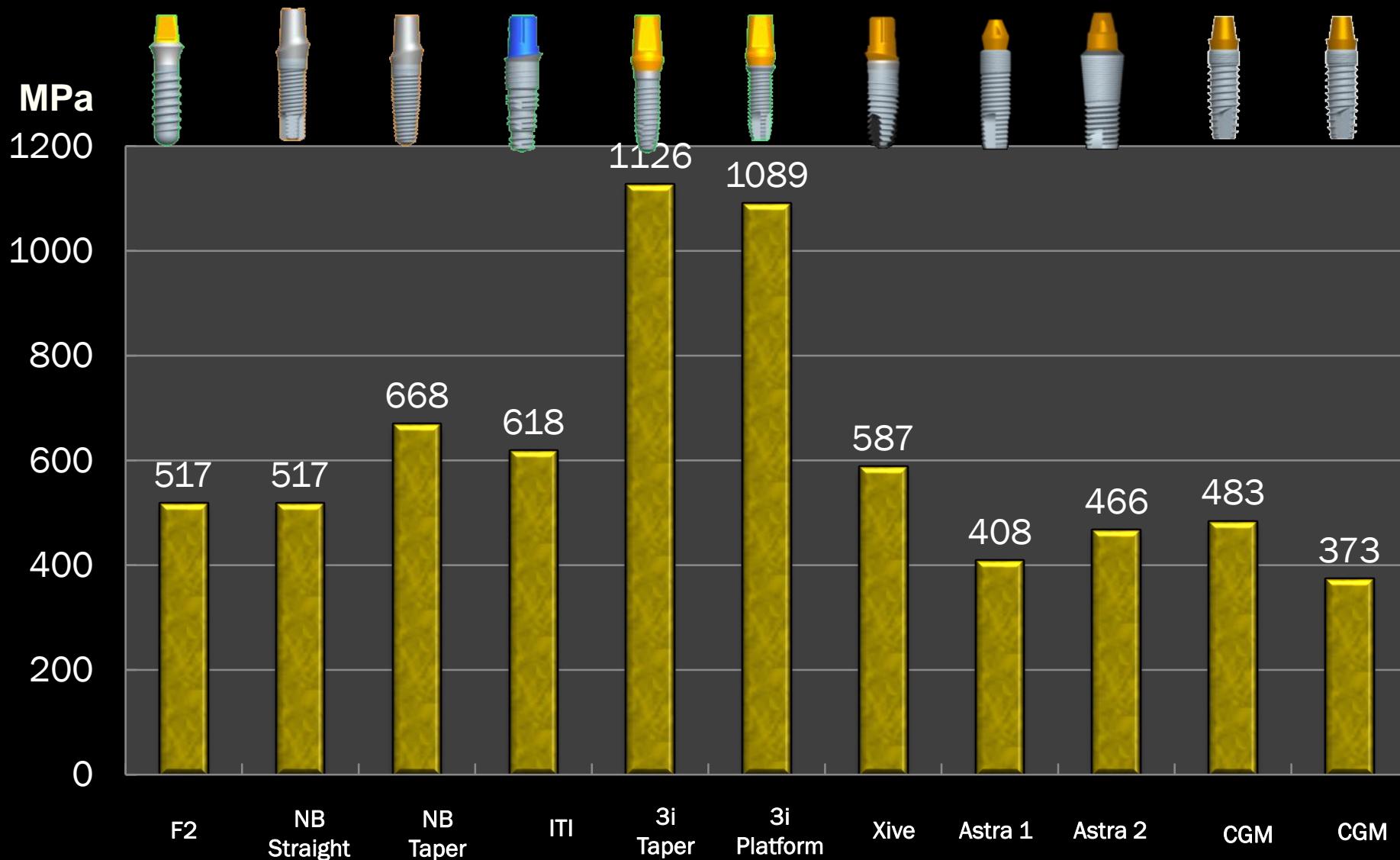

European Journal of Oral Sciences, Vol. 115, pp.408-416, 2007.

有限元素模擬分析結果(上顎)

● 骨質應變分佈圖-側向負載

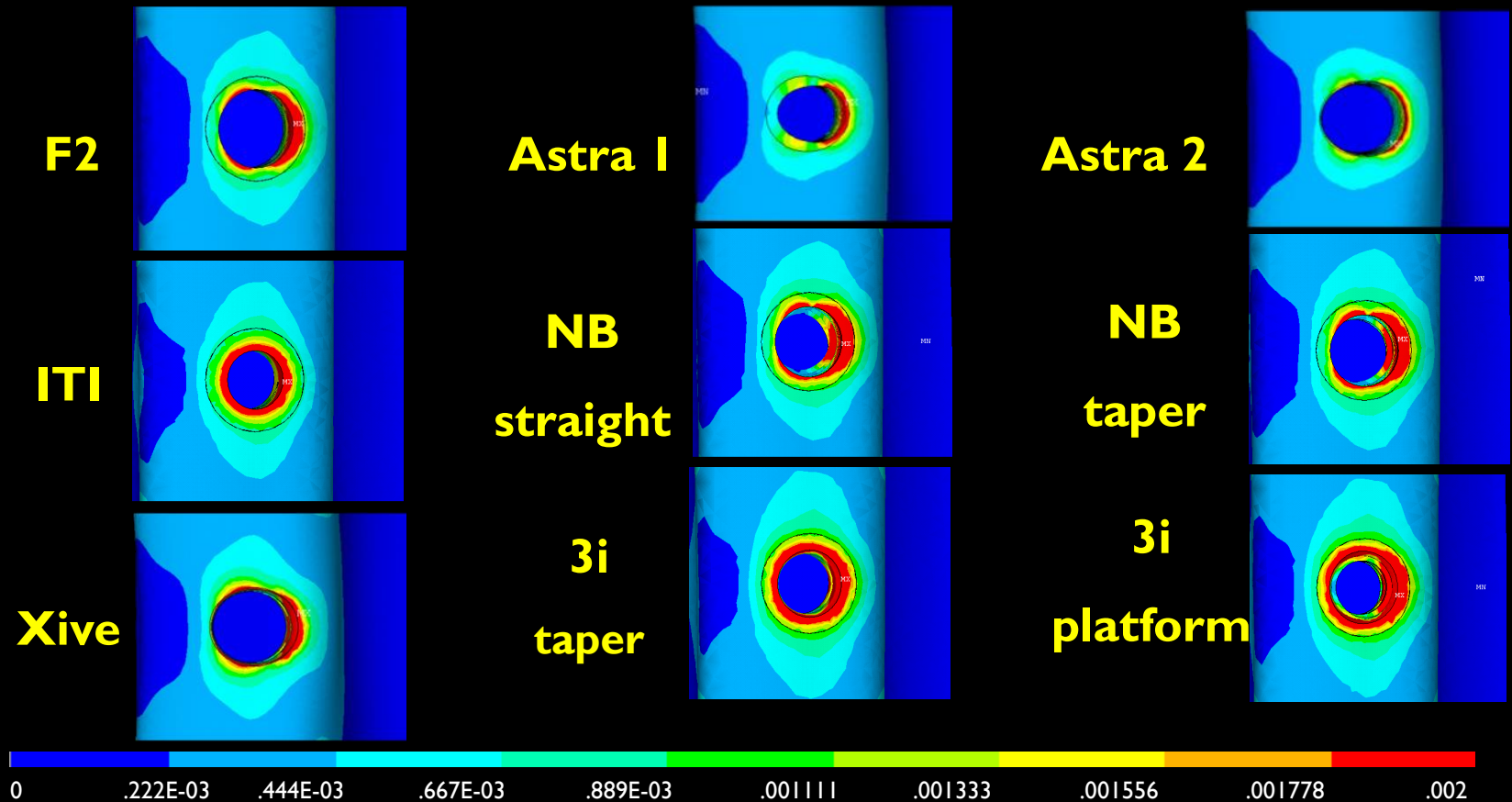

有限元素模擬分析結果-側向負載之骨質應變值

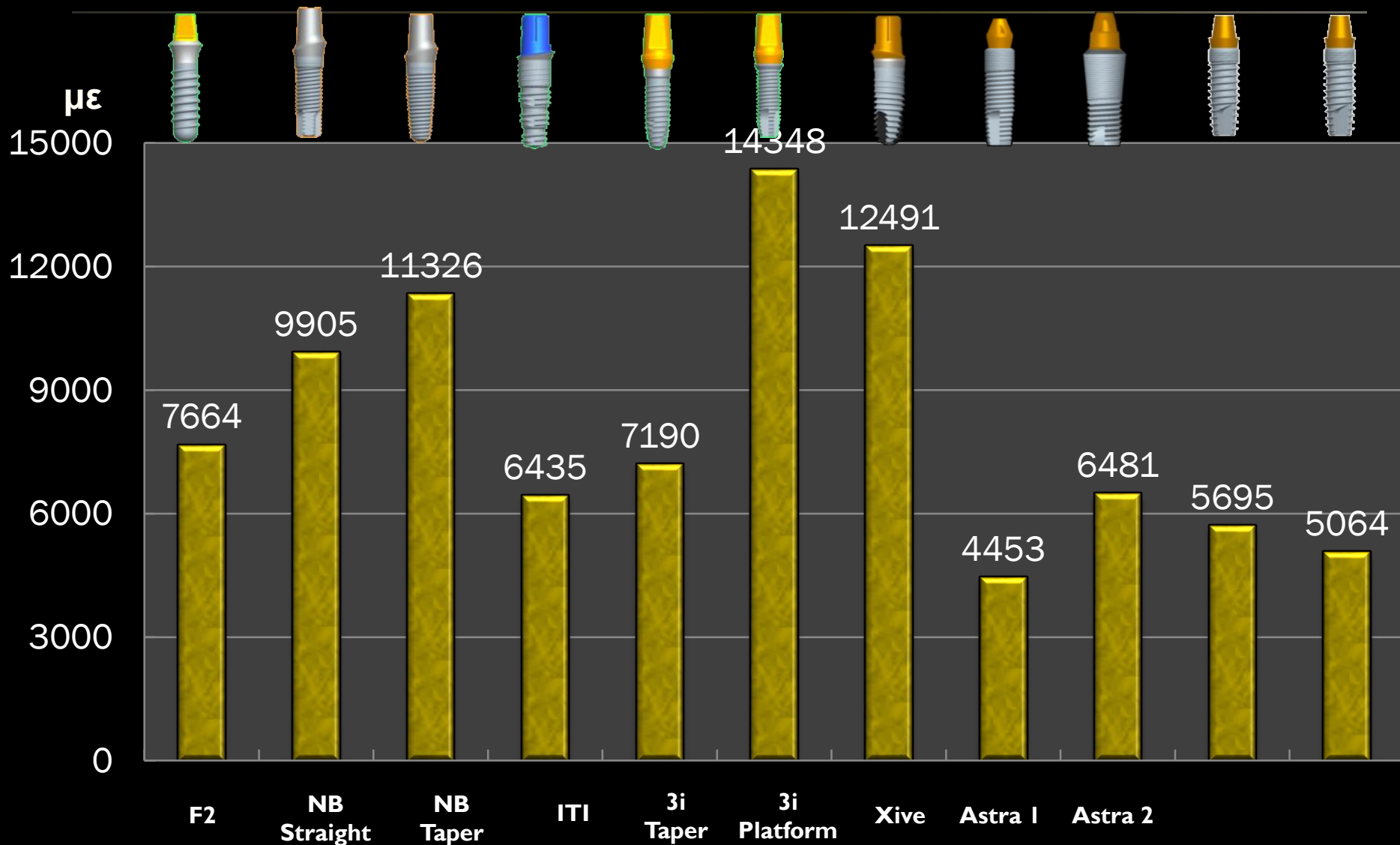

Summary of Current Medical Device Premarket Review Processes

Country	Premarket Review Documentation	Requirements	Recognized Standards
中華民國	查驗登記	醫療器材查驗登記準則/STED 體外診斷醫療器材查驗登記審查須知	衛生署醫療器材採認標準
United States	510(k) PMA STED Pilot	Substantial Equivalence/FDA Special Controls PMA+QS Inspection Essential Principles	FDA Recognized Standards
EU+EFTA	Technical File Review	AIMD/MDD/IVDD Essential Principles Annex II: Full QS	Harmonized Standards
Australia	GHTF MD STED GHTF IVD STED	Essential Principles	TGA Recognized Standards
Canada	Technical File STED (III & IV)	Essential Principles	Health Canada Recognized Standards
Japan	醫療機器承認審查 STED (III & IV)	醫療機器基本要件(Essential Requirements)	認證基準 承認基準 醫療機器審查指南 JIS

資料來源：工研院量測中心醫療器材驗證室

產業現況與問題 - 高階醫材(Class II, III)產業缺口與解決方案

臨床機構所面臨問題

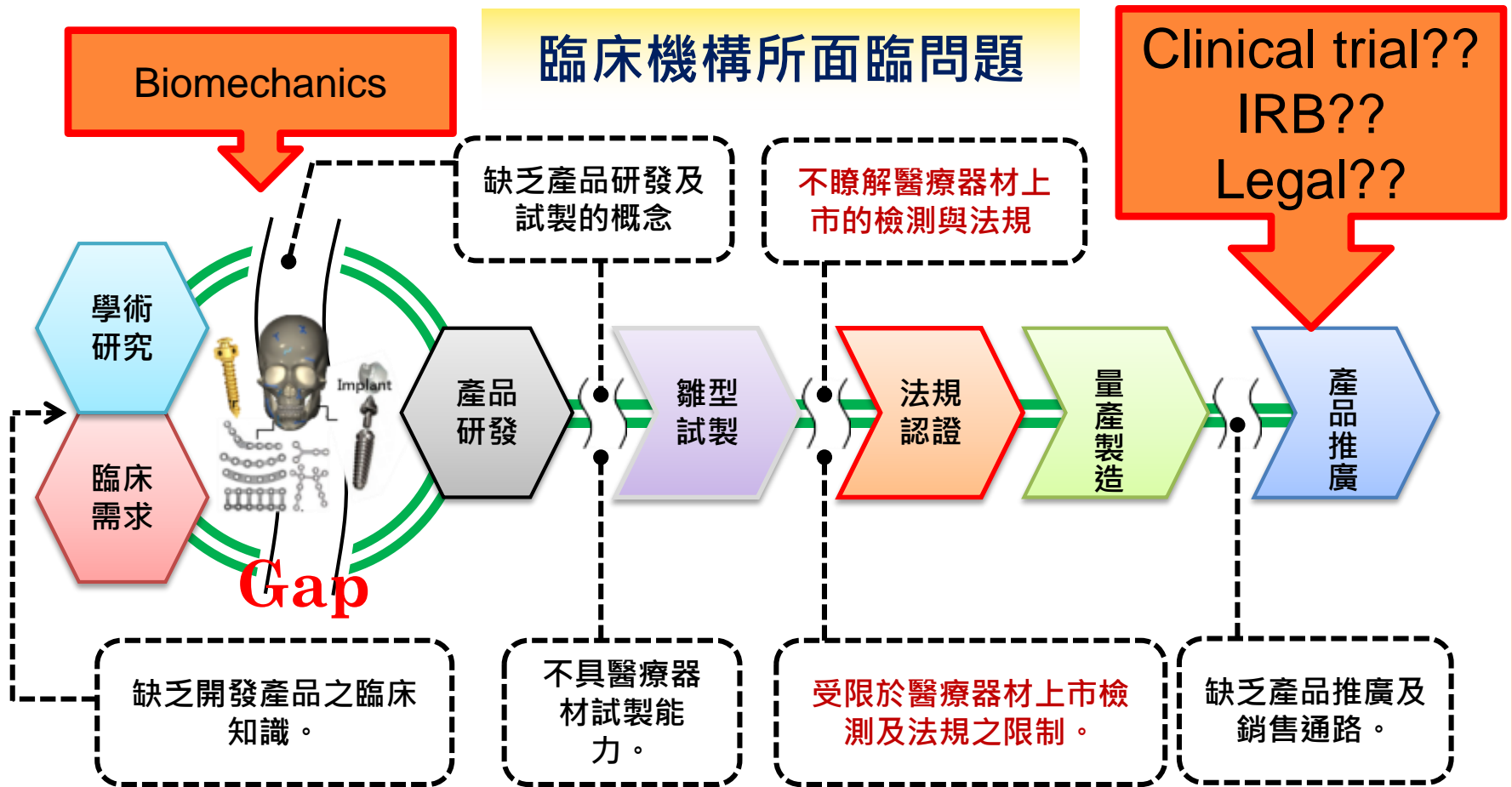

醫療器材產業所面臨問題





Optimal? Biomechanics (CAE/FEA)?

探討臨床參數不夠多？



Dental Implant Approval by FDA

[New Search](#)

[Back To Search Results](#)

Device Classification Name [Implant, Endosseous, Root-Form](#)
510(K) Number K122864
Device Name ZUGA DENTAL IMPLANT SYSTEM
Original Applicant ZUGA MEDICAL, INC.
 P.o. Box 566
 Chesterland, OH 44028 2141
Original Contact Karen E Warden, Phd
Regulation Number [872.3640](#)
Classification Product Code [DZE](#)
Subsequent Product Code [NHA](#)
Date Received 08/31/2012
Decision Date [04/08/2013](#)
Decision [Substantially Equivalent \(SE\)](#)
Classification Advisory Committee Dental
Review Advisory Committee Dental
Summary [Summary](#)
Type Traditional
Reviewed By Third Party No
Expedited Review No
Combination Product No

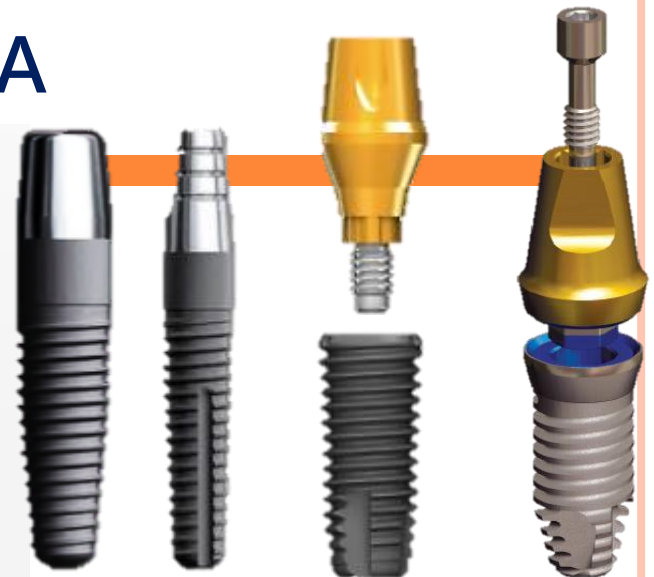

1 piece

2 piece

3 piece

[New Search](#)

[Back To Search Results](#)

Device Implant, Endosseous, Root-Form
Regulation Description Endosseous dental implant.
Regulation Medical Specialty Dental
Review Panel Dental
Product Code DZE
Submission Type 510(k)
Regulation Number [872.3640](#)
Device Class 2
Total Product Life Cycle (TPLC) [TPC Product Code Report](#)
GMP Exempt? No

Recognized Consensus Standards

- ISO 10993-14 First edition 2001-11-15 [Biological evaluation of medical devices - Part 14: Identification and quantification of degradation products from ceramics](#)
- ISO 14801 Second edition 2007-11-15 [Dentistry-Implants-Dynamic fatigue test for endosseous dental implants](#)
- ISO 7405 Second edition 2008-12-15 [Dentistry - Evaluation of biocompatibility of medical devices used in dentistry](#)
- ASTM F2024-10 [Standard Practice for X-Ray Diffraction Determination of Phase Content of Plasma-Sprayed Hydroxyapatite Coatings](#)
- AAMVANS/ISO 10993-14:2001(R) 2011 [Biological evaluation of medical devices - Part 14:](#)

Dental Implant Approval by FDA

- Mechanical : ISO 14801
- Biocompatibility : ISO 7405, ISO 10993
- Coating : ASTM F2024-10, ASTM F1377-08
- Forging : ISO 5832-2, ISO 5832-3, ISO 5832-11
- Ceramic : ISO 9693, ISO 10993-14



力學測試



材料測試



塗層及生物相容性測試

Dental Implant Fatigue Test-ISO14801

- **Purpose** : Life limitation
- **Machine** : Fit ISO 7500-1及 ISO 4965 (accuracy)
- **Setup** :
 - Incline 30 degree
 - Embedding material >3GPa
- **Static test** :
 - Load : 1 min/mm
- **Fatigue test** :
 - 80%,70%,60%,50%,40% of Static fracture load
 - Sine wave
 - Frequency : 15 HZ
 - Cycles : 5,000,000 cycles

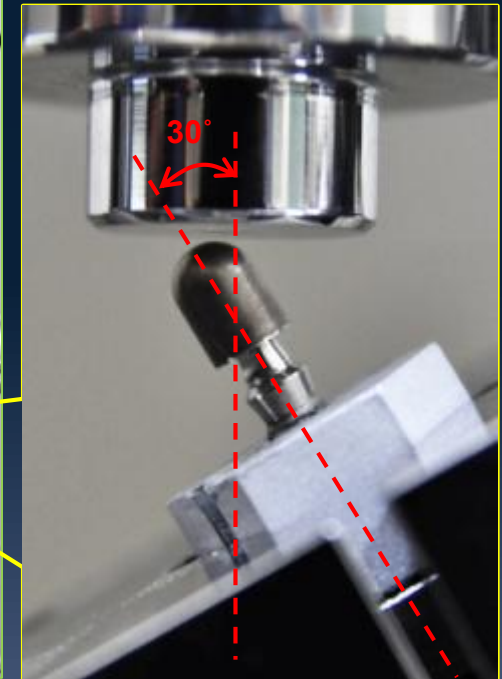

Dental Implant Fatigue Test-ISO14801

- **Static testing**
 - **Failure load (N)**

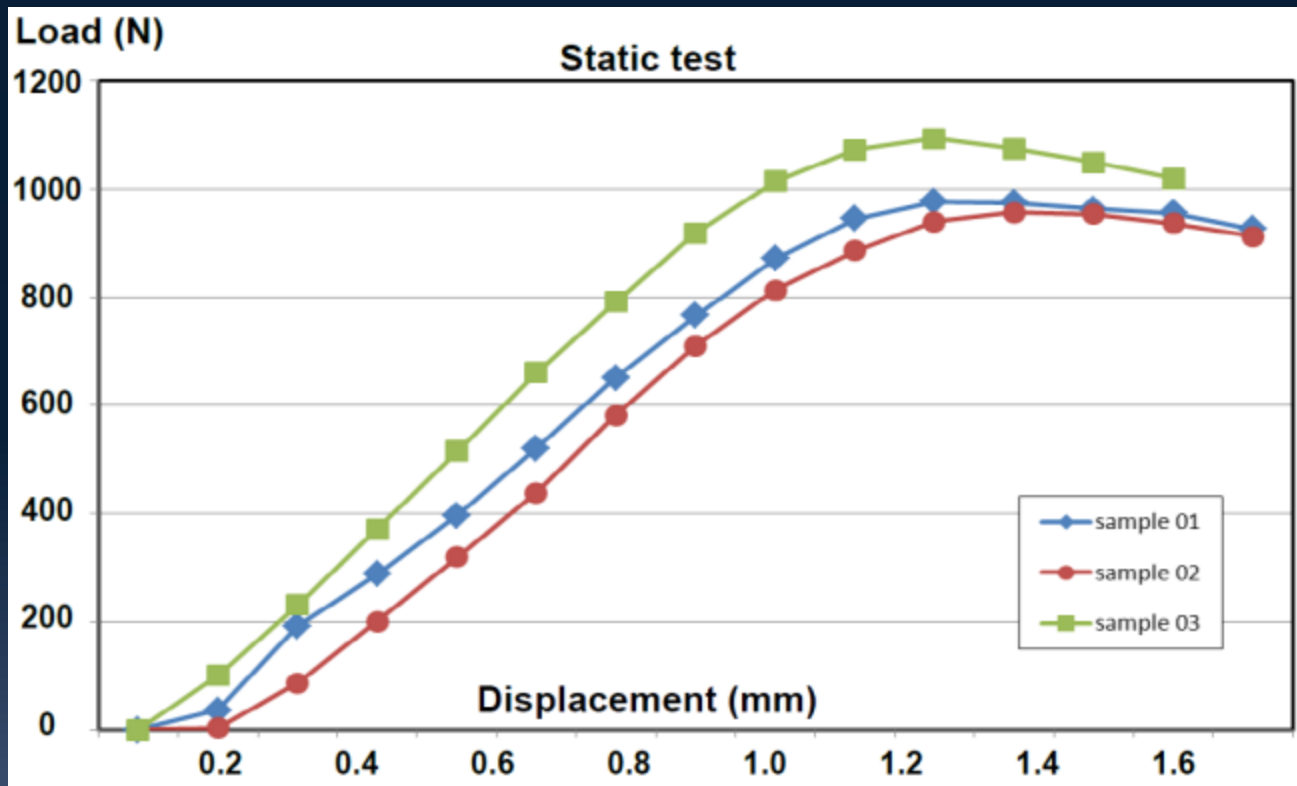

Load-displacement

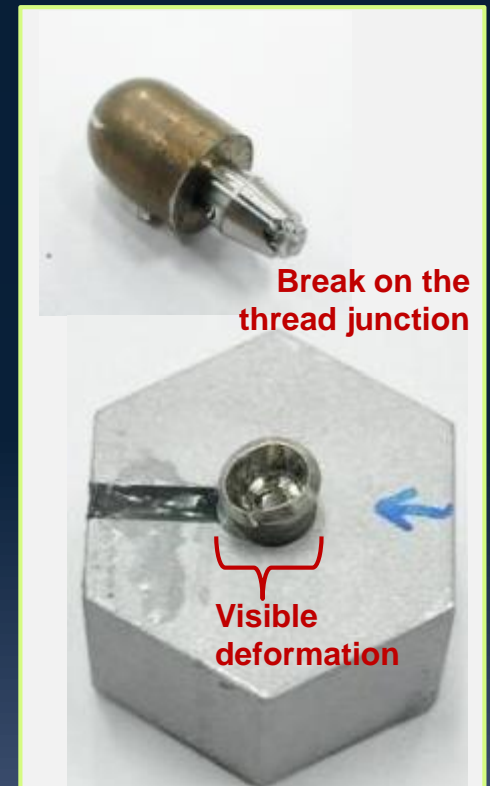

Fracture pattern

Dental Implant Fatigue Test-ISO14801

% of maximum load	Load /(Moment)	Number of cycles	Temp. / HMD.
80%	Between 80.9N to 809N/ (Between 445Nmm to 4450Nmm)	14309	21°C / 71%
		11156	22°C / 70%
		15765	22°C / 70%
70%	Between 70.8N to 708N/ (Between 389Nmm to 3894Nmm)	24446	22°C / 70%
		27809	22°C / 70%
		22065	22°C / 70%
60%	Between 60.7N to 607N/ (Between 334Nmm to 3339Nmm)	91839	26°C / 61%
		112279	26°C / 59%
		92904	28°C / 57%
50%	Between 50.6N to 506N/ (Between 278Nmm to 2783Nmm)	2987597	28°C / 57.5%
		4188494	27°C / 58%
		2062882	24°C / 60.5%
40%	Between 40.5N to 405N/ (Between 223Nmm to 2228Nmm)	5000000 (pass)	25°C / 68%
		5000000 (pass)	21°C / 58%
		5000000 (pass)	25°C / 58%

Dental Implant Fatigue Test-ISO14801

- Fatigue testing
 - Life-time figure

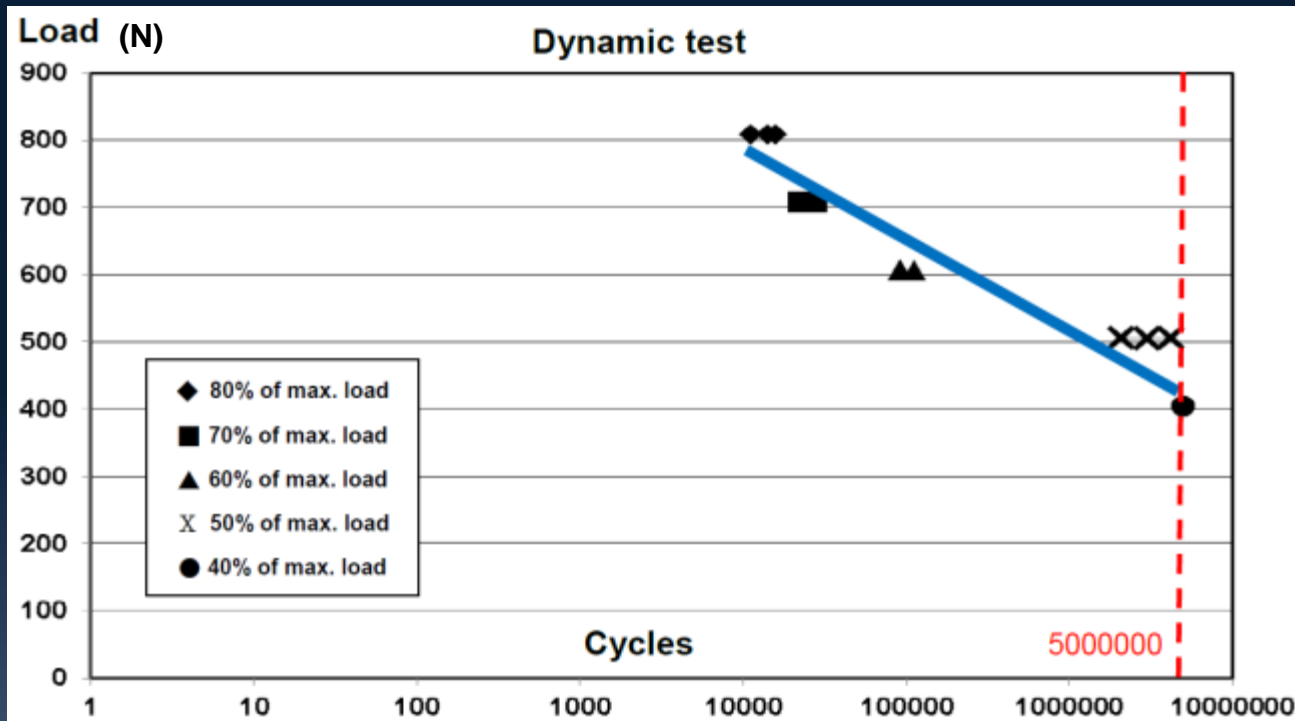

疲勞壽命曲線圖



動態負載後試件

ISO14801—static test (6 cycles)



第一版

Abutment
純鈦

Abutment Screw
純鈦

Fixture
純鈦



第二版

Abutment
鈦合金

Abutment Screw
純鈦

Fixture
純鈦



第三版

Abutment
鈦合金

Abutment Screw
鈦合金

Fixture
純鈦



第四版

1. fixture長度縮短為9mm

第五版

1. 植體外徑由3.45mm增加至3.6mm。
2. 粗細螺紋交接處，增加粗螺紋之內徑(即加工時提早收刀)。

第六版

1. 增加abutment腰身厚度20條。
2. 將abutment/fixture接合向下再深入約1mm (即fixture的morse taper壁側單邊往外擴0.15mm，可將abutment向下移)。

3C/3R (CAD/CAM/CAE, RE/RP/RT)

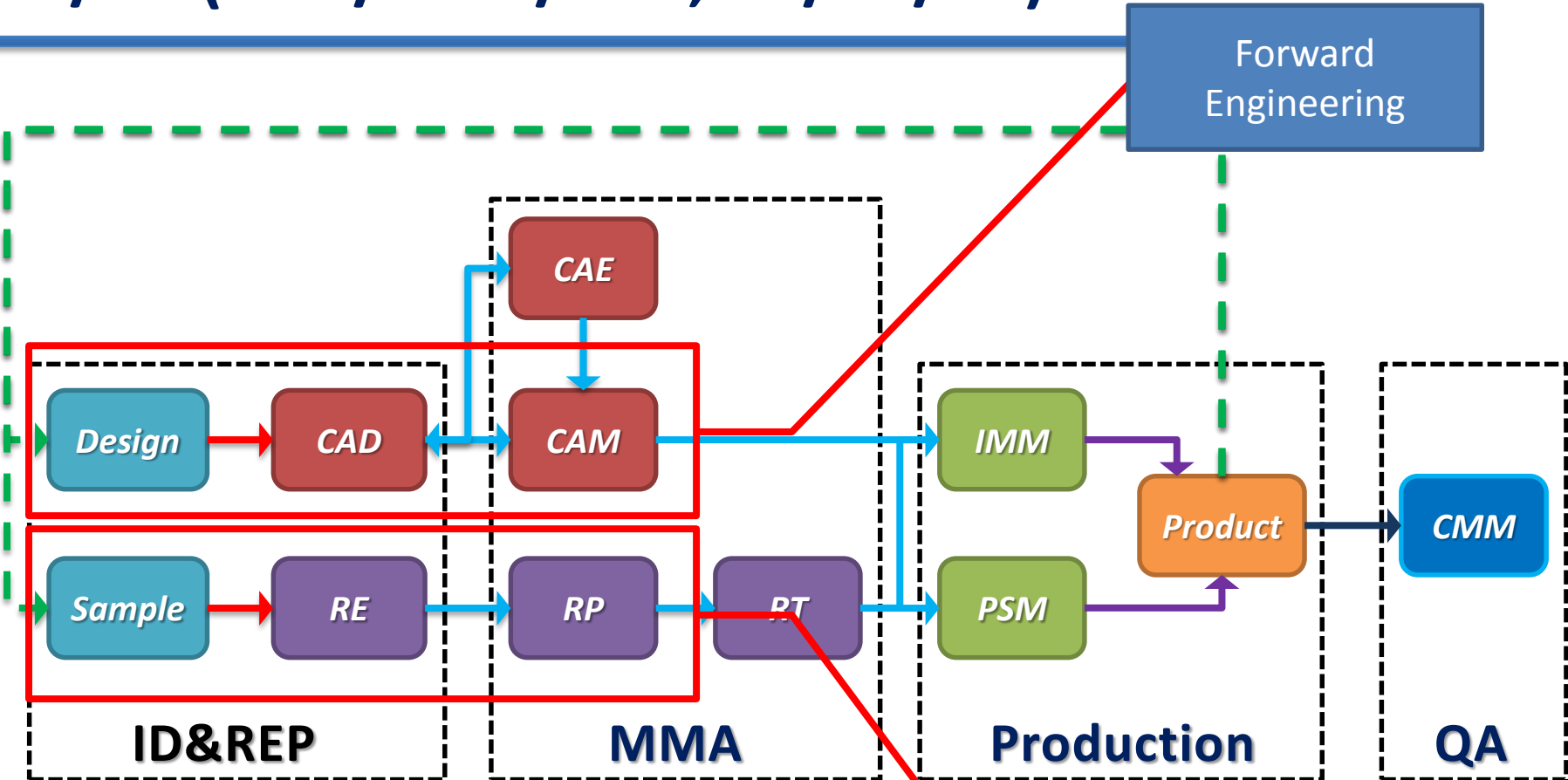

ID : Industrial design

IMM : Injection mould machine

QA : Quality assurance

MMA : Mold manufacturing & analysis

PSM : Pressing/shearing machine

Reverse Engineering

3C/3R (CAD/CAM/CAE, RE/RP/RT)

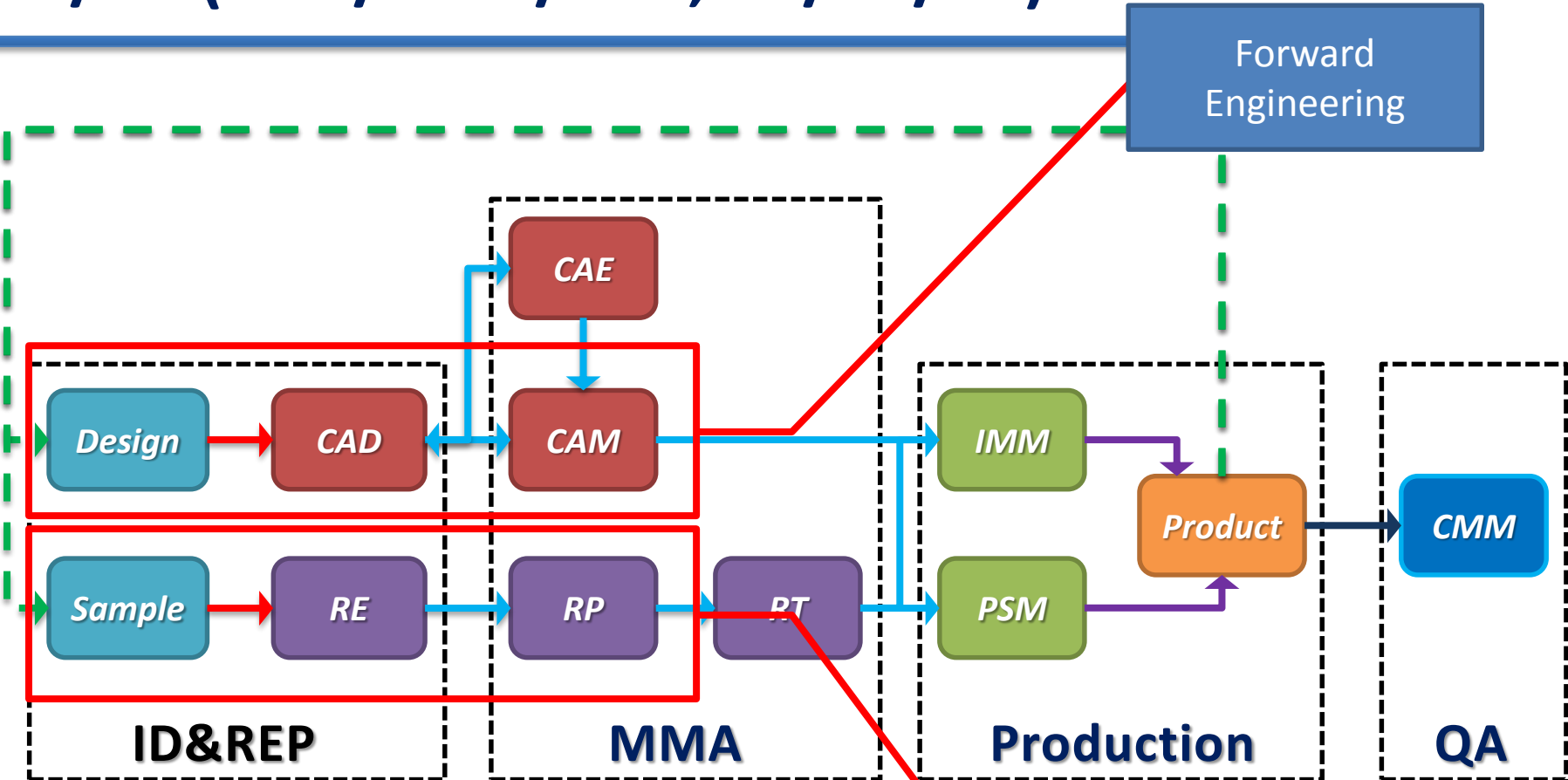

ID : Industrial design

IMM : Injection mould machine

QA : Quality assurance

MMA : Mold manufacturing & analysis

PSM : Pressing/shearing machine

Reverse Engineering



3R

■ Reverse Engineering



3R (RE/RP/RT)

❖ 逆向工程(Reverse Engineering)

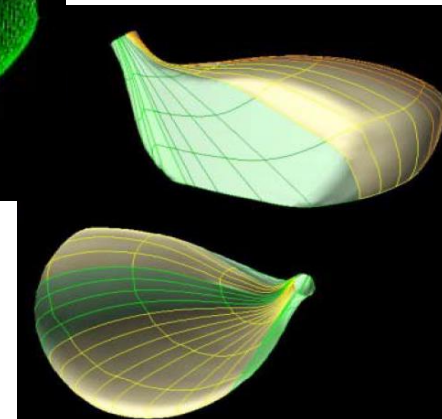
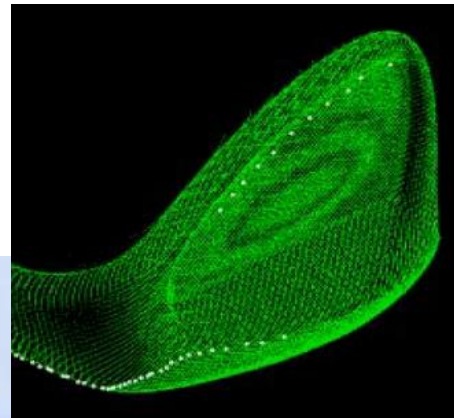
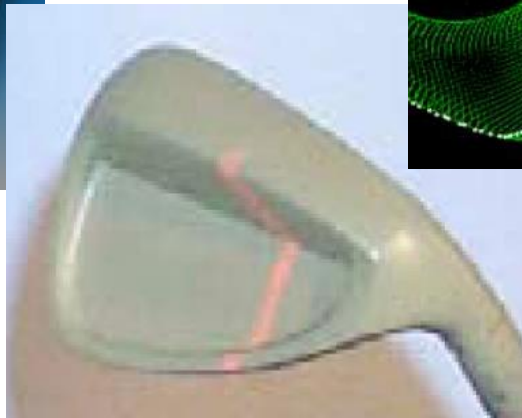
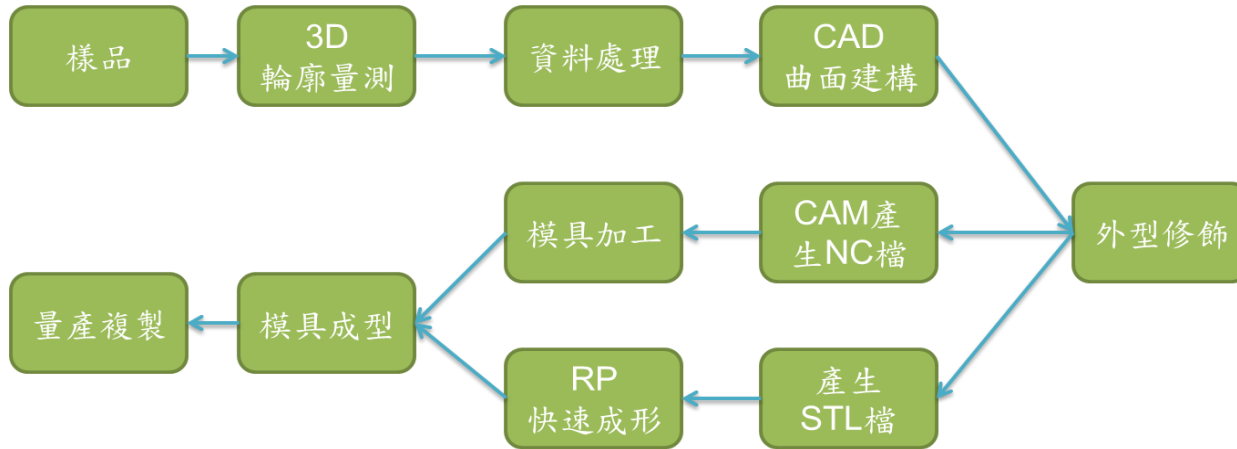

3R (RE/RP/RT)

❖ 逆向工程(Reverse Engineering)

實體樣品

影像掃描
(Laser scanner, CT
etc.)

輪廓擷取
(點、線、面)

影像編修重組



小白齒模型

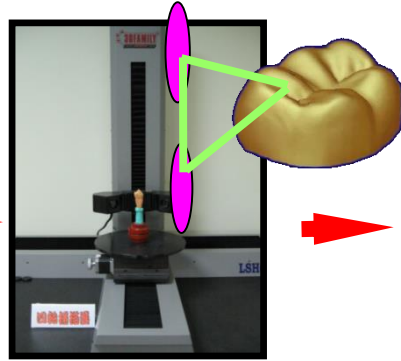

雷射掃描

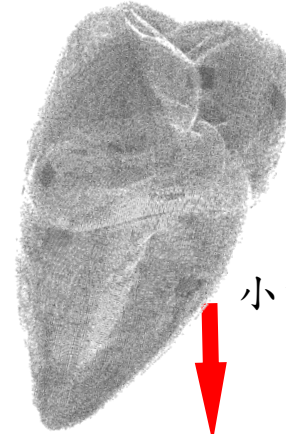

小白齒點資料

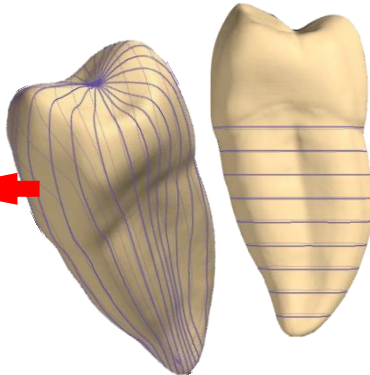
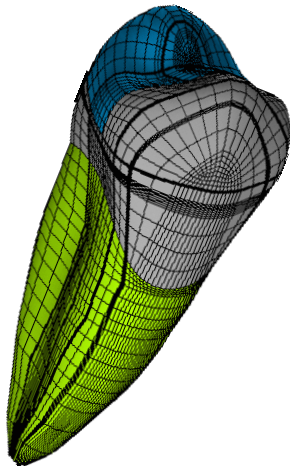

輪廓線截取



三維雕塑機
(FreeForm 繪圖式設計系統)



RE

- **3D geometry/shape measuring**
 - **Laser, CCD, CT, Micro-CT, Dental-CT**

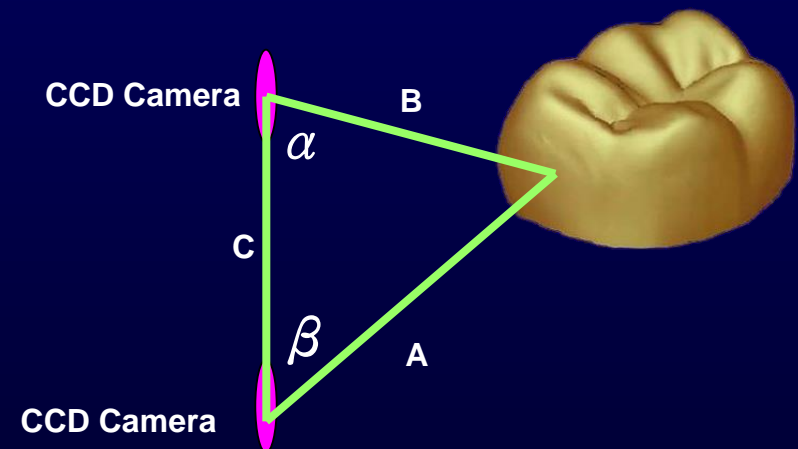

RP build process

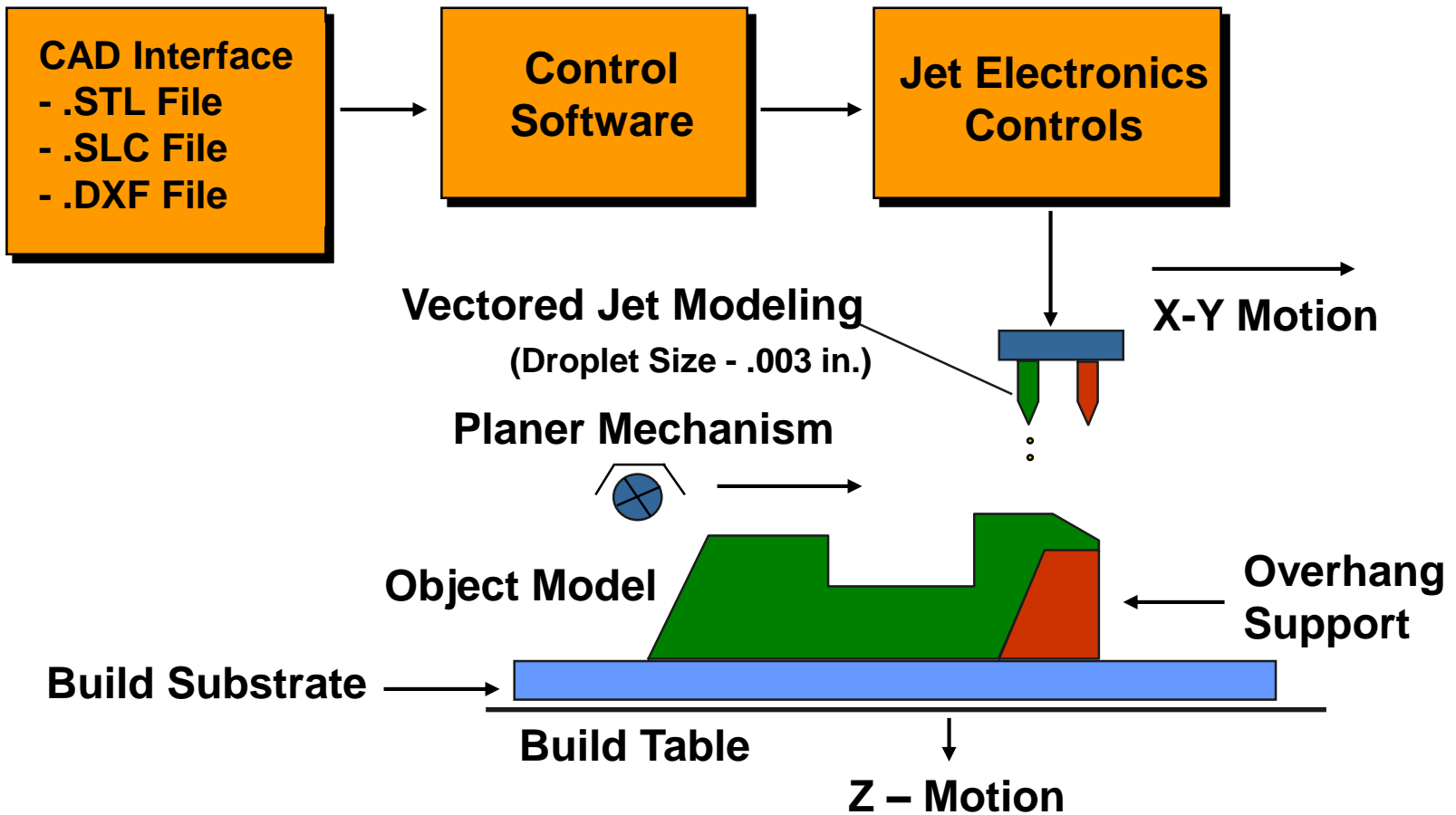

3R (RE/RP/RT)

❖ 快速成形(Rapid prototype)

模型3D設計

轉成.stl檔

產生加工程式

RP快速成形

❖ 快速模具(Rapid Tooling)

原始母型

模具製造設計

灌模

脫模

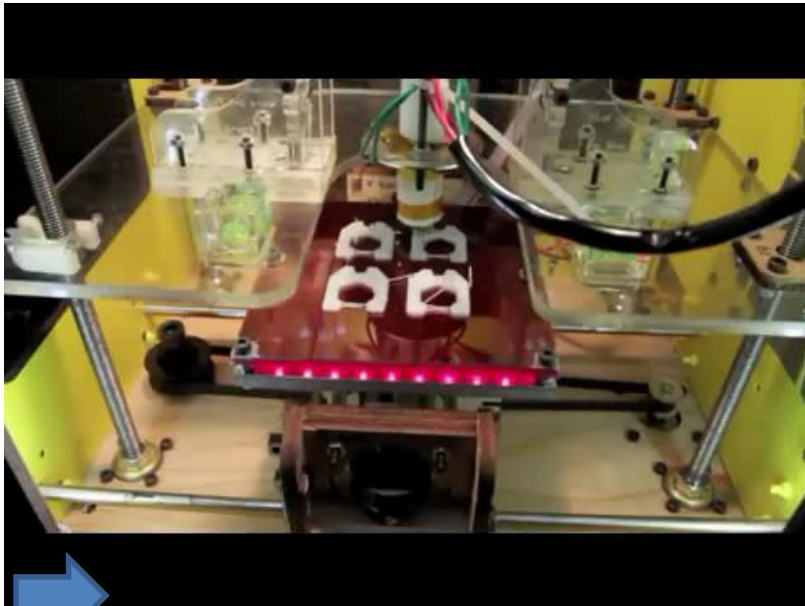

3R (RE/RP/RT) clinical application

❖ 神經外科手術燒灼針三維定位架



腦組織病灶CT影像

CAD機
構設計

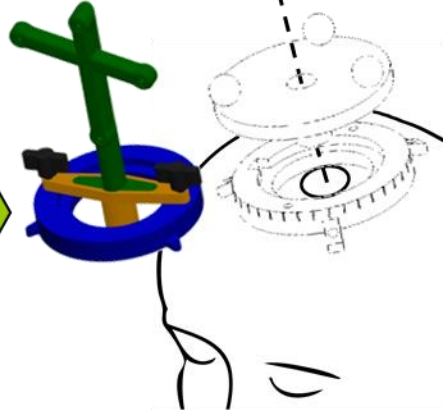

傷口導正對位

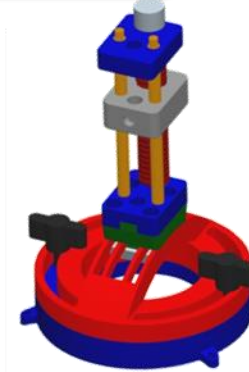
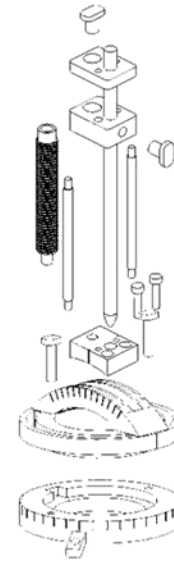

6DOF

燒灼針定位微調侵入

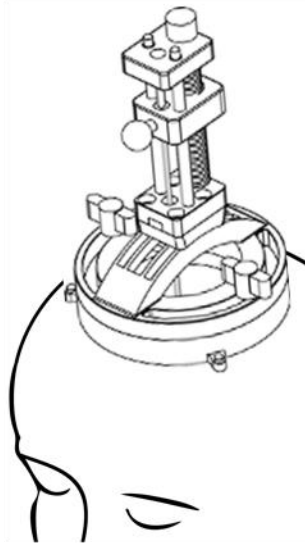

RP

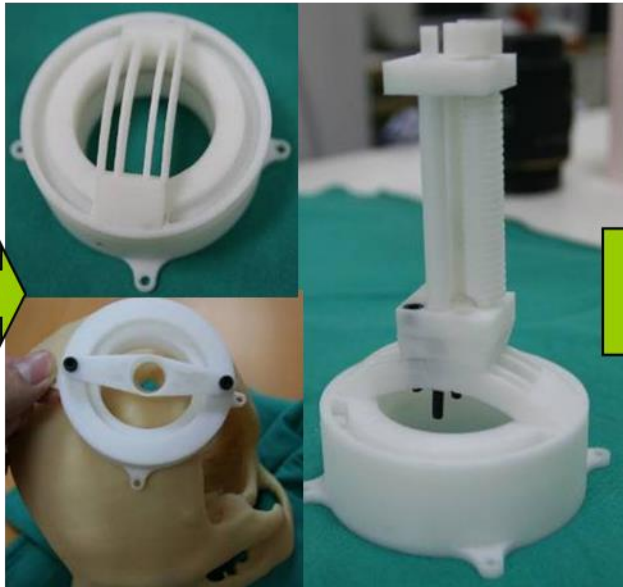

In
vitro
test

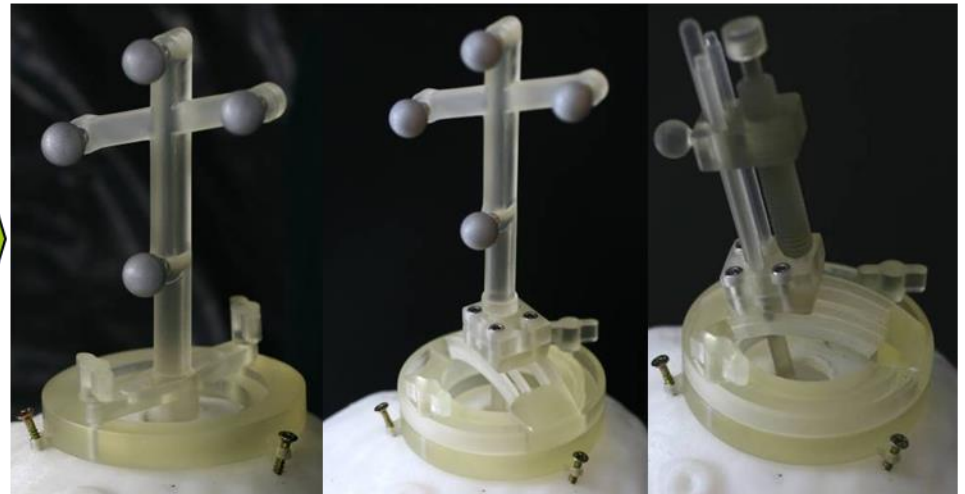

RT silicone molding process



Create Master Pattern

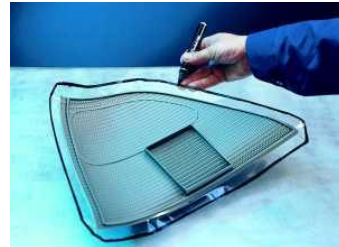

Create Parting Line



Add Gating



Pour Silicone



Vacuum Cast



Split Mold

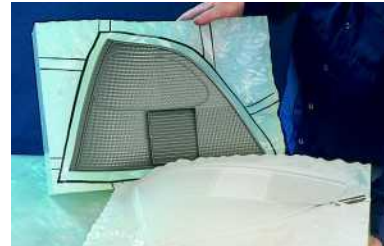

Remove Master Pattern



Close Mold

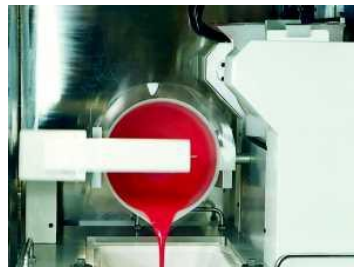

Cast Urathane

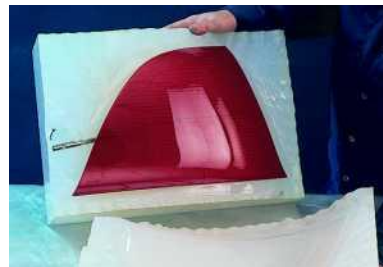

Remove Part



Remove Gating

3R (RE/RP/RT) clinical application

❖ RE/RP/RT之臨床應用



頭顱大範圍缺損

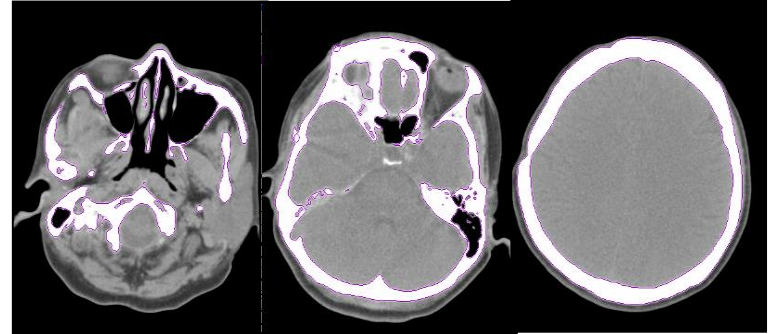

影像處理與重組

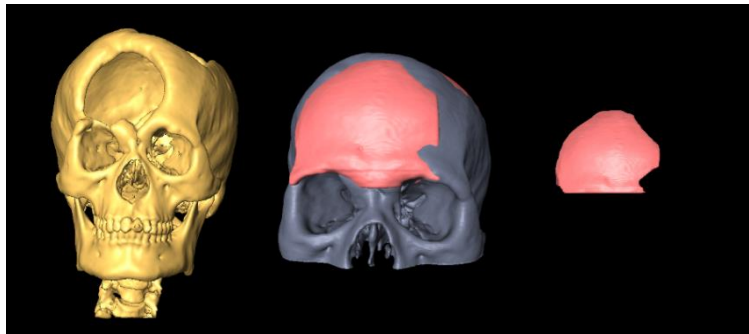

頭顱大範圍缺損補塊影像重建



補塊RP製作



補塊RT製作



臨床應用



案例介紹

■ 逆向工程及快速原型技術於顱骨大範圍缺陷重建

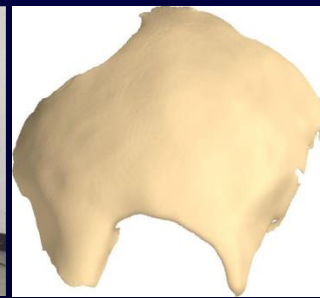
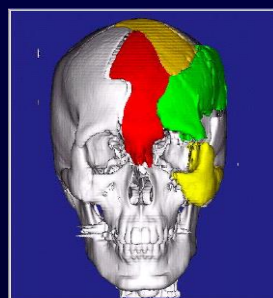
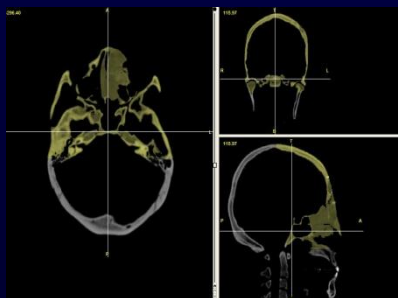
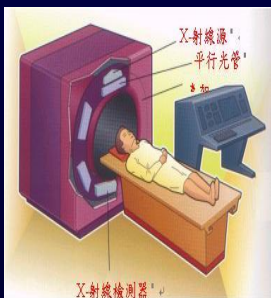

Reverse engineering (RE)

- Amira software

- 3D morphology reconstruction

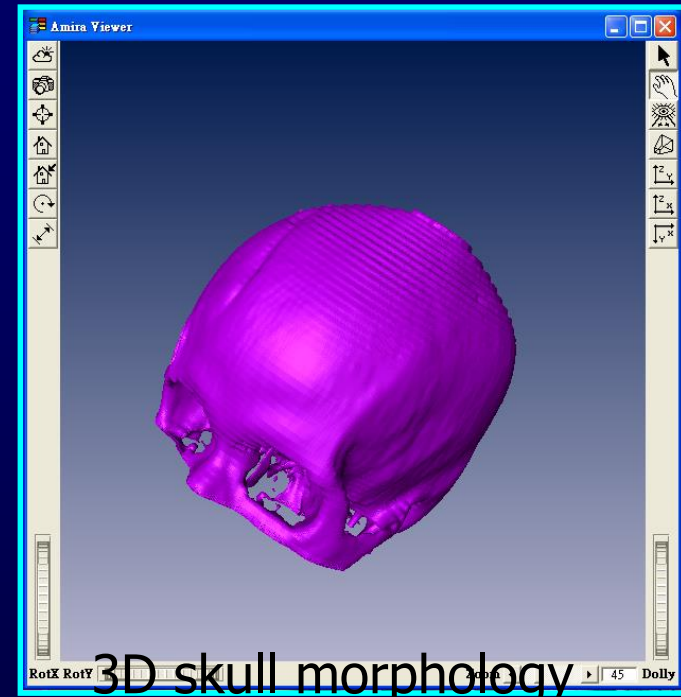
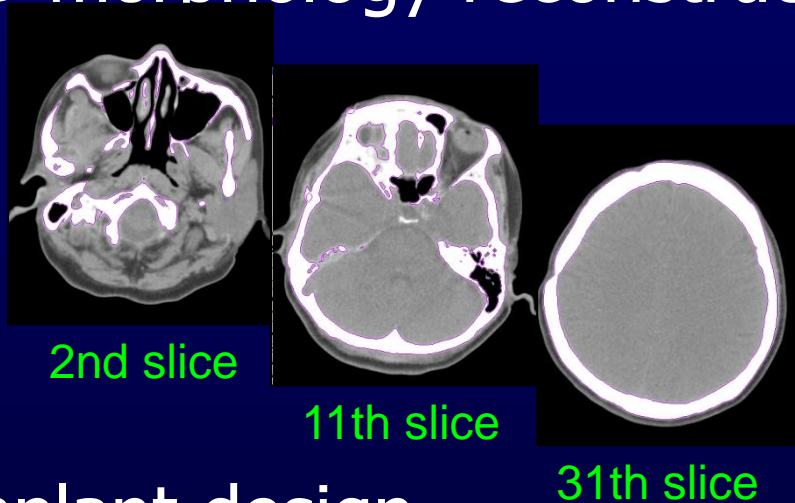

- implant design

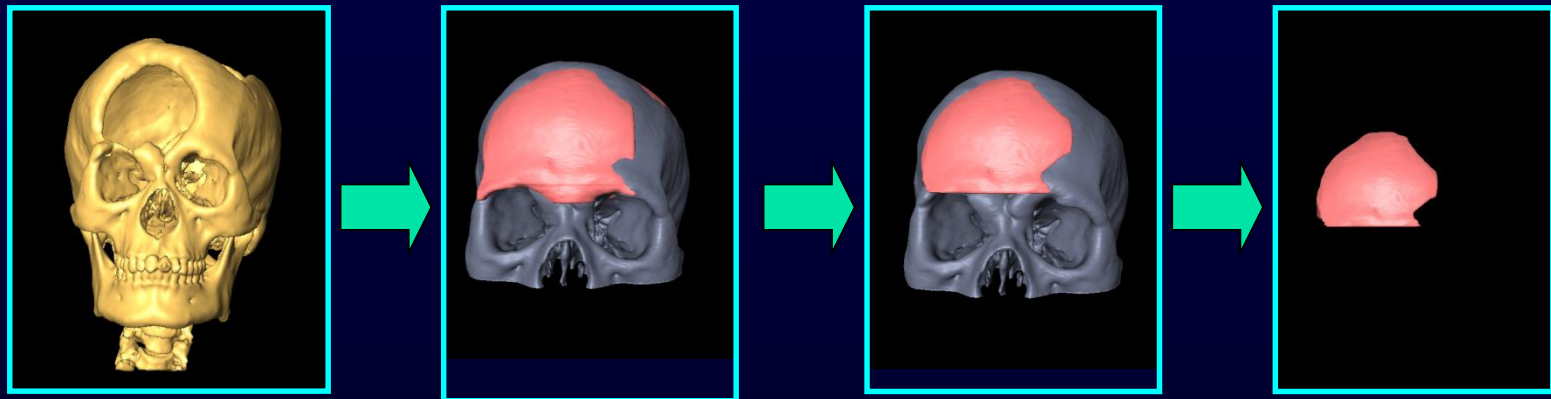

Rapid prototype (RP)

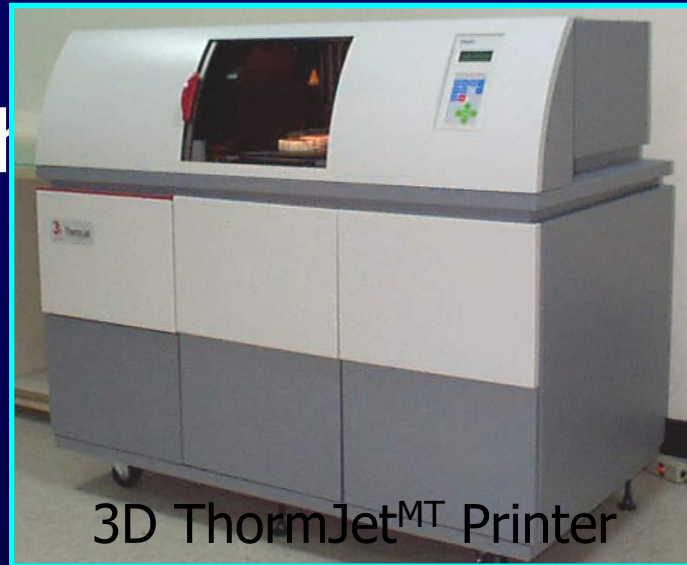

Rapid tooling (RT)

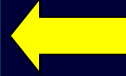

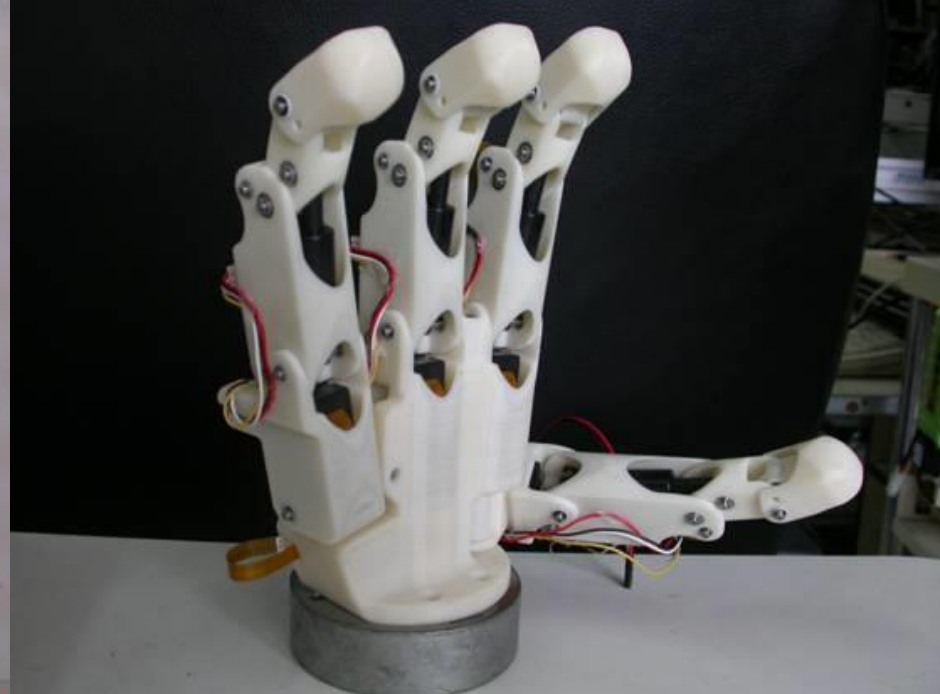

- 機構元件所使用的FDM ABS工程材料，具有高強韌性、耐候不變形的特性，非常適合進行少量生產製作，工件可以當作成品使用。
- 對於設計人員而言，與傳統CNC相比，不需要任何加工經驗與技術，即可再電腦旁快速輸出各種機構設計元件，不受加工程序限制。
- 大幅縮短設計變更時間，上午設計變更完成，下午就能進行測試。

元智大學機械系陳傳生教授